

G - TESTS W/CODES

Article Text

1992 Dodge Colt

For a a a a

Copyright © 1998 Mitchell Repair Information Company, LLC
Saturday, April 27, 2002 05:49PM

ARTICLE BEGINNING

1992 ENGINE PERFORMANCE
Chrysler Motors Self-Diagnostics

Dodge; Colt
Eagle; Summit
Plymouth; Colt

INTRODUCTION

If no faults were found while performing F - BASIC TESTING, proceed with self-diagnostics. If no fault codes or only pass codes are present after entering self-diagnostics, proceed to H - TESTS W/O CODES article in the ENGINE PERFORMANCE Section for diagnosis by symptom (i.e., ROUGH IDLE, NO START, etc.).

SELF-DIAGNOSTIC SYSTEM

SYSTEM DIAGNOSIS

Use Chrysler Motors code charts when using Chrysler's Diagnostic Readout Box (DRB-II). If DRB-II is not available, system diagnosis can be accomplished using a voltmeter. To perform self-diagnostics using a voltmeter, see RETRIEVING CODES (USING VOLTMETER).

NOTE: Chrysler Motors recommends using DRB-II to diagnose system. Voltmeter usage has limited diagnostic capabilities, but can be used if DRB-II is not available.

Engine Control Unit (ECU) monitors several different engine control system circuits. If an abnormal input signal occurs, a fault code is stored in ECU memory and given a fault code number. Each circuit has its own fault number and message. A fault code does not condemn any specific component; it simply points out a probable malfunctioning area.

Fault codes can be confirmed by using a voltmeter or Chrysler's Diagnostic Readout Box (DRB-II). See RETRIEVING CODES (USING VOLTMETER) or RETRIEVING CODES (USING DRB-II). By using DRB-II, self-diagnostic capabilities of this system can simplify testing and reduce diagnostic time.

System malfunctions encountered are identified as either hard failures or intermittent failures as determined by ECU.

Hard Failures

Hard failures cause CHECK ENGINE light to illuminate and remain on until malfunction is repaired. If light comes on and remains on (light may flash) during vehicle operation, cause of malfunction must be determined by using FAULT CODES table (if testing with voltmeter) or diagnostic CODE CHARTS (if testing with DRB-II). If a sensor fails, ECU will use a substitute value in its calculations to

G - TESTS W/CODES

Article Text (p. 2)

1992 Dodge Colt

For a a a a

Copyright © 1998 Mitchell Repair Information Company, LLC

Saturday, April 27, 2002 05:49PM

continue engine operation. In this condition, vehicle is functional, but loss of good driveability may result.

Intermittent Failures

Intermittent failures may cause CHECK ENGINE light to flicker or illuminate and go out after intermittent fault goes away. However, corresponding trouble code will be retained in ECU memory. If related fault does not reoccur within a certain time frame, related trouble code will be erased from ECU memory. Intermittent failures may be caused by a sensor, connector or wiring related problems. See INTERMITTENTS in H - TESTS W/O CODES article in the ENGINE PERFORMANCE Section.

PRETEST INSPECTION

Before proceeding with diagnosis, following precautions must be observed:

- * Vehicle must have a fully charged battery and functional charging system.
- * Visually inspect connectors and circuit wiring being worked on.
- * DO NOT disconnect battery or ECU. This will erase any fault codes stored in ECU.
- * DO NOT cause short circuits when performing electrical tests. This will set additional fault codes, making diagnosis of original problem more difficult.
- * DO NOT use a test light in place of a voltmeter.
- * When checking for spark, ensure coil wire is NOT more than 1/4" from ground. If coil wire is more than 1/4" from ground, damage to vehicle electronics and/or ECU may result.
- * DO NOT prolong testing of fuel injectors. Engine may hydrostatically (liquid) lock.
- * When a vehicle has multiple fault codes, always repair lowest number fault code first.
- * If using DRB-II to diagnose system, always perform verification test after repairs are made.

RETRIEVING CODES (USING VOLTMETER)

1) Before entering on-board diagnostics, see PRETEST INSPECTION. Turn ignition switch to OFF position. Locate self-diagnostic connector, which is next to fuse block. Using an analog voltmeter, connect volt-meter positive lead to self-diagnostic connector terminal No. 1 (output) and negative lead to terminal No. 12 (ground). See Fig. 1.

2) Turn ignition switch to ON position and disclosure of ECU memory will begin. If 2 or more systems are non-functional, they are indicated by order of increasing code number. Indication is made by 12-volt pulses of voltmeter pointer. A constant repetition of short 12-volt pulses indicates system is normal. If system is abnormal, voltmeter will pulse between zero and 12 volts.

G - TESTS W/CODES

Article Text (p. 3)

1992 Dodge Colt

For a a a a

Copyright © 1998 Mitchell Repair Information Company, LLC

Saturday, April 27, 2002 05:49PM

3) Signals will appear on voltmeter as long and short 12-volt pulses. Long pulses represent tens; short pulses represent ones. For example, 4 long pulses and 3 short pulses indicate Code 43. After recording abnormal code(s), perform necessary repair. See FAULT CODES.

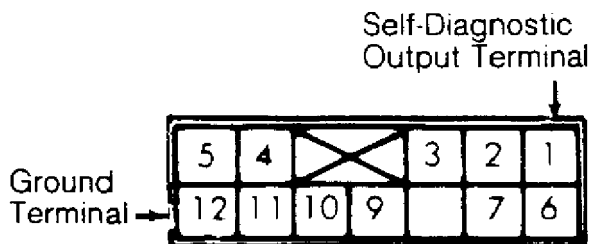

92C25959

Fig. 1: Self-Diagnostic Connector Terminal ID
Courtesy of Chrysler Motors.

DIAGNOSTIC PROCEDURE (USING DRB-II)

NOTE: When using diagnostic code charts, DO NOT skip any steps in chart or incorrect diagnosis may result. Always check related Technical Service Bulletins (TSBs).

Refer to RETRIEVING CODES (USING DRB-II) to retrieve fault codes. If fault codes are NOT present and DRB-II is used, proceed to one of the following tests:

- * Go to NO START TEST 1 (NS-1) chart if a no-start condition exists or engine stalls after start-up. Perform indicated VERIFICATION PROCEDURE chart (when provided) after repairs. Ensure charts apply to engine being tested.
- * Go to DRIVEABILITY TEST 1 (DR-1) chart if engine runs but has performance problems. Perform indicated VERIFICATION TEST chart (when provided) after repairs. Ensure charts apply to engine being tested.

DRB-II KEY FUNCTIONS

YES Or Down Arrow & NO Or Up Arrow

Keys will move lines on screen up or down, allowing user to choose an item or scroll through all selections available.

F1 & F2 Keys

Keys are used to scroll through sensor displays.

ATM Key

Key will return user to previous screen.

ENTER Key

Allows user to select a test or display. Flashing arrow must be on display user wishes to select. Pressing ENTER in sensor state will cause display to change from a 3-line display to a 1-line display.

G - TESTS W/CODES

Article Text (p. 4)

1992 Dodge Colt

For a a a a

Copyright © 1998 Mitchell Repair Information Company, LLC

Saturday, April 27, 2002 05:49PM

F3 Key

Key is used to display a help screen. This key may be used at any time.

Number Keys

Keys are used for choosing a display or test by number for test or display.

READ/HOLD Key

Key is used to freeze any sensor display.

MODE & ATM Keys

Pressing MODE and ATM keys at same time will cause DRB-II to reset to copyright screen.

RETRIEVING CODES (USING DRB-II)

1) Before entering on-board diagnostics, see PRETEST INSPECTION. Turn ignition off. Locate self-diagnostic connector, which is next to fuse block. Using appropriate Mitsubishi cartridge and adapter, connect DRB-II to diagnostic connector.

2) Ensure all accessories are off. Turn ignition on. All character positions will illuminate and copyright information will appear on screen for a few seconds.

3) If DRB-II screen displays an error message, see DRB-II ERROR SCREENS. DRB-II will offer 4 menus: VEHICLES TESTED, HOW TO USE, CONFIGURE and SELECT VEHICLE.

VEHICLES TESTED

Press "1" key or ENTER key when VEHICLES TESTED appears on DRB-II. DRB-II shows models covered by cartridge. Screen will display for 5 seconds and return to DRB-II menu. To return to DRB-II menu sooner, press ATM key.

HOW TO USE

Press "2" key or press down arrow to display HOW TO USE option and press ENTER. Press and hold F3 key. DRB-II displays instructions for cartridge usage. To return to DRB-II menu, press ATM key.

CONFIGURE

Press "3" key or press down arrow to display CONFIGURE option, and press ENTER. CONFIGURE allows user to customize DRB-II display. For example, if metric system is more useful, select METRIC from menu. All selections in CONFIGURE option remain active until user changes selection.

SELECT VEHICLE

1) This allows user to enter information about vehicle being tested. Usually, this option has more than one display screen. Use ENTER key to enter vehicle information.

G - TESTS W/CODES

Article Text (p. 5)

1992 Dodge Colt

For a a a a

Copyright © 1998 Mitchell Repair Information Company, LLC

Saturday, April 27, 2002 05:49PM

2) When all information about vehicle is entered, DRB-II will display an information summary technician has entered. DRB-II will show an additional option marked CONFIRM. If information is correct, press CONFIRM. DRB-II will display MAIN MENU.

MAIN MENU

MAIN MENU represents all diagnostic functions available. Functions are SYSTEM TESTS, READ FAULTS, STATE DISPLAYS, ACTUATOR TESTS and ADJUSTMENTS. SYSTEM TESTS is NOT available.

READ FAULTS

This allows technician to read fault codes stored in ECU memory.

STATE DISPLAYS

1) This allows technician to view conditions at signal level. The 2 types of signals are analog and digital. Analog signals are monitored at pins corresponding to vehicle harness splices (e.g., fuel pump relay).

2) Digital signals correspond to data transmitted by system controllers. Both signals are displayed in common units (e.g., temperature). Use up and down arrow keys on DRB-II to scroll through displays available.

3) Following ENGINE state displays are available on DRB-II:

- * Module Information

This mode allows technician to read ECU part number and application.

- * Engine Sensors

This mode allows technician to look at various engine sensors during engine operation.

- * Inputs/Outputs

This mode allows technician to read input and output states of various switches and sensors.

- * Custom Display

This screen allows technician to set up his/her own custom display. Two custom display screens can be programmed into DRB-II.

- * Minimum/Current/Maximum

MIN/CURRENT/MAX display shows a history of conditions for a specific sensor. When this option is selected, maximum, current (static) and minimum values can be displayed for a specific sensor. To reset sensors to a zero value, simply press ENTER key. This display may be used to isolate intermittent faults. MIN/CURRENT/MAX display allows technician to observe operation of 6 different sensor values. Information is displayed as a 3-digit number. First value displayed is the minimum reading, second number is current reading and third value is the maximum reading. Typically sensors range between 2 and 252. Values less than 2 or greater than 252 will usually indicate that a sensor is shorted or disconnected. Watch minimum and maximum values to

G - TESTS W/CODES

Article Text (p. 6)

1992 Dodge Colt

For a a a a

Copyright © 1998 Mitchell Repair Information Company, LLC

Saturday, April 27, 2002 05:49PM

help diagnose intermittent problems.

* Monitors

This screen shows technician sensors and system controllers which affect fuel control, spark advance, RPM and A/C relay. There are 4 different screens available. For example, screen No. 1 will show: airflow sensor, O2 sensor, battery and fuel injector. All of these inputs affect fuel control.

Actuator Tests

This mode allows technician to actuate injectors, fuel pump, purge control, EGR solenoid, fuel pressure solenoid and wastegate.

Adjustments

This option provides a means for erasing fault code information stored in ECU. Follow DRB-II instructions to accomplish this task.

DRB-II ERROR SCREENS

SYSTEM FAULT ROM CHECK SUM XXXX Message
Cartridge or DRB-II failure.

SYSTEM FAULT KEYBOARD FAILURE Message
Restart DRB-II. Ensure DRB-II keys are not pressed during power up. Another possibility is DRB-II failure.

SYSTEM FAULT ROM FAILURE XXXX Message
DRB-II failure.

SYSTEM FAULT EEPROM FAILURE Message
DRB-II failure.

SYSTEM FAILURE, COMMUNICATION FAILURE, REFER TO DIAGNOSTIC PROCEDURES Message
On 1.5L, 2.4L and 3.0L Ram-50, perform diagnostic connector test. See DRIVEABILITY TEST No. 8 (DR-8). On Stealth, perform appropriate TEST DRB-1. On all models, failure of Mitsubishi Motor Corporation (MMC) adapter is another possibility.

SYSTEM FAILURE NO RESPONSE FROM ADAPTER or SYSTEM FAILURE ADAPTER REQUIRED TO DIAGNOSE WITH THIS CARTRIDGE Message
Ensure you are using a correct Mitsubishi Motor Corporation cartridge. Failure of MMC adapter is another possibility.

FAULT CODES

NOTE: Codes listed in FAULT CODES table are not used on all vehicles.

FAULT CODES TABLE

Code	Component	(1) Possible Cause
------	-----------	--------------------

G - TESTS W/CODES

Article Text (p. 7)

1992 Dodge Colt

For a a a a

Copyright © 1998 Mitchell Repair Information Company, LLC

Saturday, April 27, 2002 05:49PM

(2)	Engine Control Unit	Engine Control Unit
11	Oxygen Sensor (3)	Harness & Connector, Oxygen Sensor, Fuel Pressure, Injectors, Intake Air Leaks
12	Airflow Sensor	Harness & Connector, Airflow Meter
13	Intake Air Temperature Sensor	Harness & Connector, Intake Air Temperature Sensor
14	Throttle Position Sensor	Harness & Connector, Throttle Position Sensor, Idle Position Switch
15	Motor Position Sensor	Harness & Connector, Motor Position Sensor, Throttle Position Sensor
21	Coolant Temperature Sensor	Harness & Connector, Coolant Temperature Sensor
22	Crank Angle Sensor	Harness & Connector, Distributor Assembly
23	Top Dead Center Sensor	Harness & Connector, Crank Angle Sensor
24	Vehicle Speed Sensor	Harness & Connector, Vehicle Speed Sensor
25	Barometric Pressure Sensor	Harness & Connector, Barometric Pressure Sensor
31	Detonation Sensor (4)	Harness & Connector, Detonation Sensor
36	Ignition Timing Adjustment Signal	Harness & Connector
39	Oxygen Sensor (5)	Harness & Connector, Oxygen Sensor, Fuel Pressure, Injectors, Air Intake Leaks
41	Injector	Harness & Connector, Injector Coil Resistance
42	Fuel Pump	Harness & Connector, Control Relay

G - TESTS W/CODES

Article Text (p. 8)

1992 Dodge Colt

For a a a a

Copyright © 1998 Mitchell Repair Information Company, LLC

Saturday, April 27, 2002 05:49PM

43	EGR (6)	Harness & Connector, EGR Temperature Sensor, EGR Valve, EGR Control Solenoid, EGR Valve Control Vacuum
44	Ign. Coil & Power Transistor (Cyl. No. 1 & 4) (4)	Harness & Connector, Ignition Coil, Power Transistor
52	Ign. Coil & Power Transistor (Cyl. No. 2 & 5) (4)	Harness & Connector, Ignition Coil, Power Transistor
53	Ign. Coil & Power Transistor (Cyl. No. 3 & 6) (4)	Harness & Connector, Ignition Coil, Power Transistor
61	Torque Reduction Signal Low (4) (7)	Harness & Connector, Transaxle Control Unit
62	Induction Control Valve Position Sensor (8)	Harness & Connector, Induction Control Valve Position Sensor, Air Intake Plenum Assembly

- (1) - Replace ECU if inspection of possible cause items reveals no problem.
- (2) - CHECK ENGINE Light Stays On
- (3) - Applies to non-turbo models and rear cylinders on Stealth turbo.
- (4) - Dual Overhead Cam (DOHC) models.
- (5) - Oxygen sensor for front cylinders on Stealth turbo.
- (6) - California only.
- (7) - Automatic transaxle only.
- (8) - Non-turbo only.

CLEARING CODES

Using DRB-II, from main menu select ADJUSTMENTS. Enter ERASE FAULTS. Follow DRB-II instructions to accomplish this task. If DRB-II is not available, fault codes may be cleared by disconnecting negative battery cable for at least 10 seconds, allowing ECU to clear fault codes.

ECU LOCATION

ECU LOCATION TABLE

Application	Location
All Models	Behind Right Side Of Instrument Panel, Next To Blower Motor

G - TESTS W/CODES

Article Text (p. 9)

1992 Dodge Colt

For a a a a

Copyright © 1998 Mitchell Repair Information Company, LLC
Saturday, April 27, 2002 05:49PM

CONNECTOR IDENTIFICATION

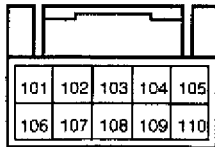

10-WAY CONNECTOR

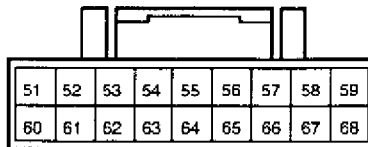

18-WAY CONNECTOR

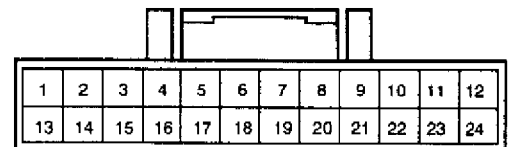

24-WAY CONNECTOR

NOTE: ECU CONNECTOR ILLUSTRATIONS ARE NOT AVAILABLE FOR MONTERO 3.0L,
PRECIS 1.5L & SIGMA 3.0L. SEE WIRING DIAGRAMS ARTICLE.

Fig. 2: ECU 10-Way Connector Terminal ID
Courtesy of Chrysler Motors.

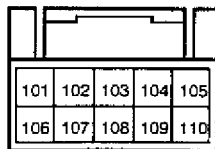

10-WAY CONNECTOR

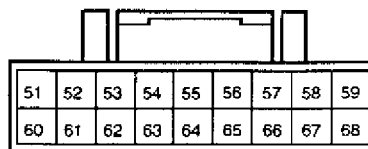

18-WAY CONNECTOR

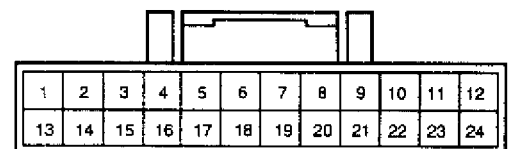

24-WAY CONNECTOR

NOTE: ECU CONNECTOR ILLUSTRATIONS ARE NOT AVAILABLE FOR MONTERO 3.0L,
PRECIS 1.5L & SIGMA 3.0L. SEE WIRING DIAGRAMS ARTICLE.

Fig. 3: ECU 18-Way Connector Terminal ID
Courtesy of Chrysler Motors.

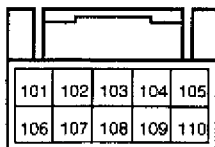

10-WAY CONNECTOR

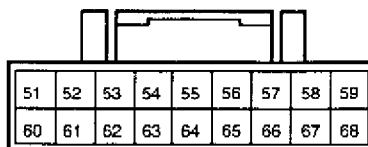

18-WAY CONNECTOR

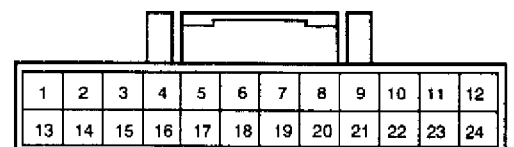

24-WAY CONNECTOR

NOTE: ECU CONNECTOR ILLUSTRATIONS ARE NOT AVAILABLE FOR MONTERO 3.0L,
PRECIS 1.5L & SIGMA 3.0L. SEE WIRING DIAGRAMS ARTICLE.

Fig. 4: ECU 24-Way Connector Terminal ID
Courtesy of Chrysler Motors.

CODE CHARTS

NOTE: Following trouble shooting charts and illustrations are courtesy of Chrysler Motors. To identify ECU connector terminals, see CONNECTOR IDENTIFICATION.

NS-1: IGNITION CHECK

G - TESTS W/CODES

Article Text (p. 10)

1992 Dodge Colt

For a a a a

Copyright © 1998 Mitchell Repair Information Company, LLC

Saturday, April 27, 2002 05:49PM

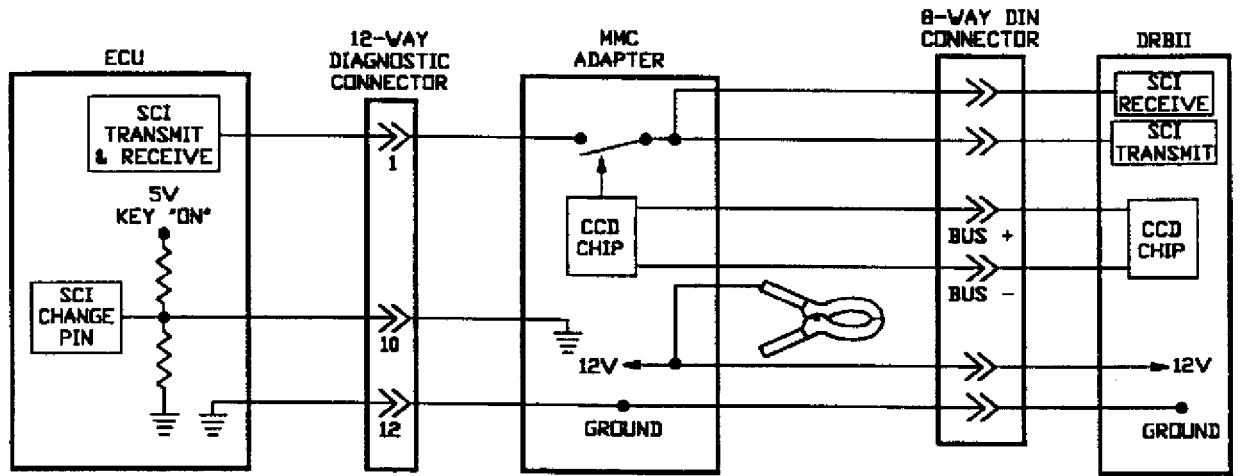

Fig. 5: No Start Test 1 Schematic (1 Of 3)
Ignition Check

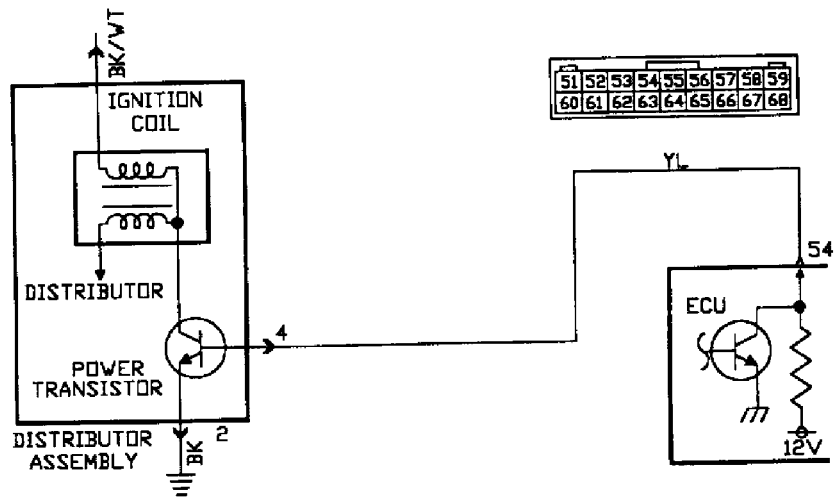

Fig. 6: No Start Test 1 Schematic (2 Of 3)
Ignition Check

G - TESTS W/CODES

Article Text (p. 11)

1992 Dodge Colt

For a a a a

Copyright © 1998 Mitchell Repair Information Company, LLC

Saturday, April 27, 2002 05:49PM

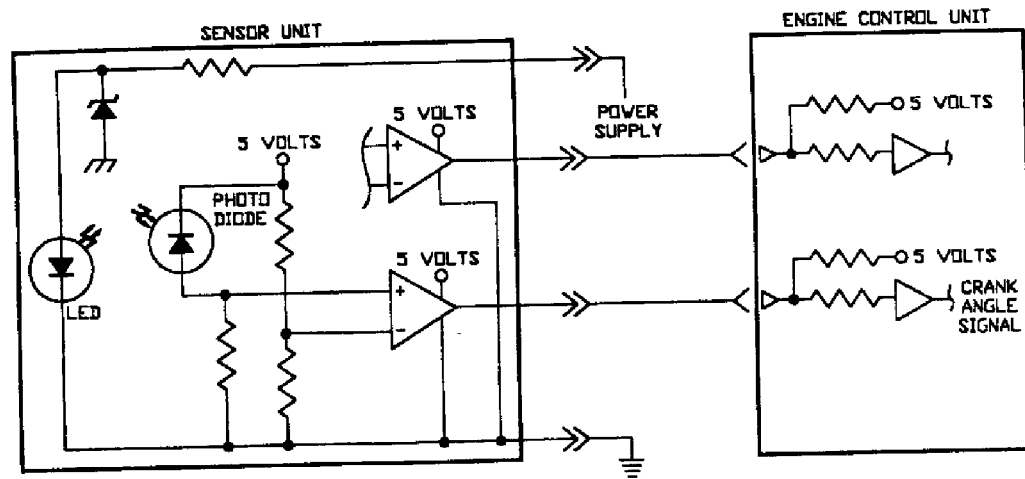

Fig. 7: No Start Test 1 Schematic (3 Of 3)
Ignition Check

G - TESTS W/CODES

Article Text (p. 12)

1992 Dodge Colt

For a a a a

Copyright © 1998 Mitchell Repair Information Company, LLC

Saturday, April 27, 2002 05:49PM

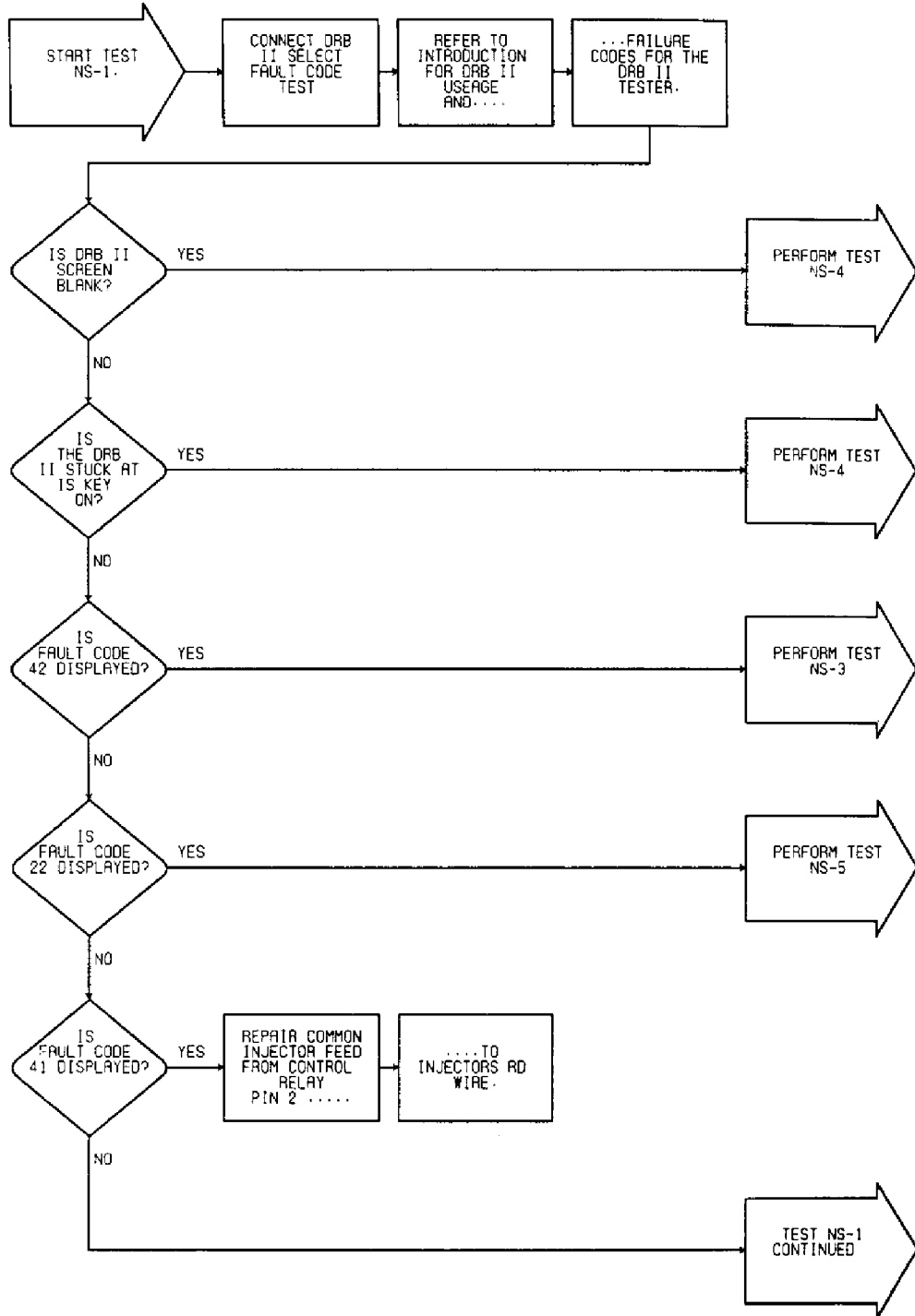

Fig. 8: No Start Test 1 Flow Chart (1 Of 5)
Ignition Check

G - TESTS W/CODES

Article Text (p. 13)

1992 Dodge Colt

For a a a a

Copyright © 1998 Mitchell Repair Information Company, LLC

Saturday, April 27, 2002 05:49PM

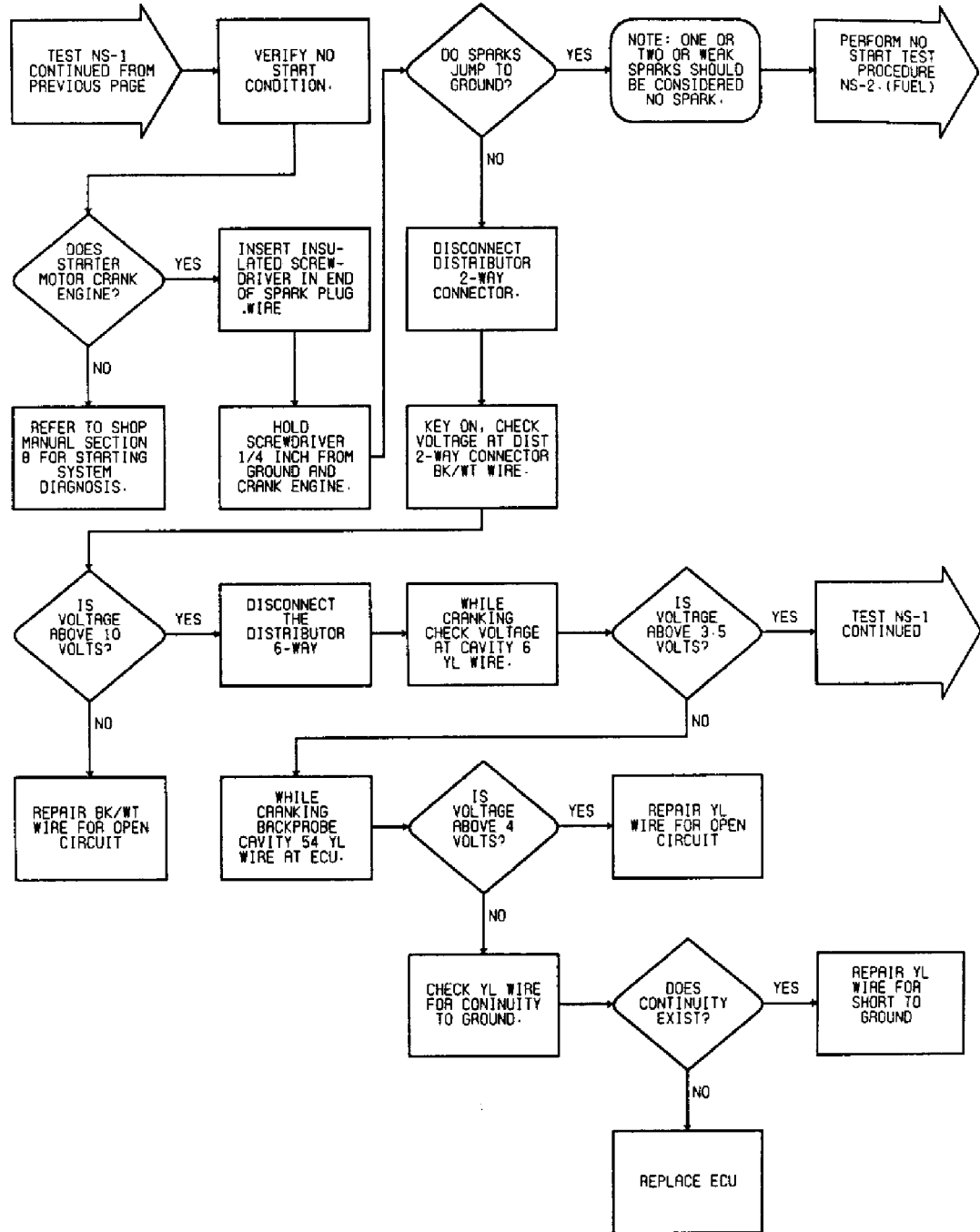

Fig. 9: No Start Test 1 Flow Chart (2 Of 5)
Ignition Check

G - TESTS W/CODES

Article Text (p. 14)

1992 Dodge Colt

For a a a a

Copyright © 1998 Mitchell Repair Information Company, LLC

Saturday, April 27, 2002 05:49PM

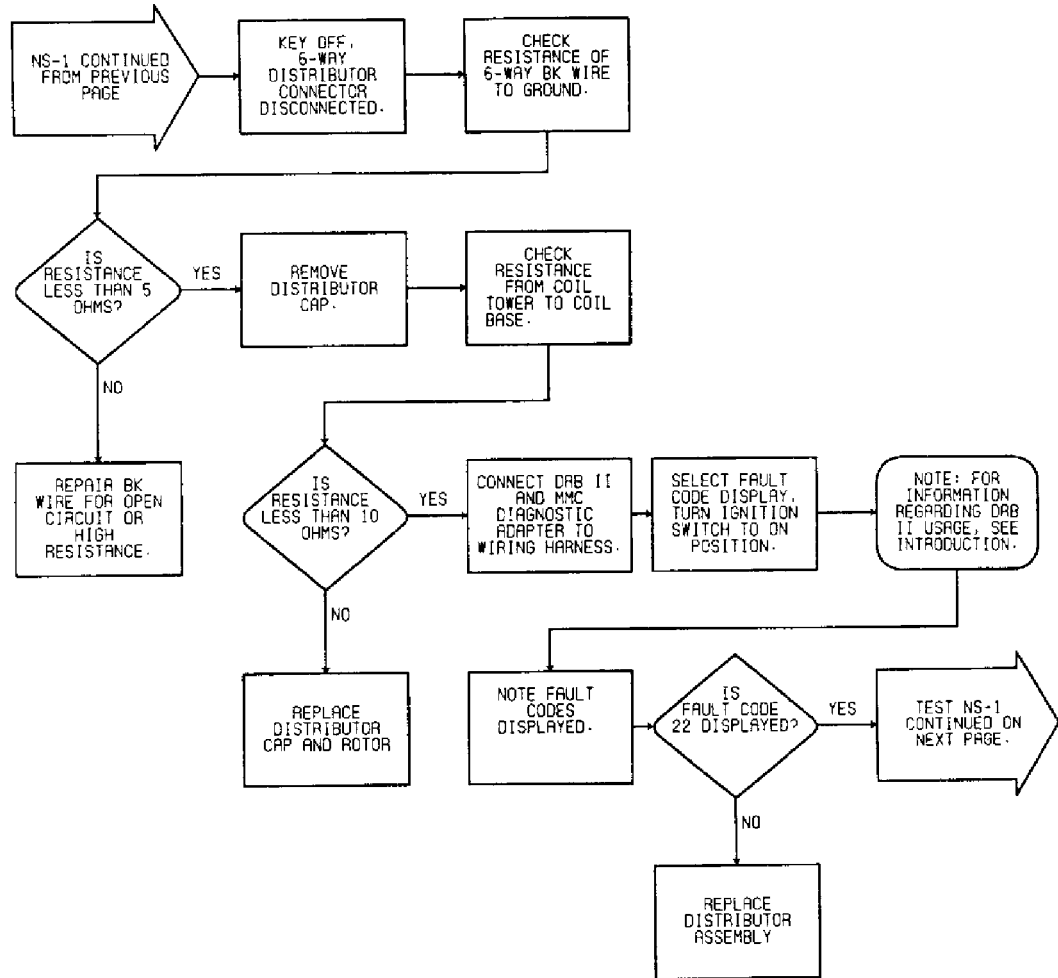

Fig. 10: No Start Test 1 Flow Chart (3 Of 5)
Ignition Check

G - TESTS W/CODES

Article Text (p. 15)

1992 Dodge Colt

For a a a a

Copyright © 1998 Mitchell Repair Information Company, LLC

Saturday, April 27, 2002 05:49PM

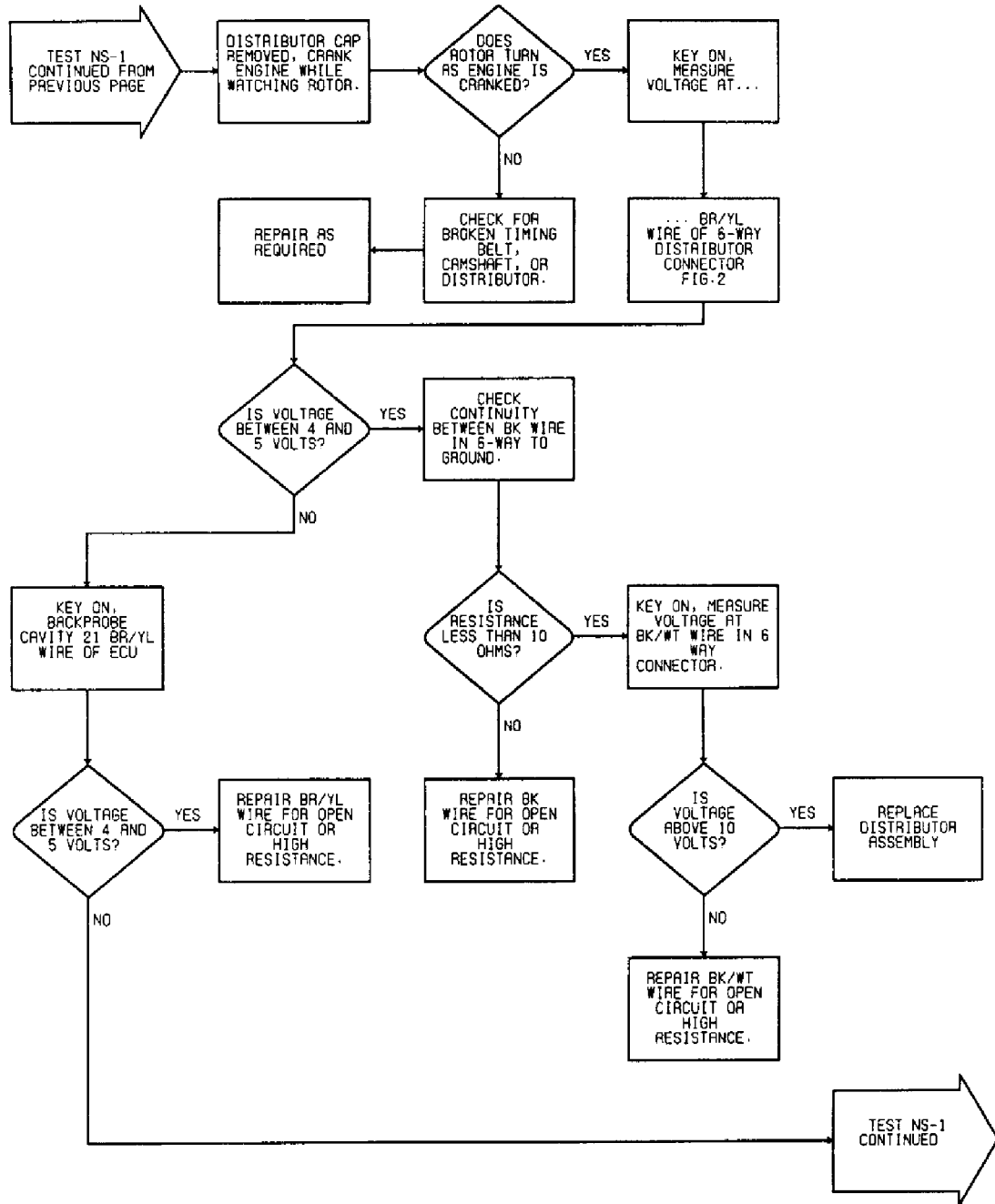

Fig. 11: No Start Test 1 Flow Chart (4 Of 5)
Ignition Check

G - TESTS W/CODES

Article Text (p. 16)

1992 Dodge Colt

For a a a a

Copyright © 1998 Mitchell Repair Information Company, LLC

Saturday, April 27, 2002 05:49PM

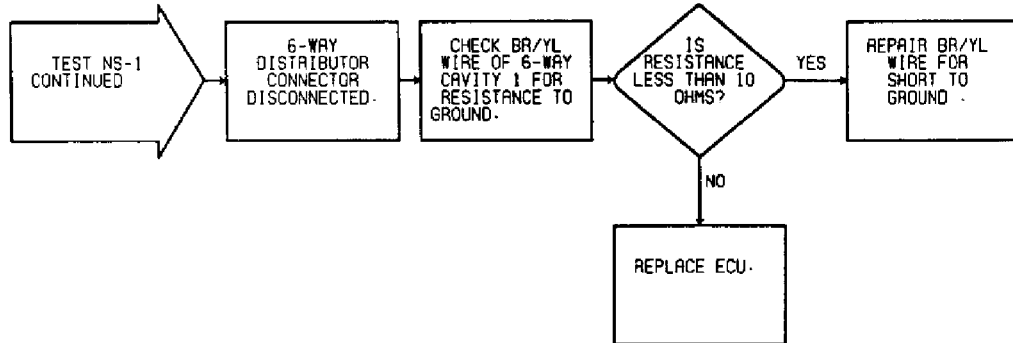

Fig. 12: No Start Test 1 Flow Chart (5 Of 5)
Ignition Check

NS-2: TESTING FOR FUEL PRESSURE

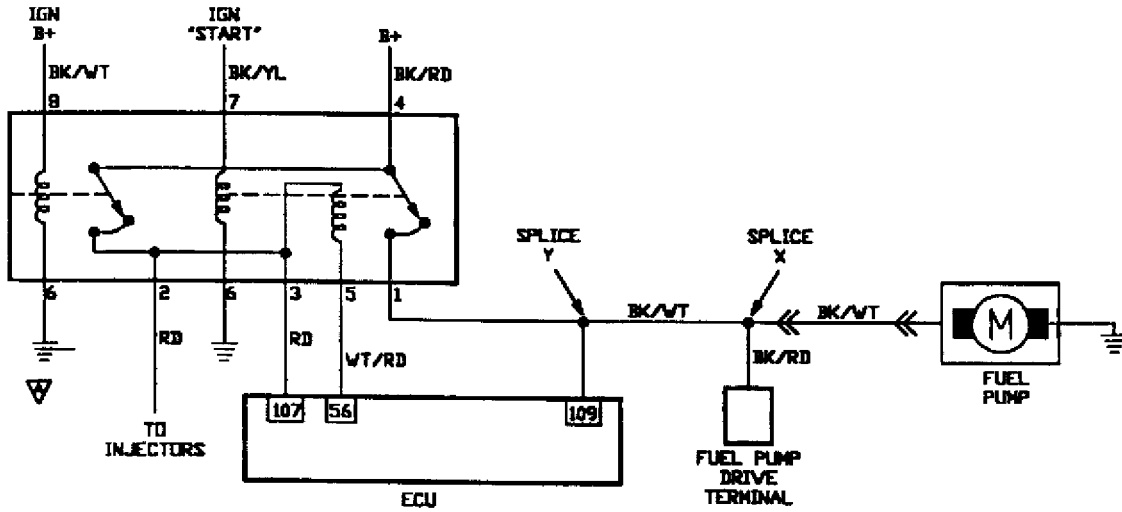

Fig. 13: No Start Test 2 Schematic
Testing For Fuel Pressure

G - TESTS W/CODES

Article Text (p. 17)

1992 Dodge Colt

For a a a a

Copyright © 1998 Mitchell Repair Information Company, LLC

Saturday, April 27, 2002 05:49PM

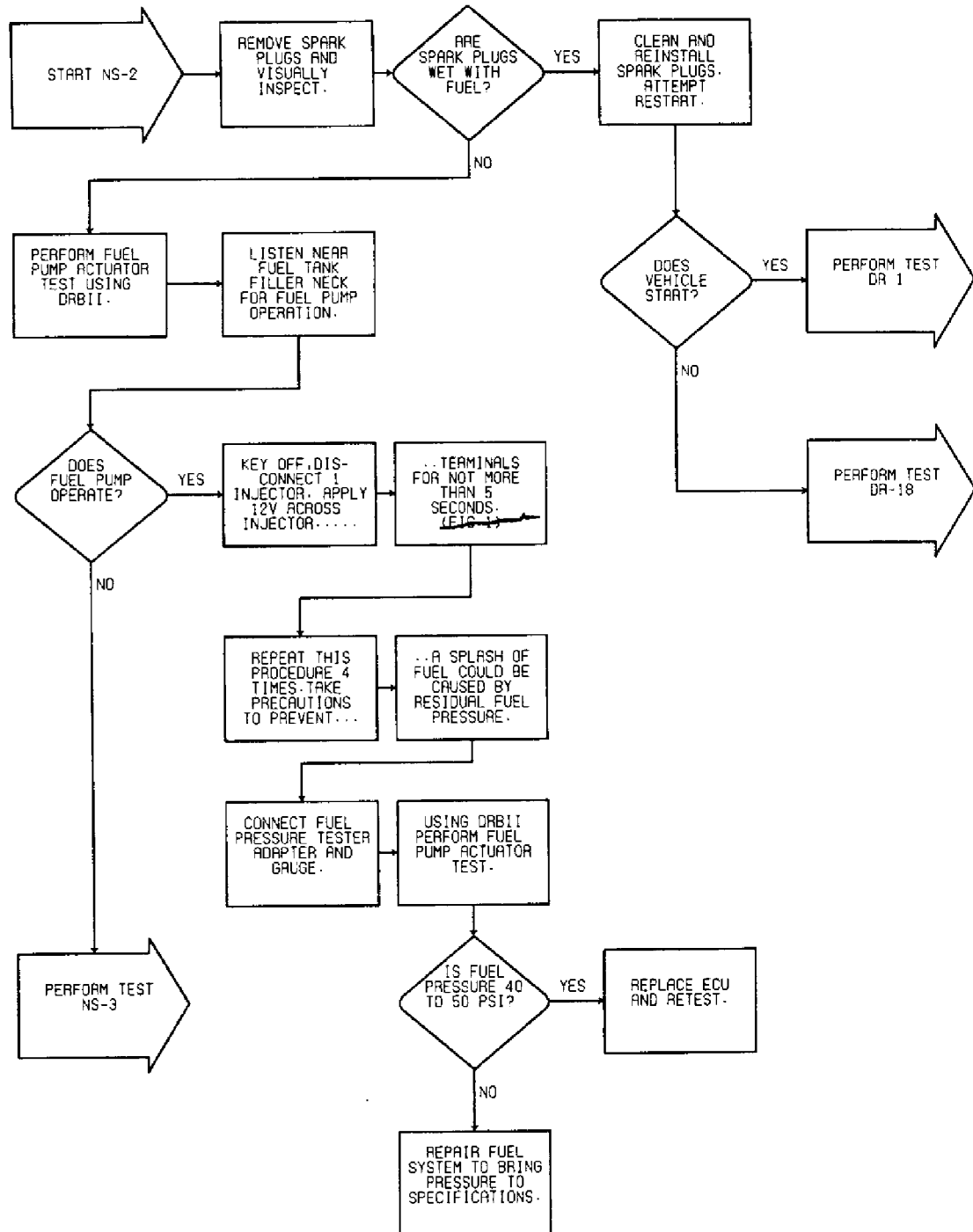

Fig. 14: No Start Test 2 Flow Chart
Testing For Fuel Pressure

NS-3: TESTING FUEL SYSTEM

G - TESTS W/CODES

Article Text (p. 18)

1992 Dodge Colt

For a a a a

Copyright © 1998 Mitchell Repair Information Company, LLC

Saturday, April 27, 2002 05:49PM

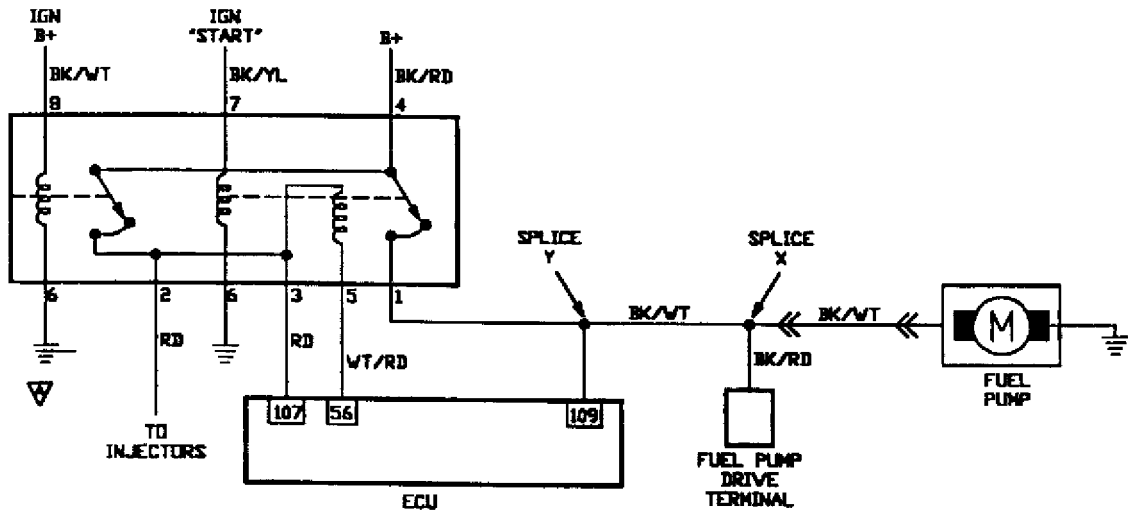

Fig. 15: No Start Test 3 Schematic
Testing Fuel System

G - TESTS W/CODES

Article Text (p. 19)

1992 Dodge Colt

For a a a a

Copyright © 1998 Mitchell Repair Information Company, LLC

Saturday, April 27, 2002 05:49PM

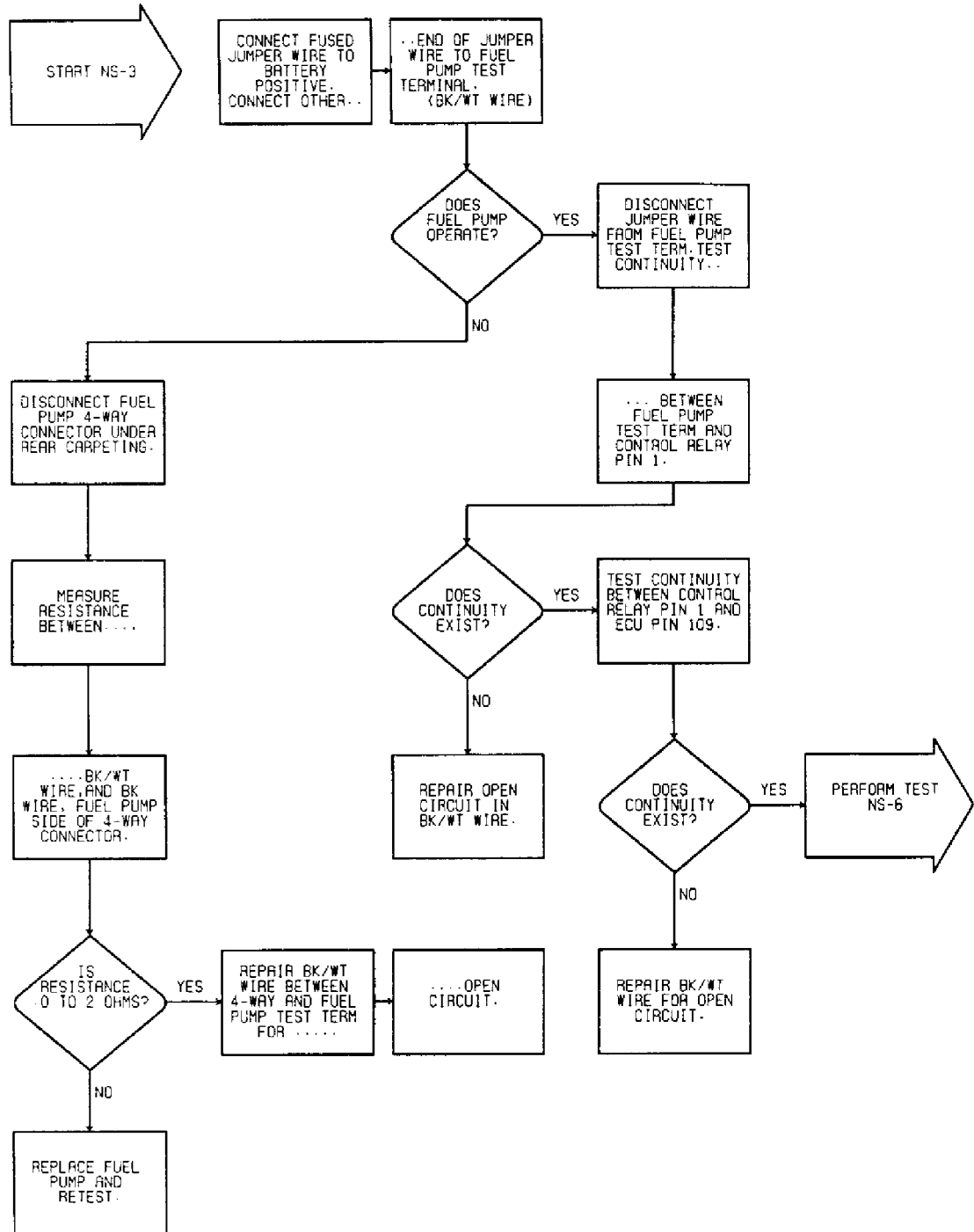

Fig. 16: No Start Test 3 Flow Chart Testing Fuel System

NS-4: CHECKING IGNITION SYSTEM

G - TESTS W/CODES

Article Text (p. 20)

1992 Dodge Colt

For a a a a

Copyright © 1998 Mitchell Repair Information Company, LLC

Saturday, April 27, 2002 05:49PM

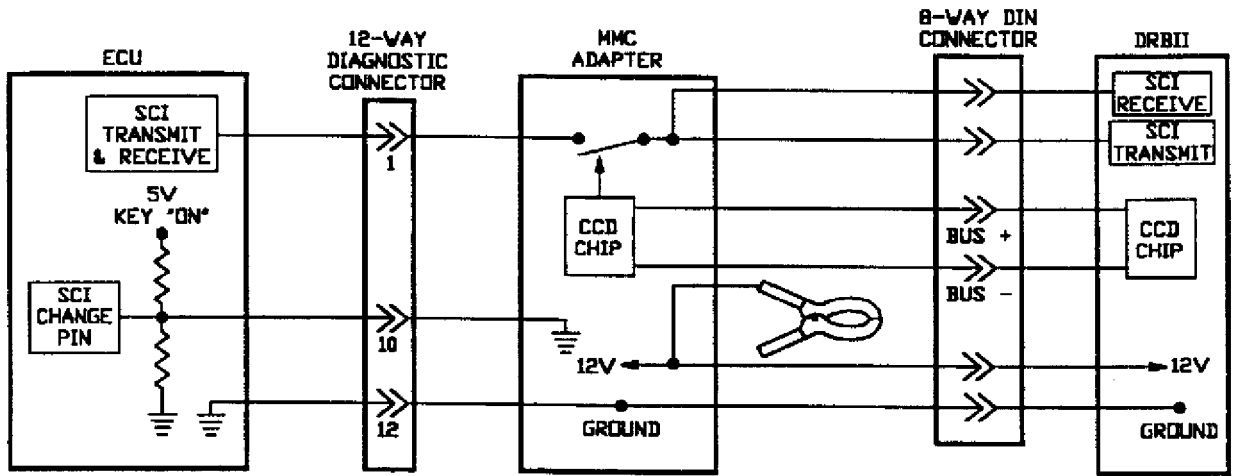

Fig. 17: No Start Test 4 Schematic
Checking Ignition System

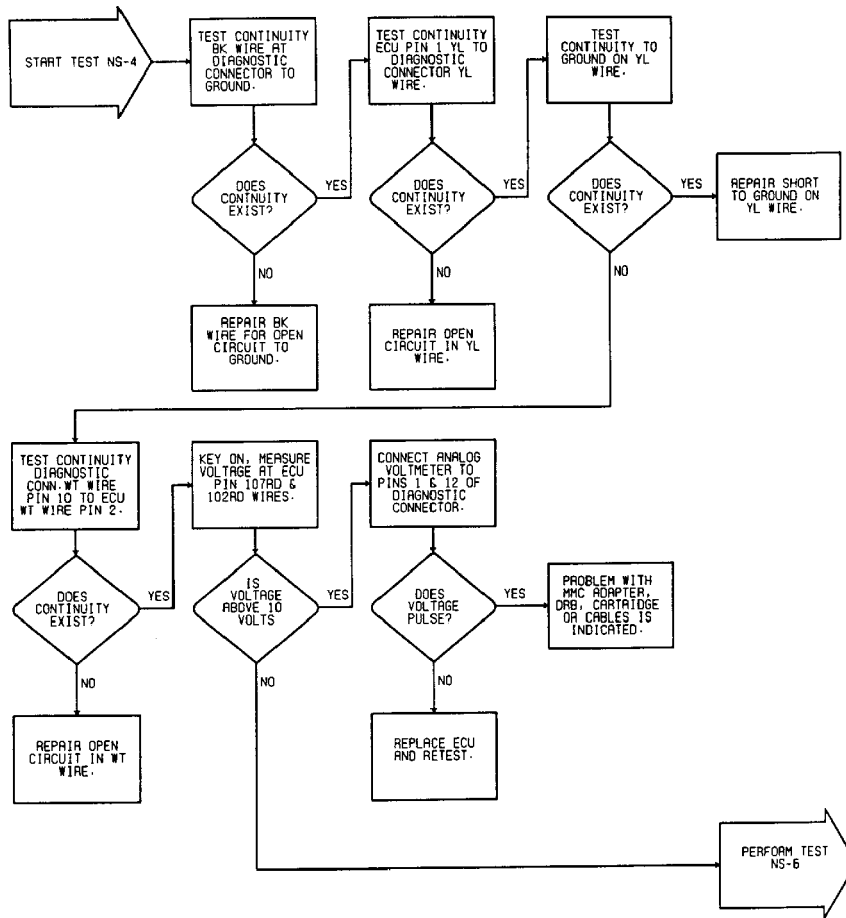

Fig. 18: No Start Test 4 Flow Chart
Checking Ignition System

G - TESTS W/CODES

Article Text (p. 21)

1992 Dodge Colt

For a a a a

Copyright © 1998 Mitchell Repair Information Company, LLC

Saturday, April 27, 2002 05:49PM

NS-5: TESTING CRANK ANGLE SENSOR

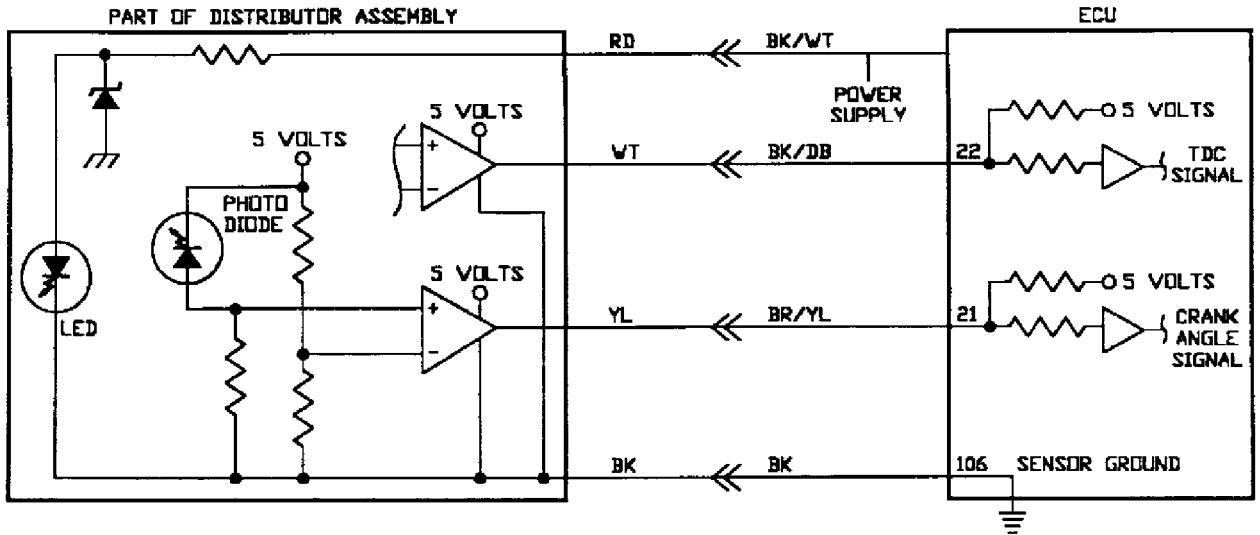

Fig. 19: No Start Test 5 Schematic
Testing Crank Angle Sensor

G - TESTS W/CODES

Article Text (p. 22)

1992 Dodge Colt

For a a a a

Copyright © 1998 Mitchell Repair Information Company, LLC

Saturday, April 27, 2002 05:49PM

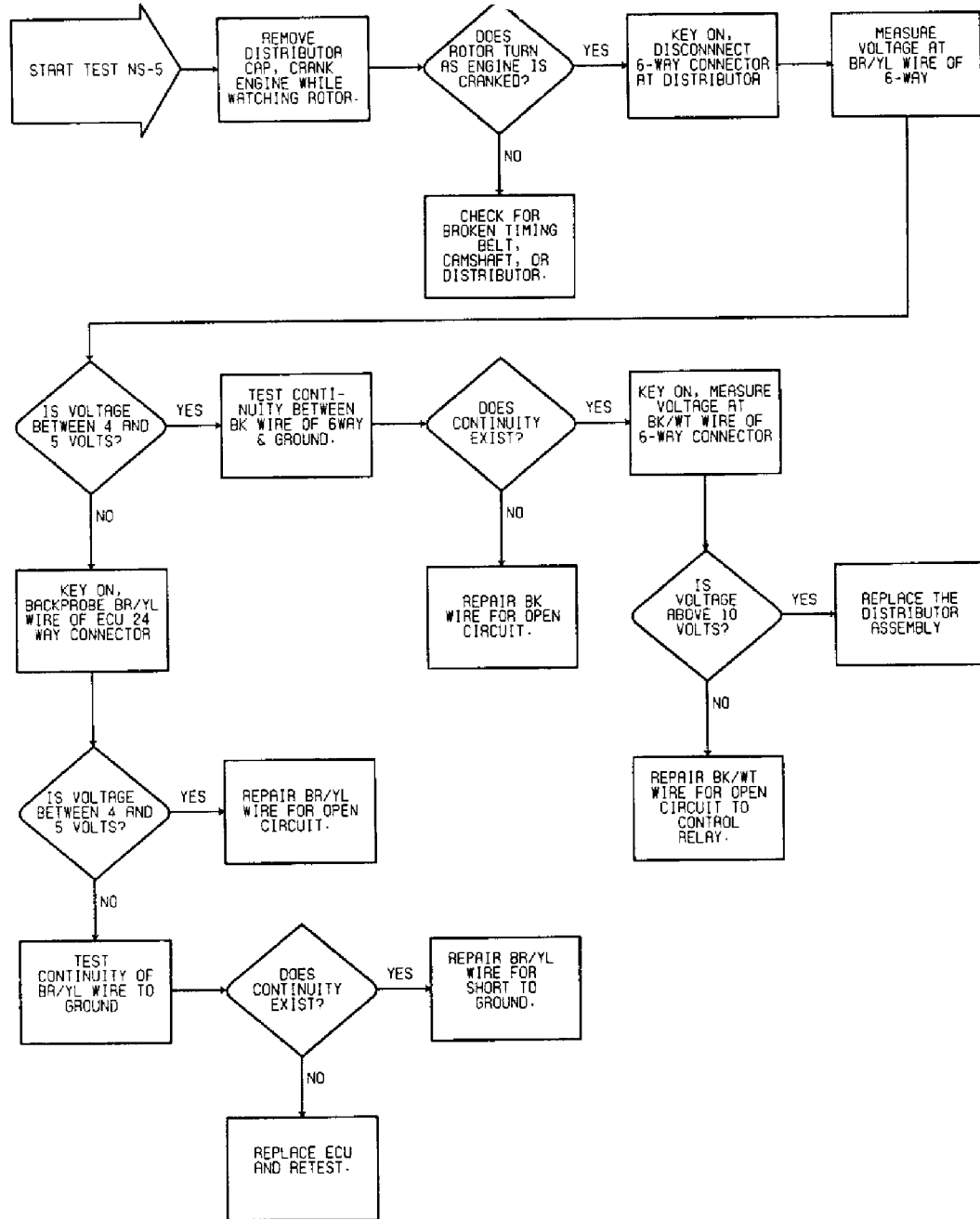

Fig. 20: No Start Test 5 Flow Chart
Testing Crank Angle Sensor

NS-6: TESTING CONTROL RELAY

G - TESTS W/CODES

Article Text (p. 23)

1992 Dodge Colt

For a a a a

Copyright © 1998 Mitchell Repair Information Company, LLC

Saturday, April 27, 2002 05:49PM

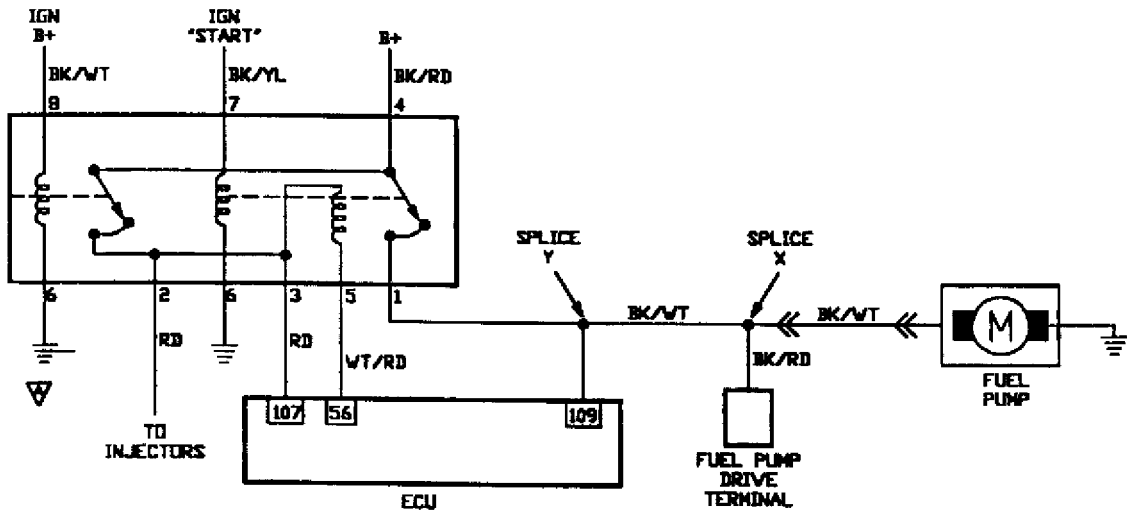

Fig. 21: No Start Test 6 Schematic Testing Control Relay

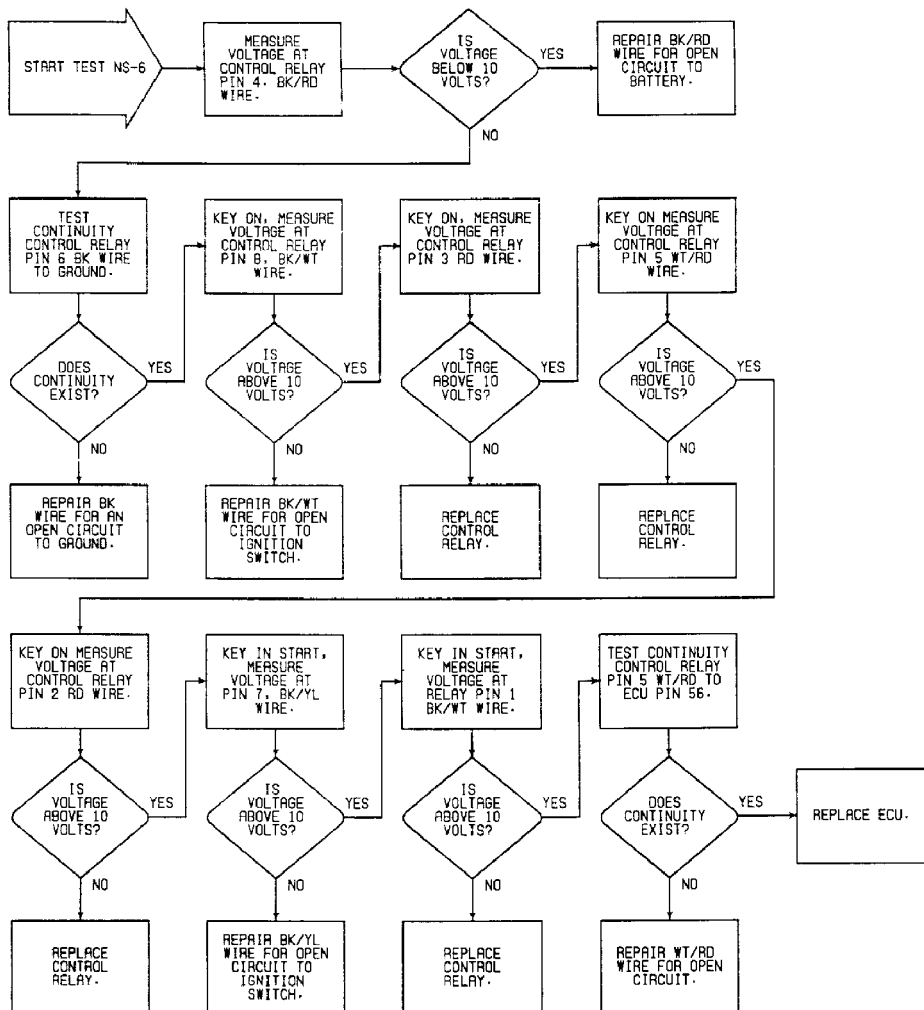

Fig. 22: No Start Test 6 Flow Chart Testing Control Relay

G - TESTS W/CODES

Article Text (p. 24)

1992 Dodge Colt

For a a a a

Copyright © 1998 Mitchell Repair Information Company, LLC

Saturday, April 27, 2002 05:49PM

DR-1: TESTING FOR MPI SYSTEM FAULT CODES

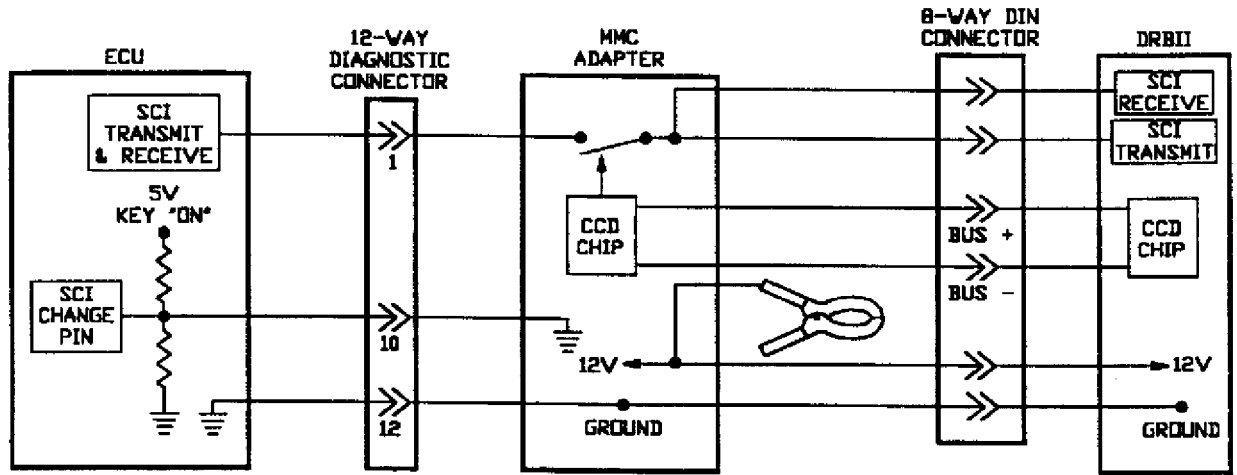

Fig. 23: DR-1 Test Schematic
MPI System Fault Codes

G - TESTS W/CODES

Article Text (p. 25)

1992 Dodge Colt

For a a a a

Copyright © 1998 Mitchell Repair Information Company, LLC

Saturday, April 27, 2002 05:49PM

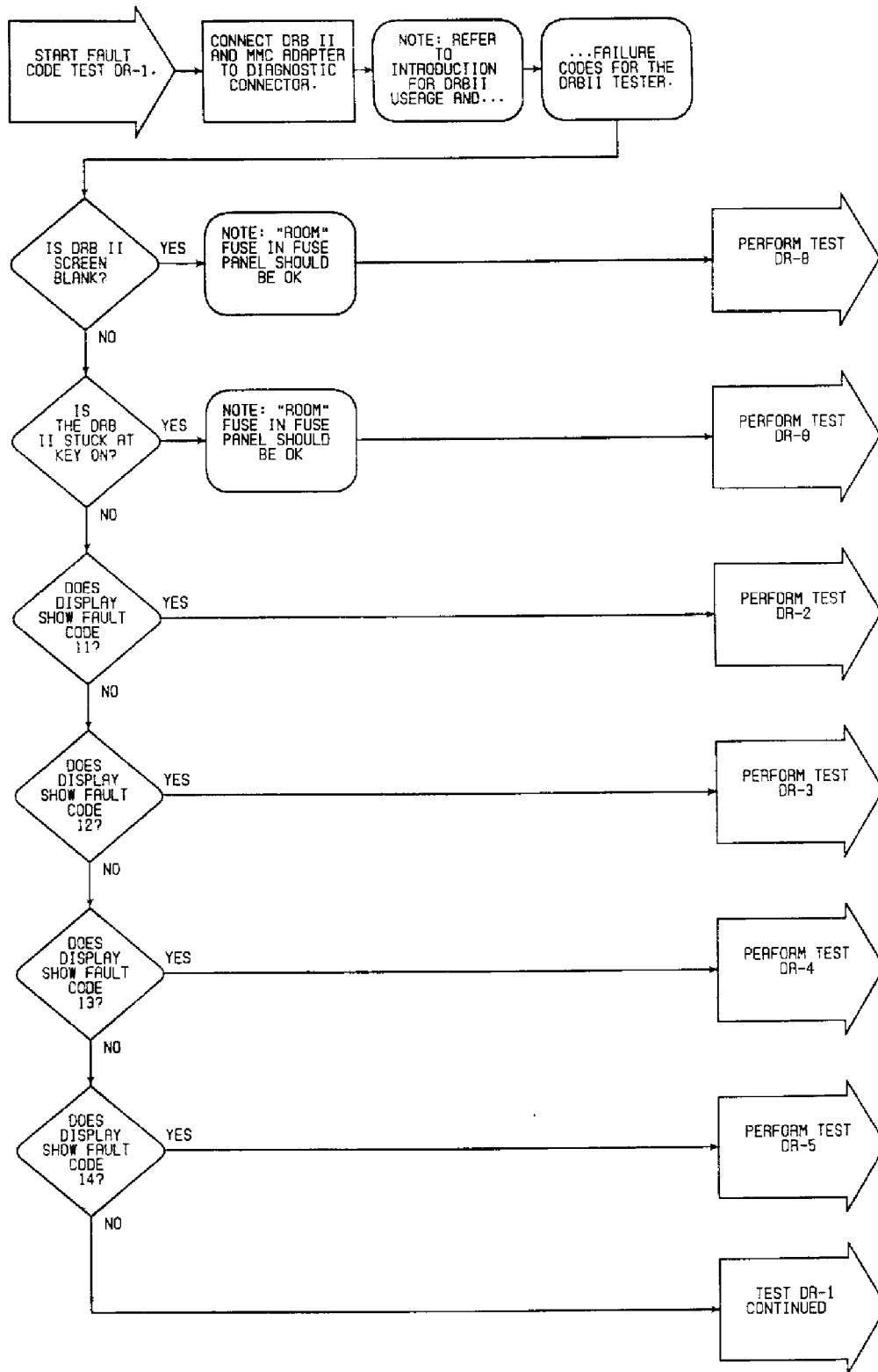

Fig. 24: DR-1 Test Flow Chart (1 Of 2)
MPI System Fault Codes

G - TESTS W/CODES

Article Text (p. 26)

1992 Dodge Colt

For a a a a

Copyright © 1998 Mitchell Repair Information Company, LLC

Saturday, April 27, 2002 05:49PM

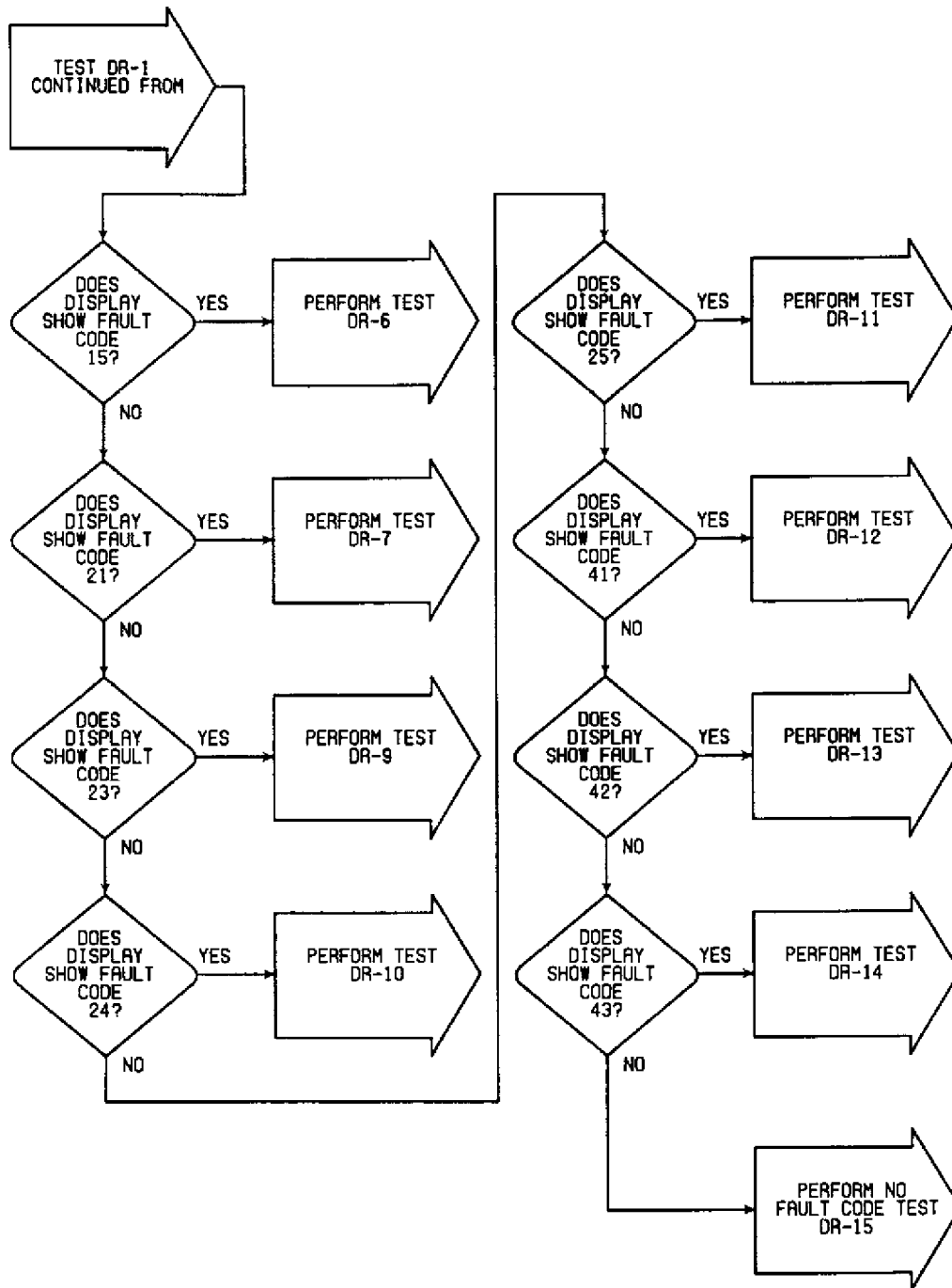

Fig. 25: DR-1 Test Flow Chart (2 Of 2)
MPI System Fault Codes

DR-2: TESTING OXYGEN SENSOR CIRCUIT

G - TESTS W/CODES

Article Text (p. 27)

1992 Dodge Colt

For a a a a

Copyright © 1998 Mitchell Repair Information Company, LLC

Saturday, April 27, 2002 05:49PM

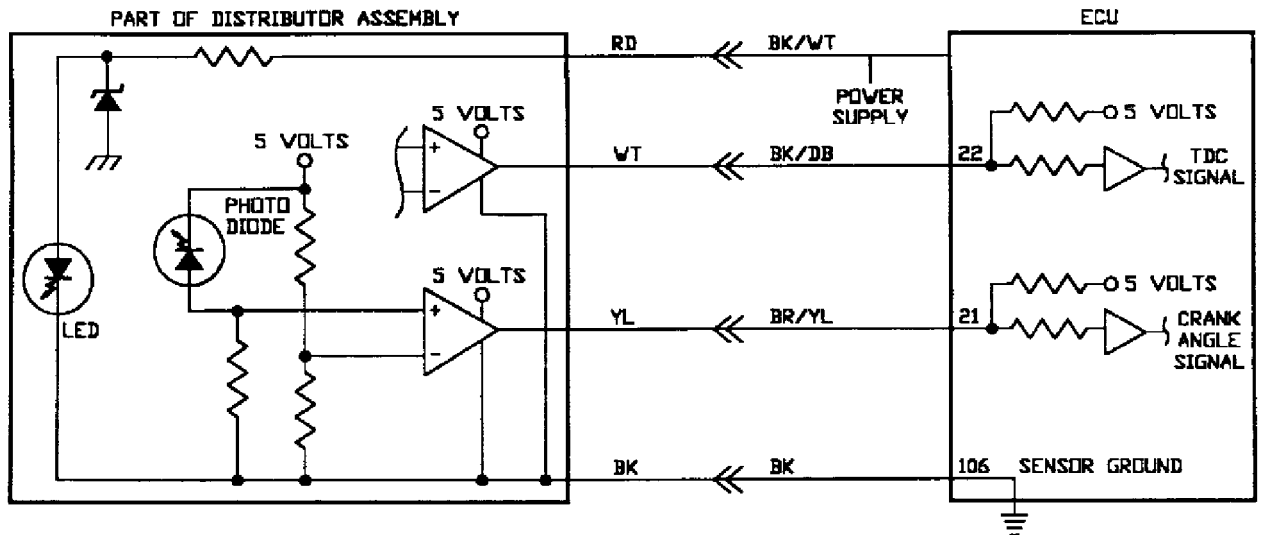

Fig. 26: DR-2 Test Schematic
Testing Oxygen Sensor Circuit

G - TESTS W/CODES

Article Text (p. 28)

1992 Dodge Colt

For a a a a

Copyright © 1998 Mitchell Repair Information Company, LLC

Saturday, April 27, 2002 05:50PM

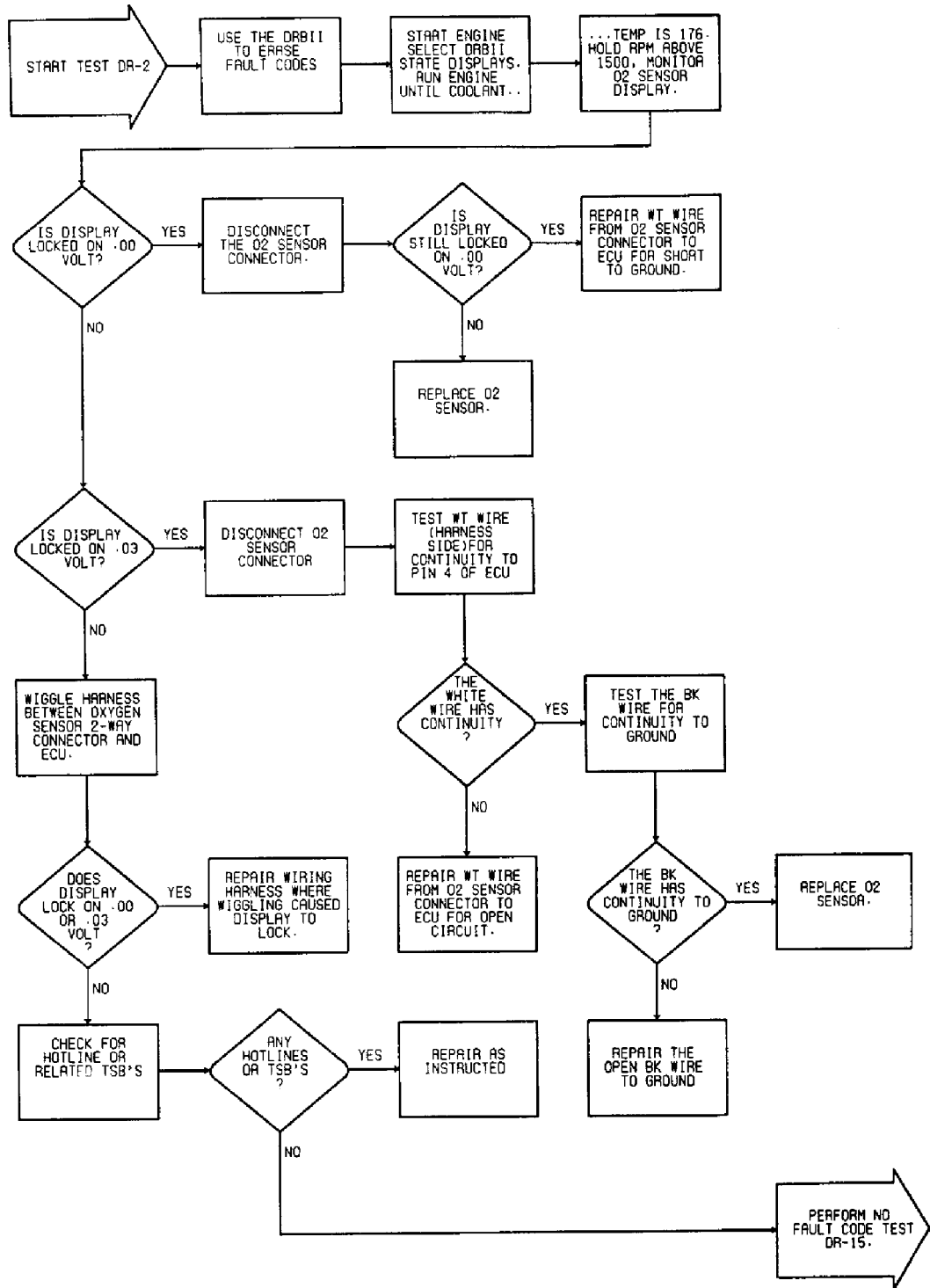

Fig. 27: DR-2 Test Flow Chart Testing Oxygen Sensor Circuit

G - TESTS W/CODES

Article Text (p. 29)

1992 Dodge Colt

For a a a a

Copyright © 1998 Mitchell Repair Information Company, LLC
Saturday, April 27, 2002 05:50PM

DR-3: TESTING AIRFLOW SENSOR CIRCUIT

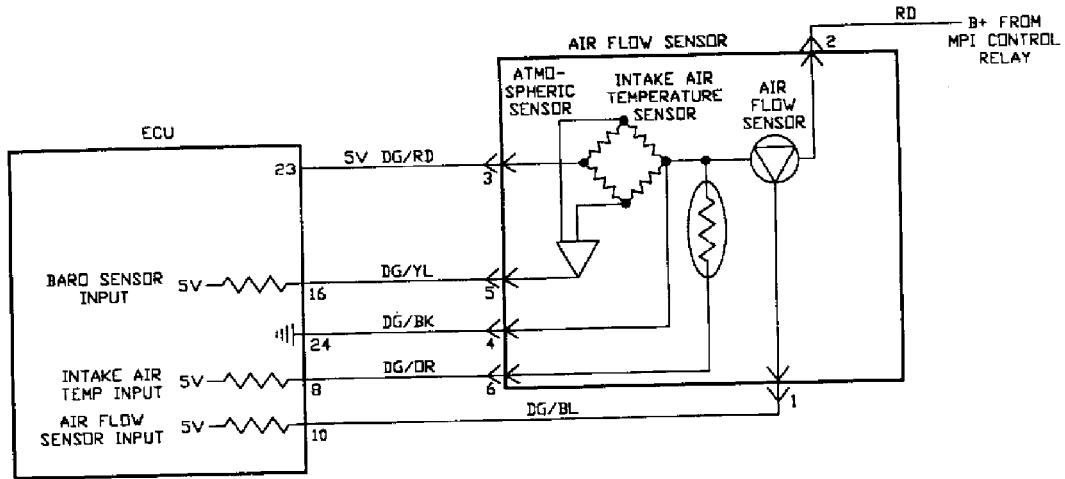

Fig. 28: DR-3 Test Schematic
Testing Airflow Sensor Circuit

G - TESTS W/CODES

Article Text (p. 30)

1992 Dodge Colt

For a a a a

Copyright © 1998 Mitchell Repair Information Company, LLC

Saturday, April 27, 2002 05:50PM

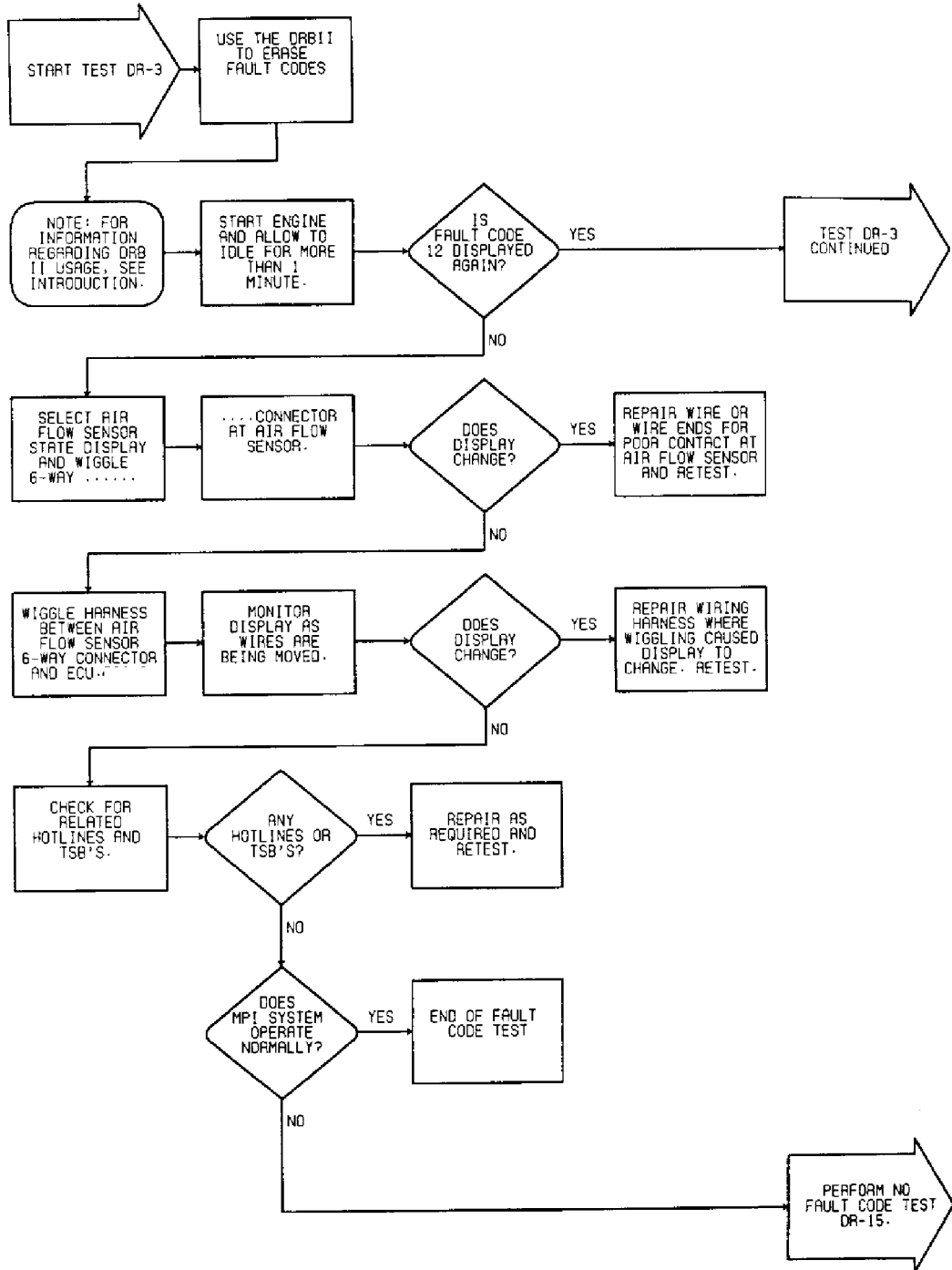

Fig. 29: DR-3 Test Flow Chart (1 Of 3)
Testing Airflow Sensor Circuit

G - TESTS W/CODES

Article Text (p. 31)

1992 Dodge Colt

For a a a a

Copyright © 1998 Mitchell Repair Information Company, LLC

Saturday, April 27, 2002 05:50PM

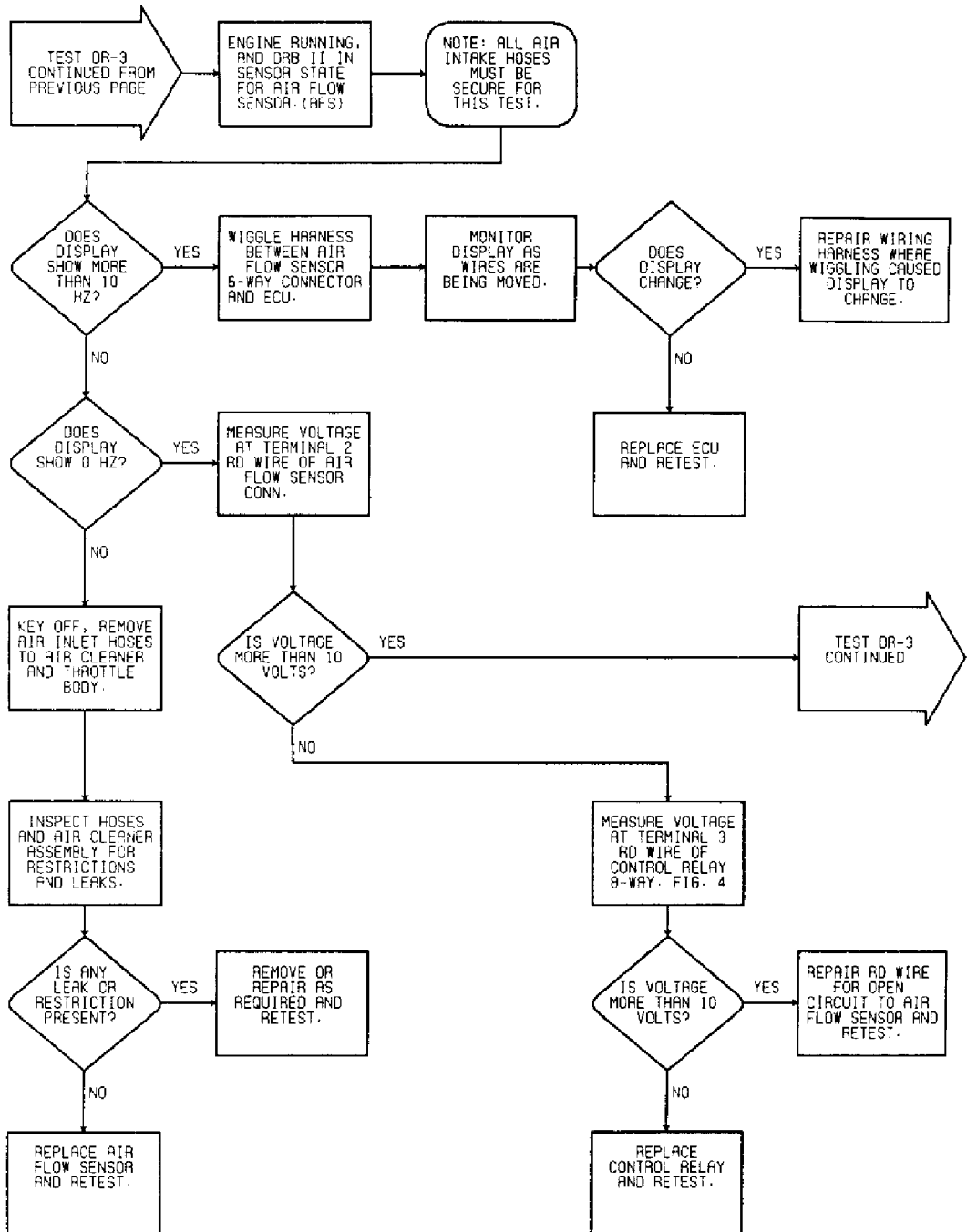

Fig. 30: DR-3 Test Flow Chart (2 Of 3)
Testing Airflow Sensor Circuit

G - TESTS W/CODES

Article Text (p. 32)

1992 Dodge Colt

For a a a a

Copyright © 1998 Mitchell Repair Information Company, LLC

Saturday, April 27, 2002 05:50PM

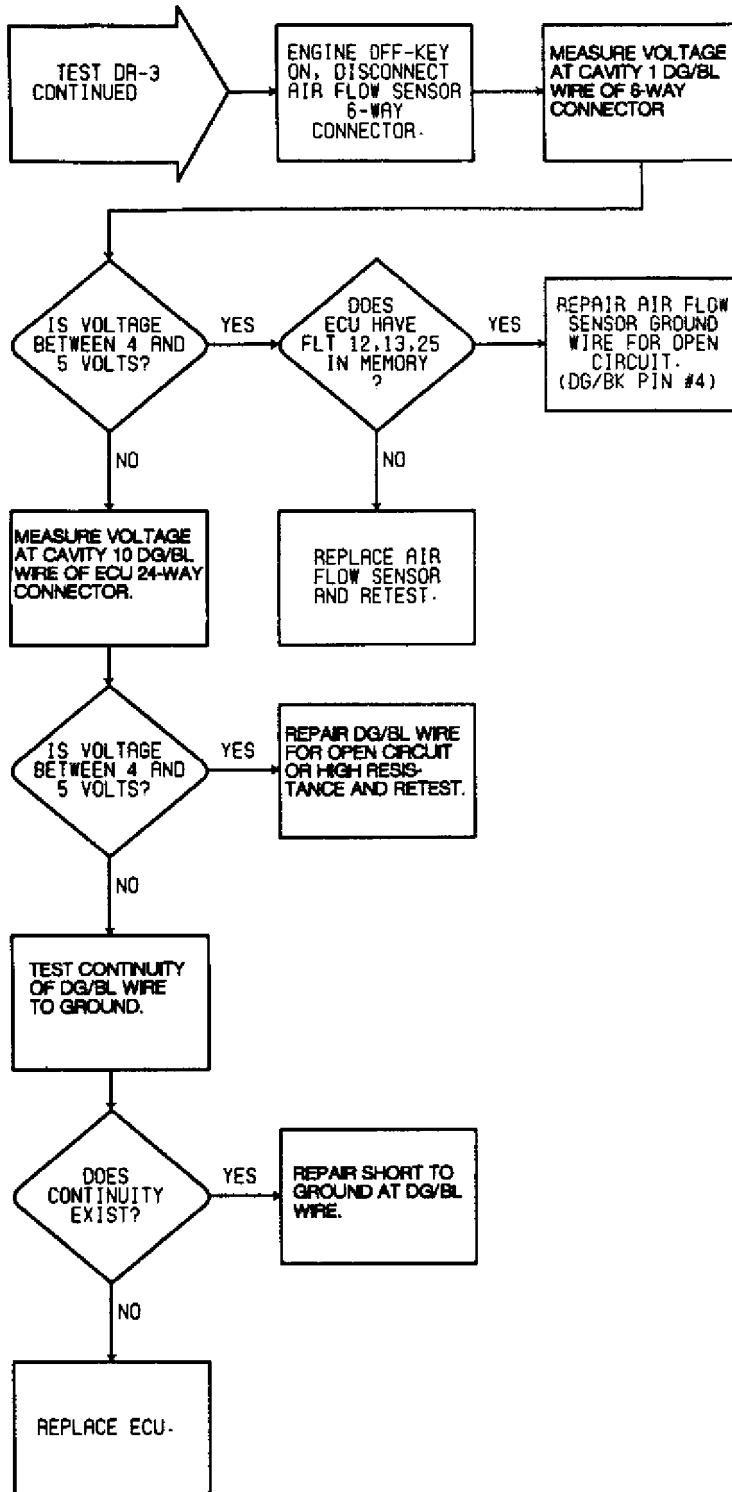

Fig. 31: DR-3 Test Flow Chart (3 Of 3)
Testing Airflow Sensor Circuit

DR-4: TESTING INTAKE AIR TEMP. SENSOR CIRCUIT

G - TESTS W/CODES

Article Text (p. 33)

1992 Dodge Colt

For a a a a

Copyright © 1998 Mitchell Repair Information Company, LLC
Saturday, April 27, 2002 05:50PM

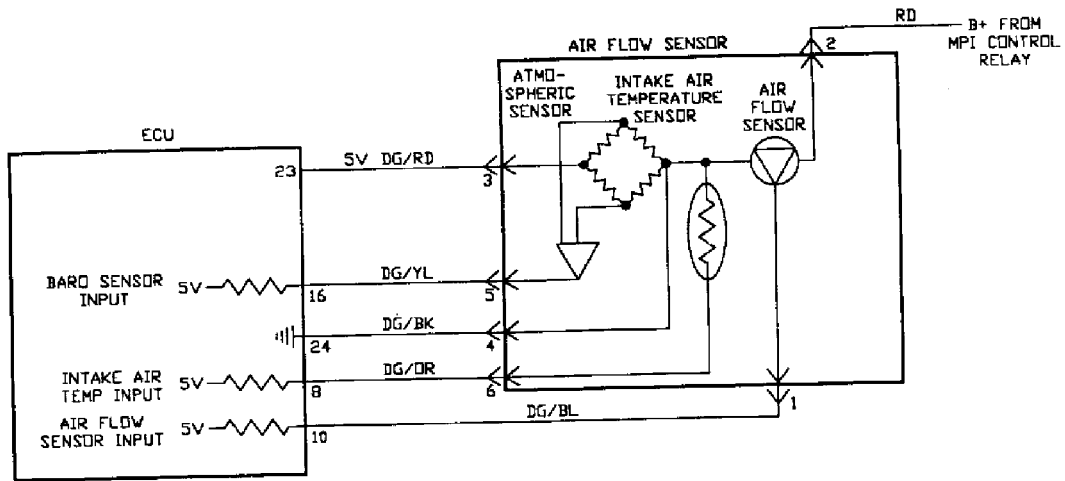

Fig. 32: DR-4 Test Schematic
Testing Intake Air Temperature Sensor Circuit

G - TESTS W/CODES

Article Text (p. 34)

1992 Dodge Colt

For a a a a

Copyright © 1998 Mitchell Repair Information Company, LLC

Saturday, April 27, 2002 05:50PM

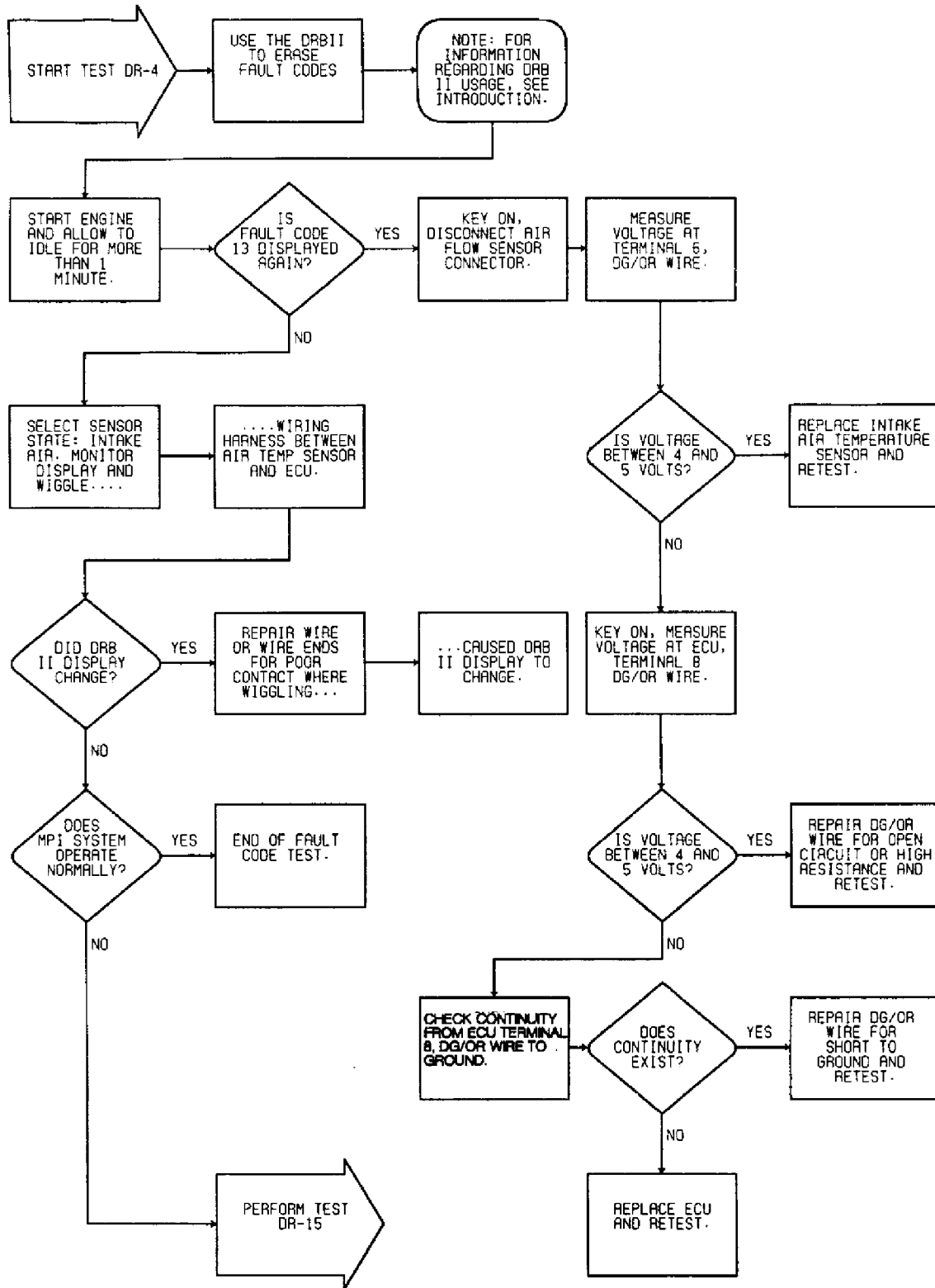

Fig. 33: DR-4 Test Flow Chart
Testing Intake Air Temperature Sensor Circuit

G - TESTS W/CODES

Article Text (p. 35)

1992 Dodge Colt

For a a a a

Copyright © 1998 Mitchell Repair Information Company, LLC

Saturday, April 27, 2002 05:50PM

DR-5: TESTING THROTTLE POSITION SENSOR CIRCUIT

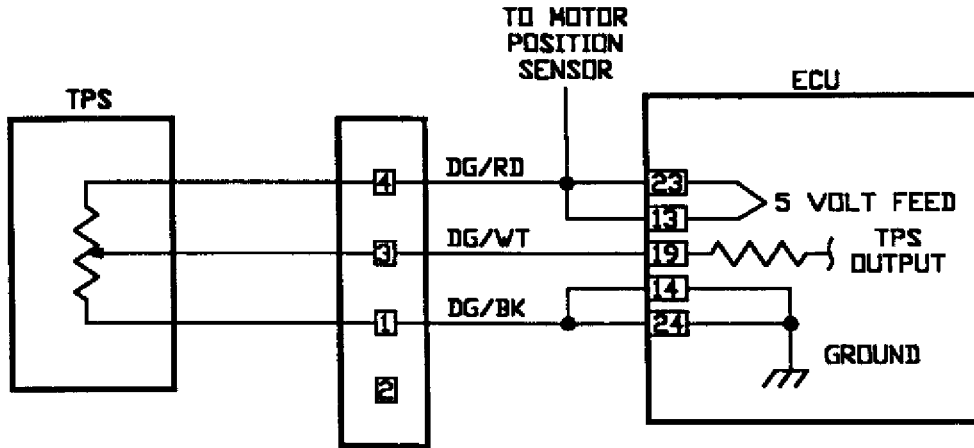

Fig. 34: DR-5 Test Schematic
Testing Throttle Position Sensor Circuit

G - TESTS W/CODES

Article Text (p. 36)

1992 Dodge Colt

For a a a a

Copyright © 1998 Mitchell Repair Information Company, LLC

Saturday, April 27, 2002 05:50PM

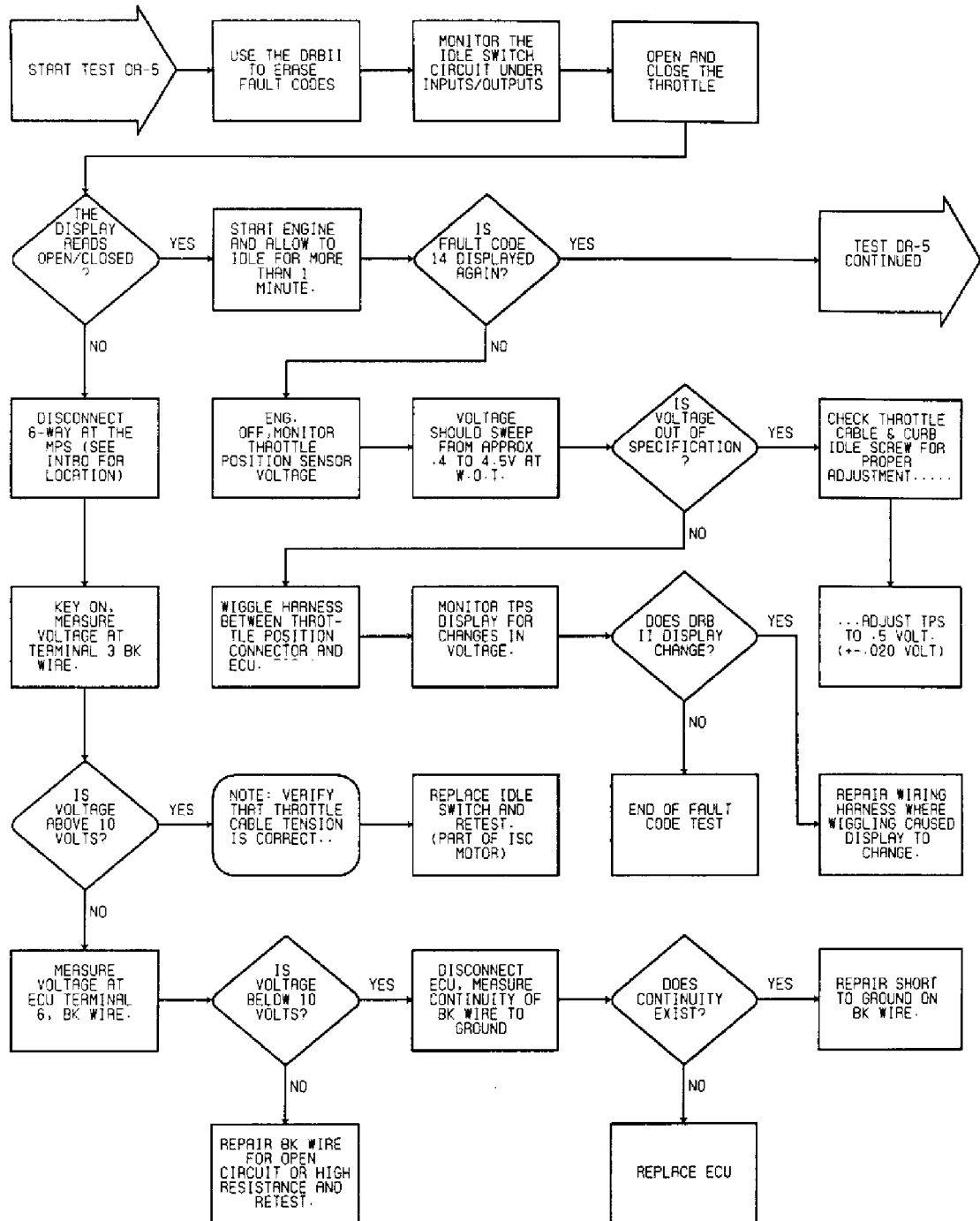

Fig. 35: DR-5 Test Flow Chart (1 Of 2)
Testing Throttle Position Sensor Circuit

G - TESTS W/CODES

Article Text (p. 37)

1992 Dodge Colt

For a a a a

Copyright © 1998 Mitchell Repair Information Company, LLC

Saturday, April 27, 2002 05:50PM

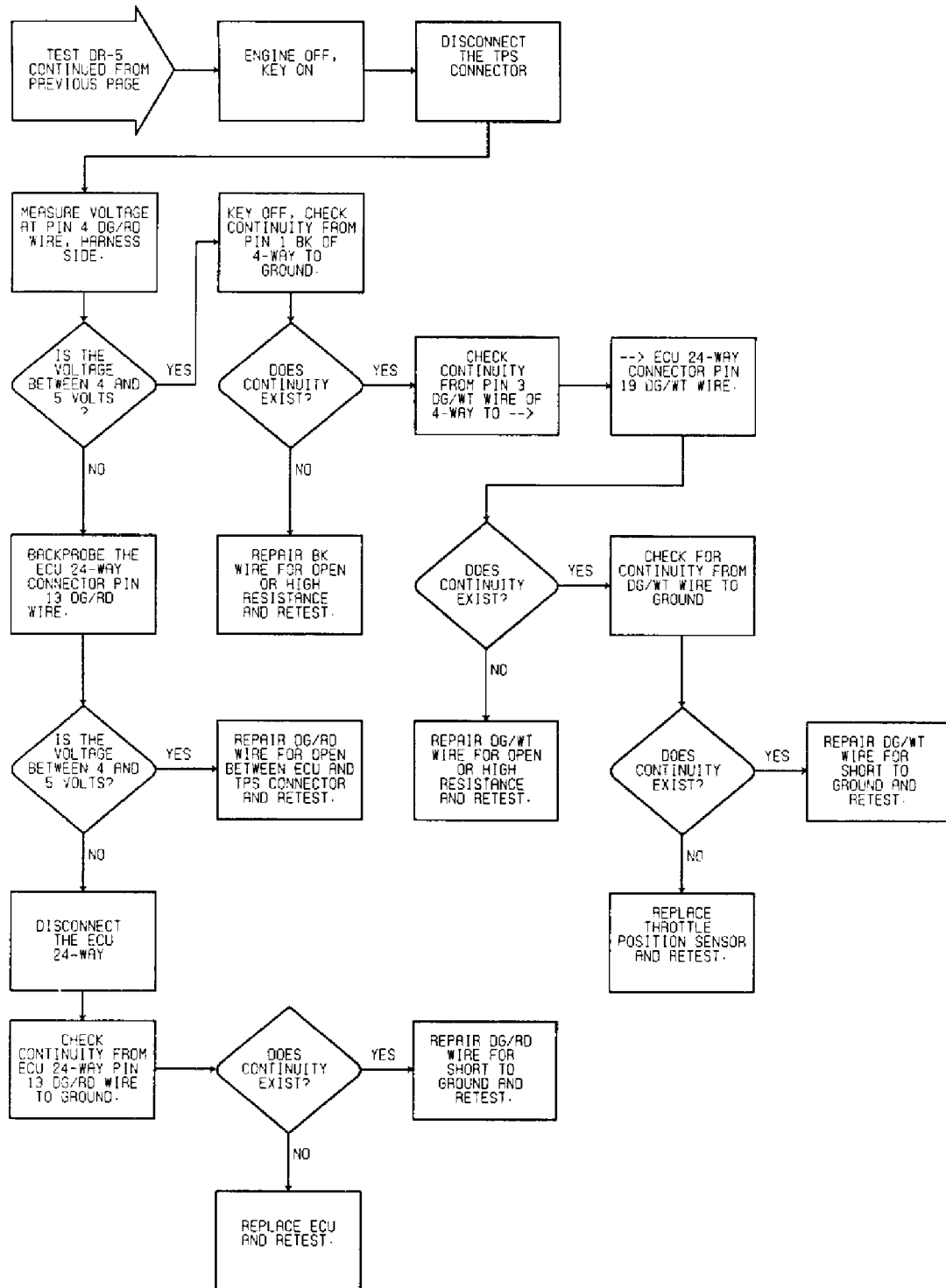

Fig. 36: DR-5 Test Flow Chart (2 Of 2)
Testing Throttle Position Sensor Circuit

G - TESTS W/CODES

Article Text (p. 38)

1992 Dodge Colt

For a a a a

Copyright © 1998 Mitchell Repair Information Company, LLC

Saturday, April 27, 2002 05:50PM

DR-6: TESTING MOTOR POSITION SENSOR

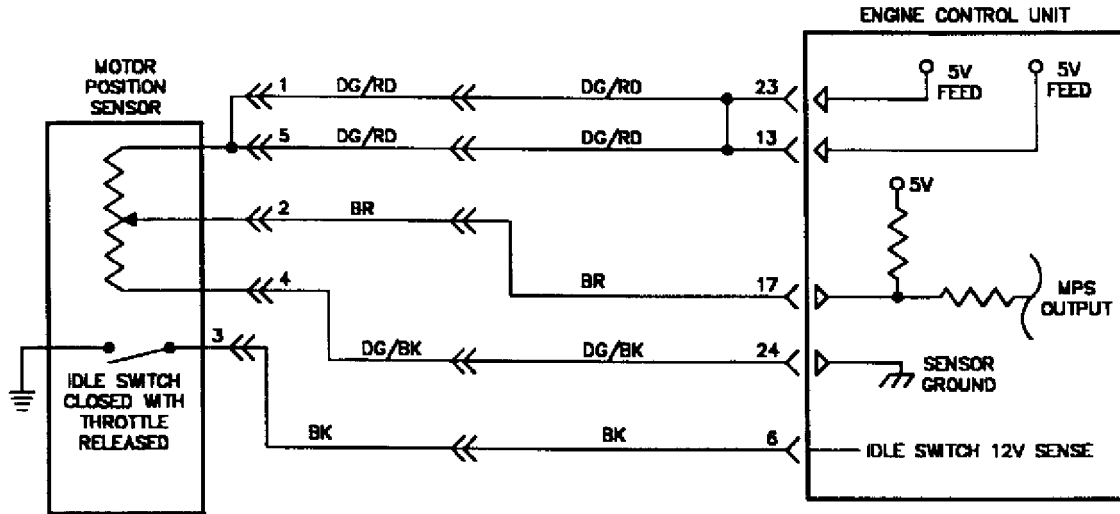

Fig. 37: DR-6 Test Schematic
Testing Motor Position Sensor

G - TESTS W/CODES

Article Text (p. 39)

1992 Dodge Colt

For a a a a

Copyright © 1998 Mitchell Repair Information Company, LLC

Saturday, April 27, 2002 05:50PM

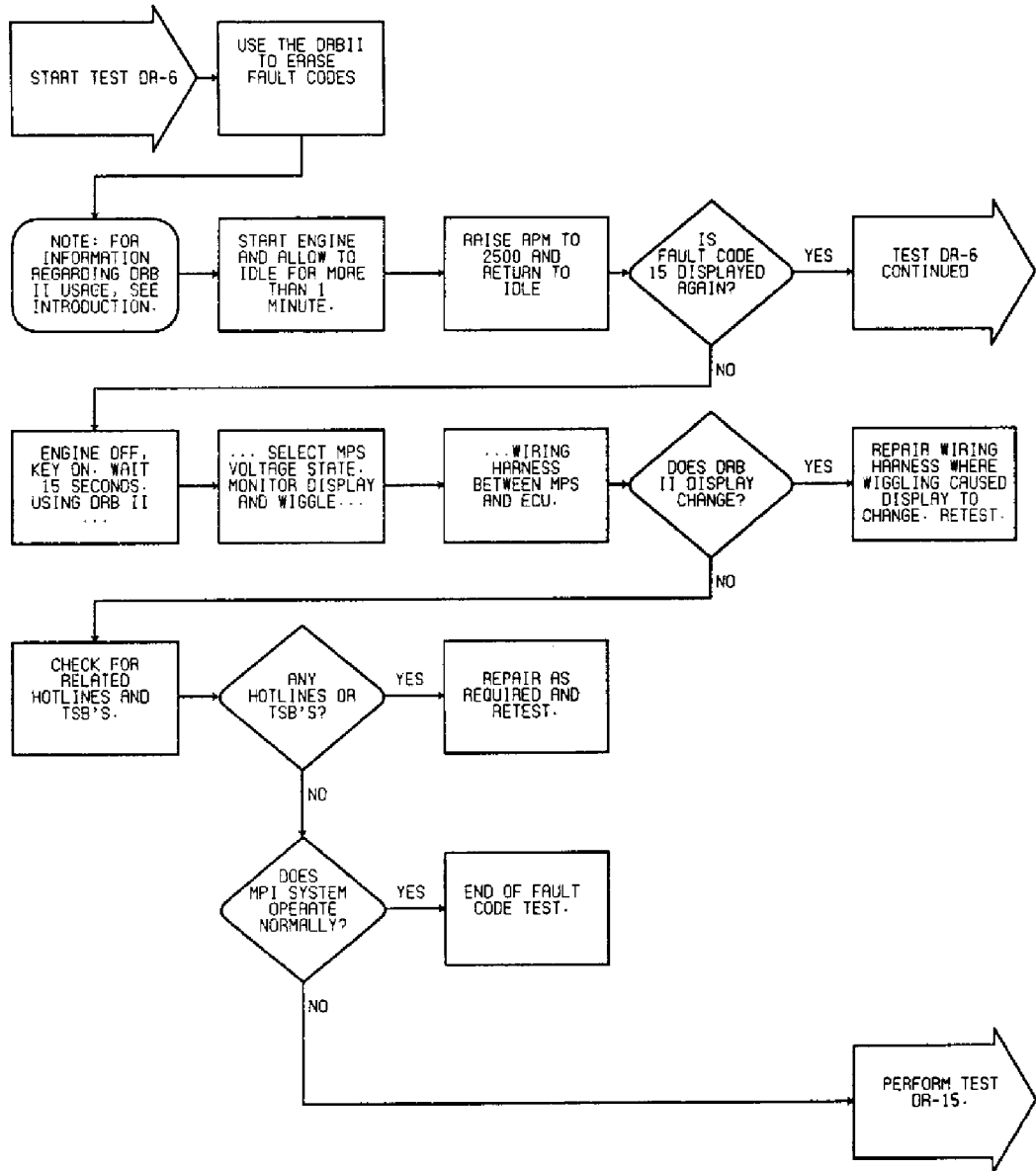

Fig. 38: DR-6 Test Flow Chart (1 Of 2)
Testing Motor Position Sensor

G - TESTS W/CODES

Article Text (p. 40)

1992 Dodge Colt

For a a a a

Copyright © 1998 Mitchell Repair Information Company, LLC

Saturday, April 27, 2002 05:50PM

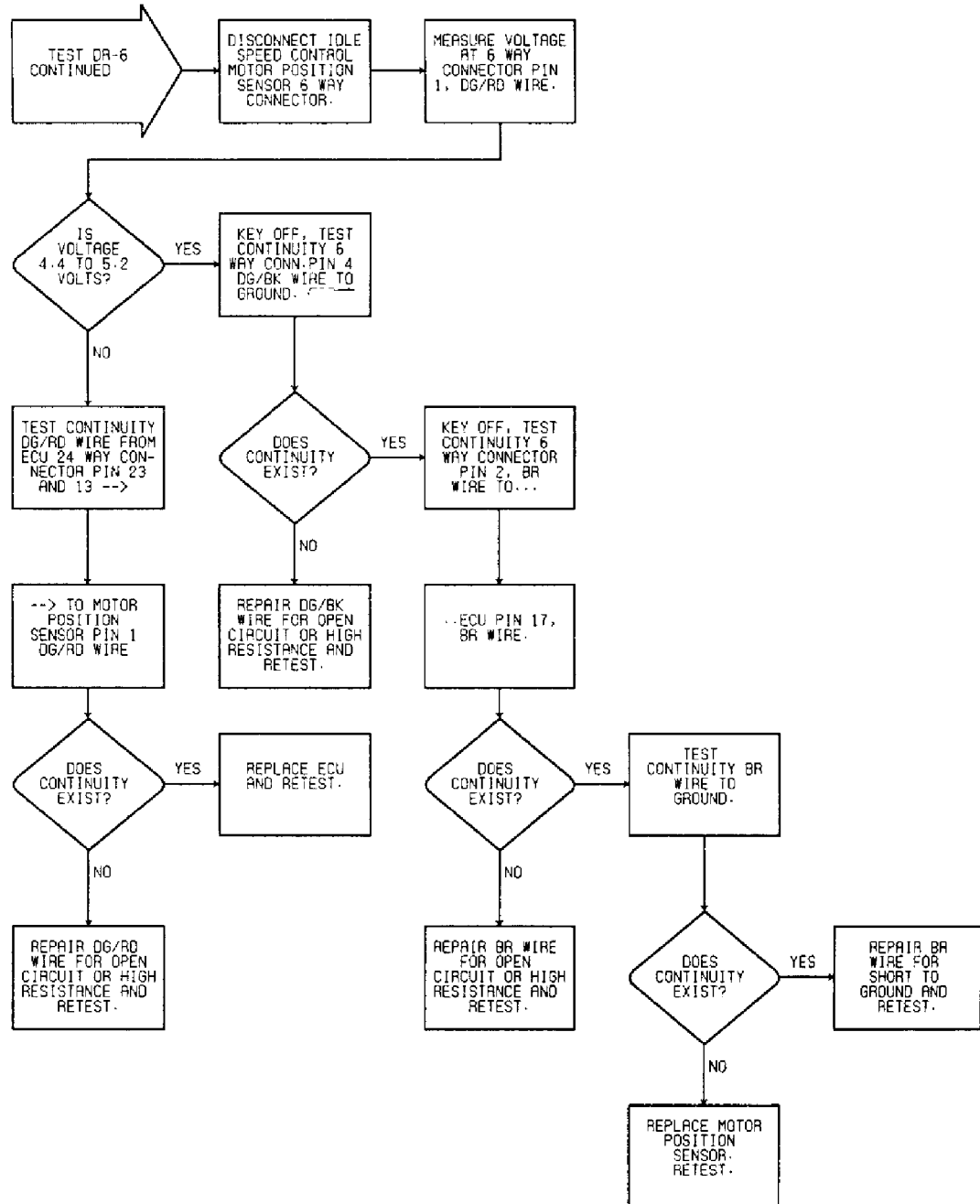

Fig. 39: DR-6 Test Flow Chart (2 Of 2) Testing Motor Position Sensor

DR-7: TESTING COOLANT SENSOR

G - TESTS W/CODES

Article Text (p. 41)

1992 Dodge Colt

For a a a a

Copyright © 1998 Mitchell Repair Information Company, LLC

Saturday, April 27, 2002 05:50PM

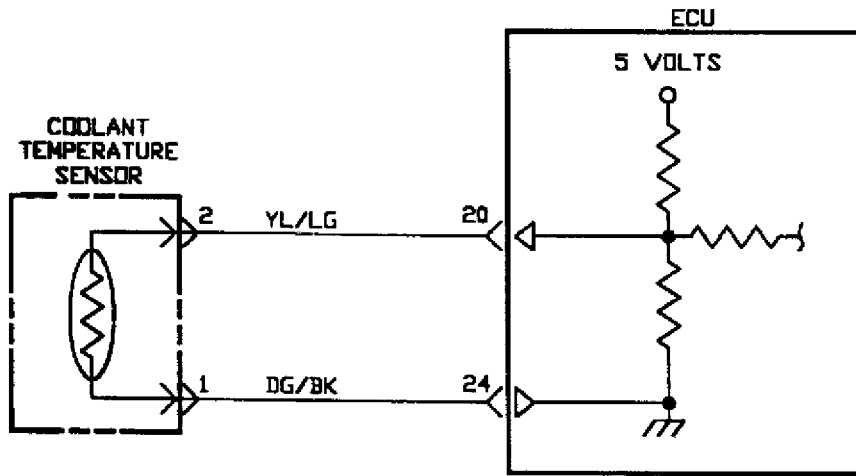

Fig. 40: DR-7 Test Schematic
Testing Coolant Sensor

G - TESTS W/CODES

Article Text (p. 42)

1992 Dodge Colt

For a a a a

Copyright © 1998 Mitchell Repair Information Company, LLC

Saturday, April 27, 2002 05:50PM

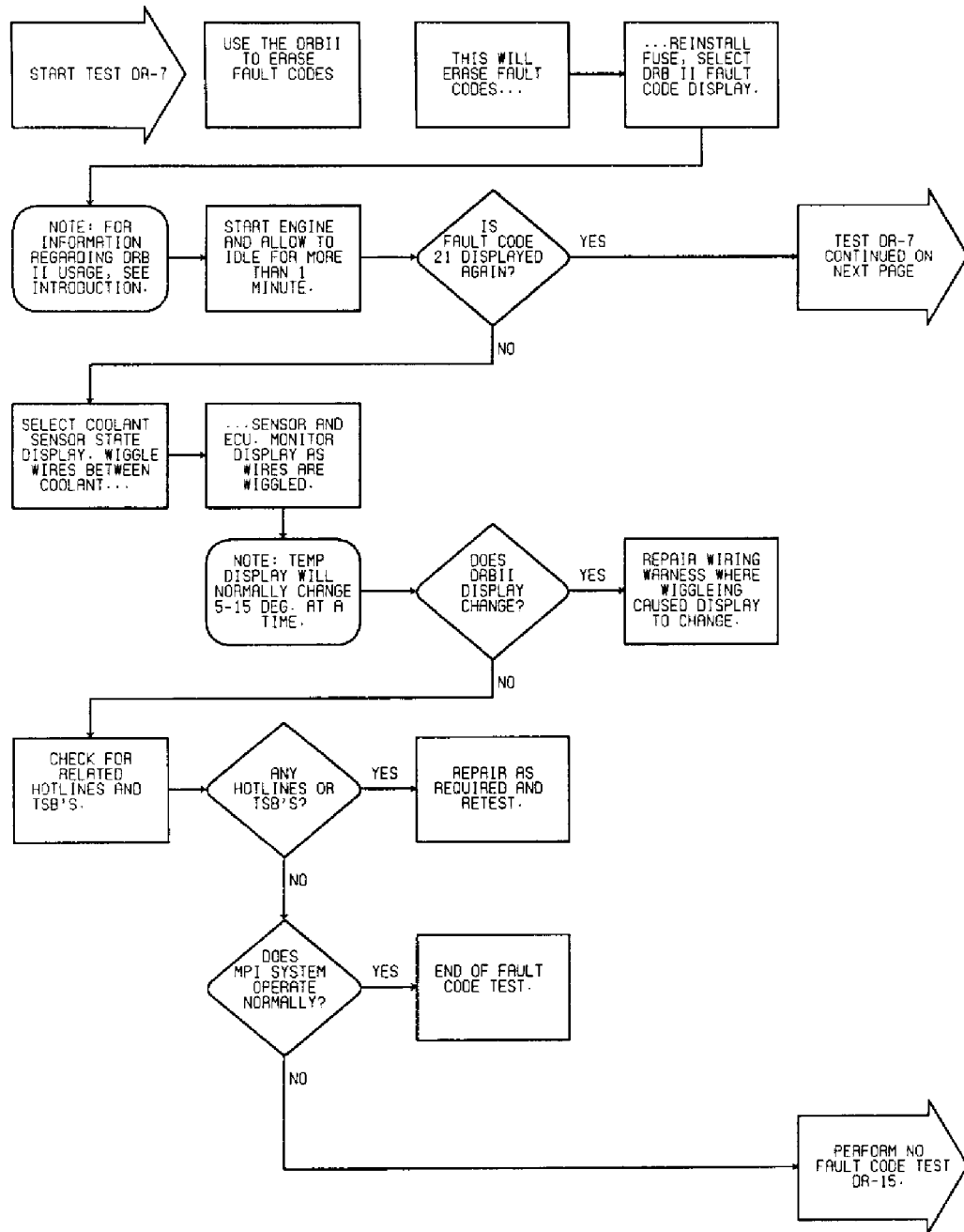

Fig. 41: DR-7 Test Flow Chart (1 Of 2)
Testing Coolant Sensor

G - TESTS W/CODES

Article Text (p. 43)

1992 Dodge Colt

For a a a a

Copyright © 1998 Mitchell Repair Information Company, LLC

Saturday, April 27, 2002 05:50PM

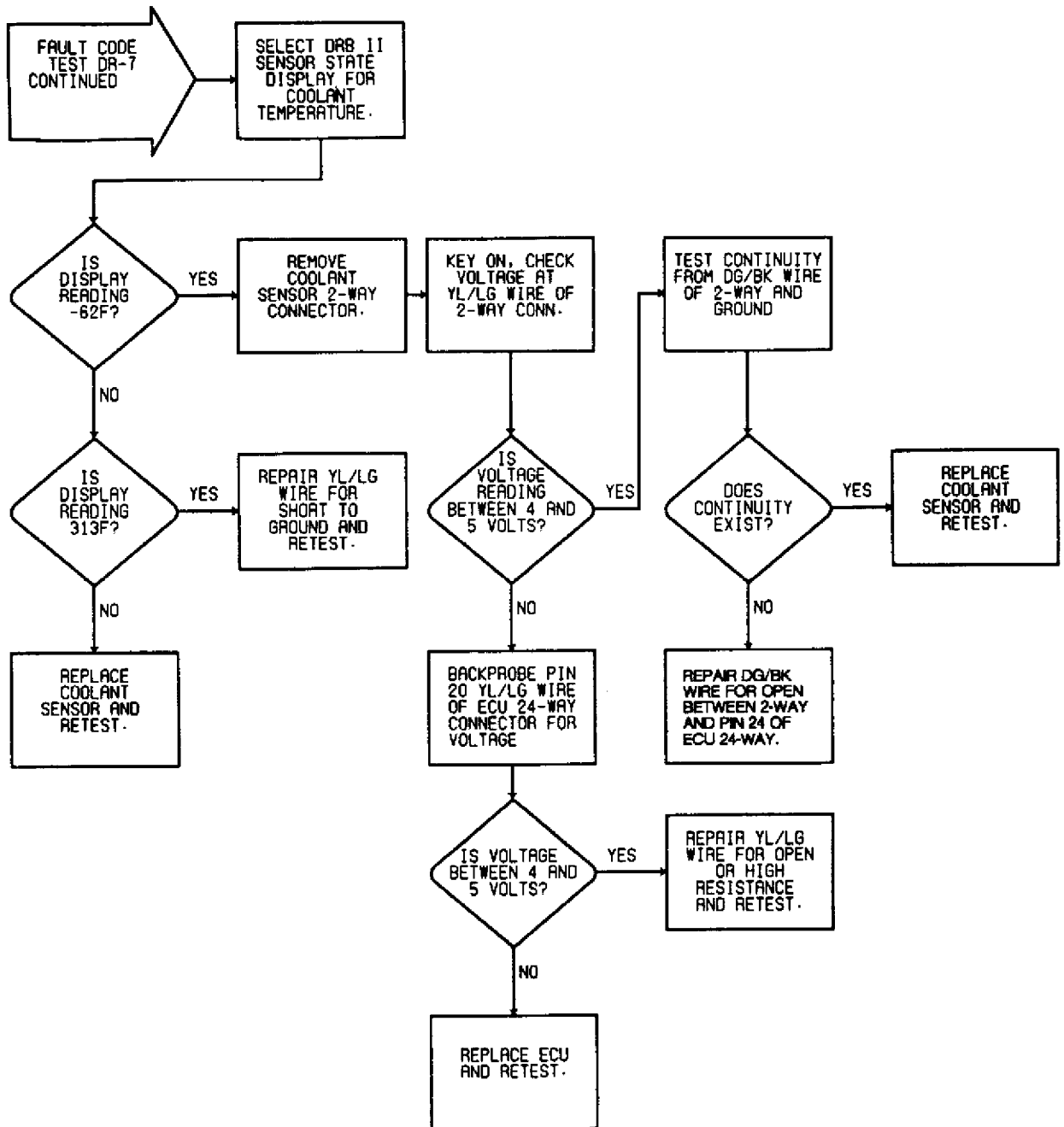

Fig. 42: DR-7 Test Flow Chart (2 Of 2)
Testing Coolant Sensor

DR-8: TESTING DIAGNOSTIC CONNECTOR

G - TESTS W/CODES

Article Text (p. 44)

1992 Dodge Colt

For a a a a

Copyright © 1998 Mitchell Repair Information Company, LLC

Saturday, April 27, 2002 05:50PM

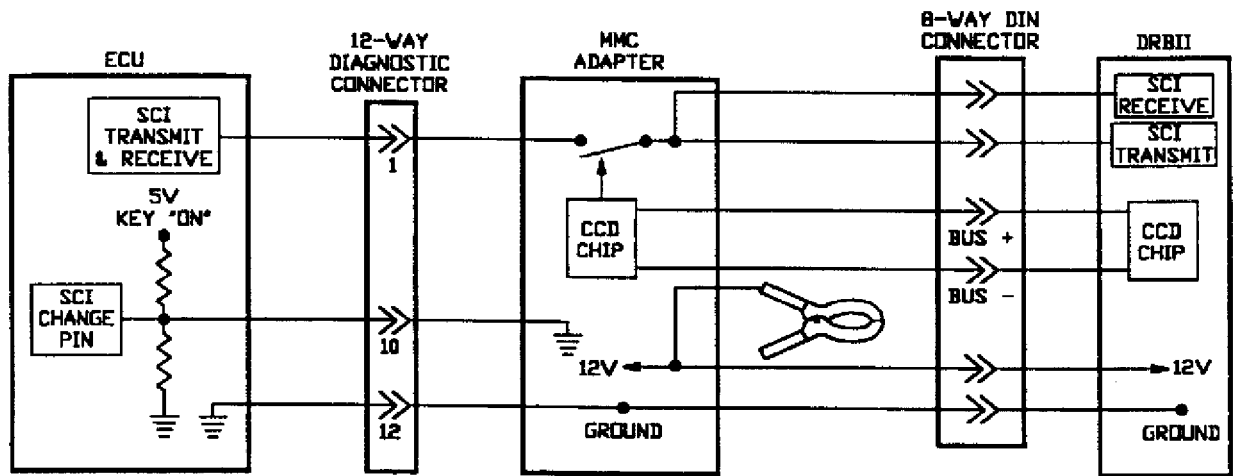

Fig. 43: DR-8 Test Schematic
Testing Diagnostic Connector

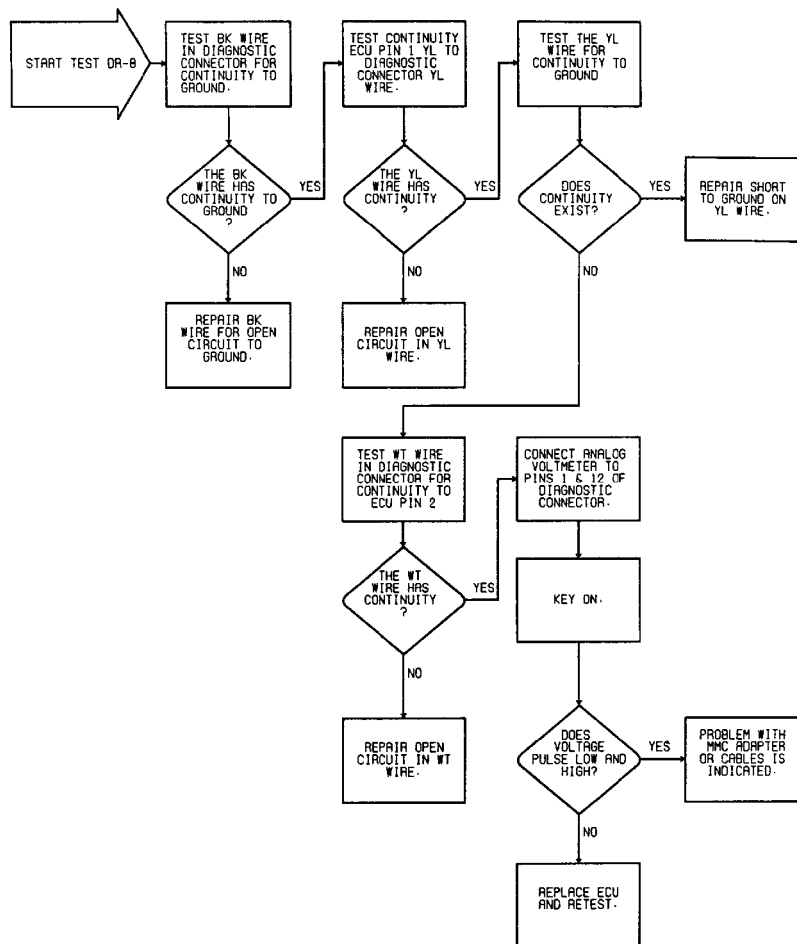

Fig. 44: DR-8 Test Flow Chart
Testing Diagnostic Connector

G - TESTS W/CODES

Article Text (p. 45)

1992 Dodge Colt

For a a a a

Copyright © 1998 Mitchell Repair Information Company, LLC

Saturday, April 27, 2002 05:50PM

DR-9: TESTING TOP DEAD CENTER SENSOR CIRCUIT

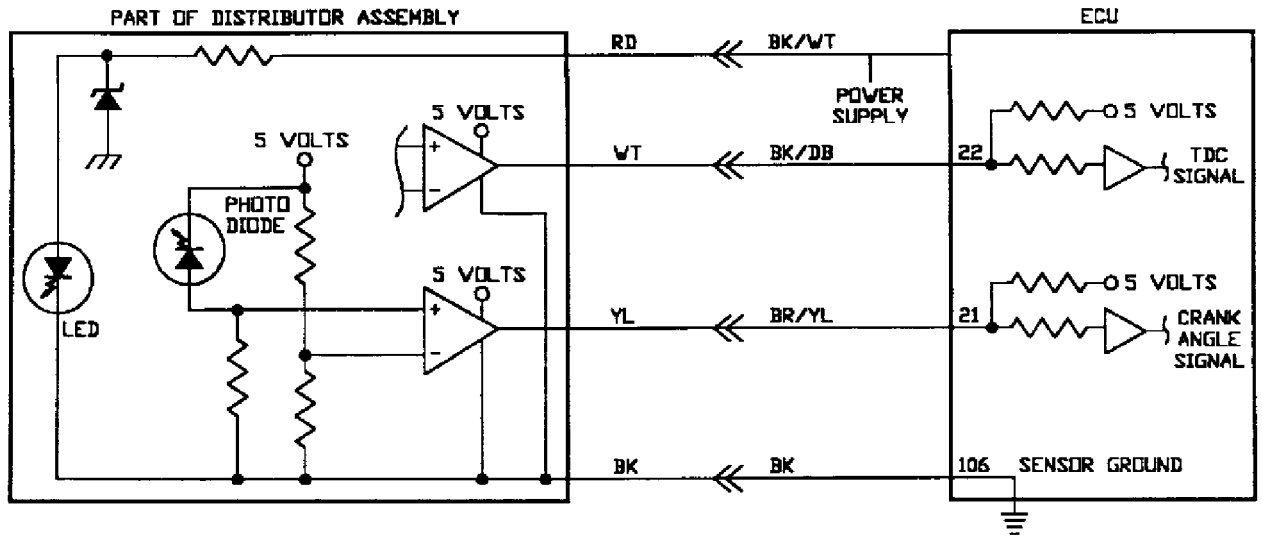

Fig. 45: DR-9 Test Schematic
Testing Top Dead Center Sensor Circuit

G - TESTS W/CODES

Article Text (p. 46)

1992 Dodge Colt

For a a a a

Copyright © 1998 Mitchell Repair Information Company, LLC

Saturday, April 27, 2002 05:50PM

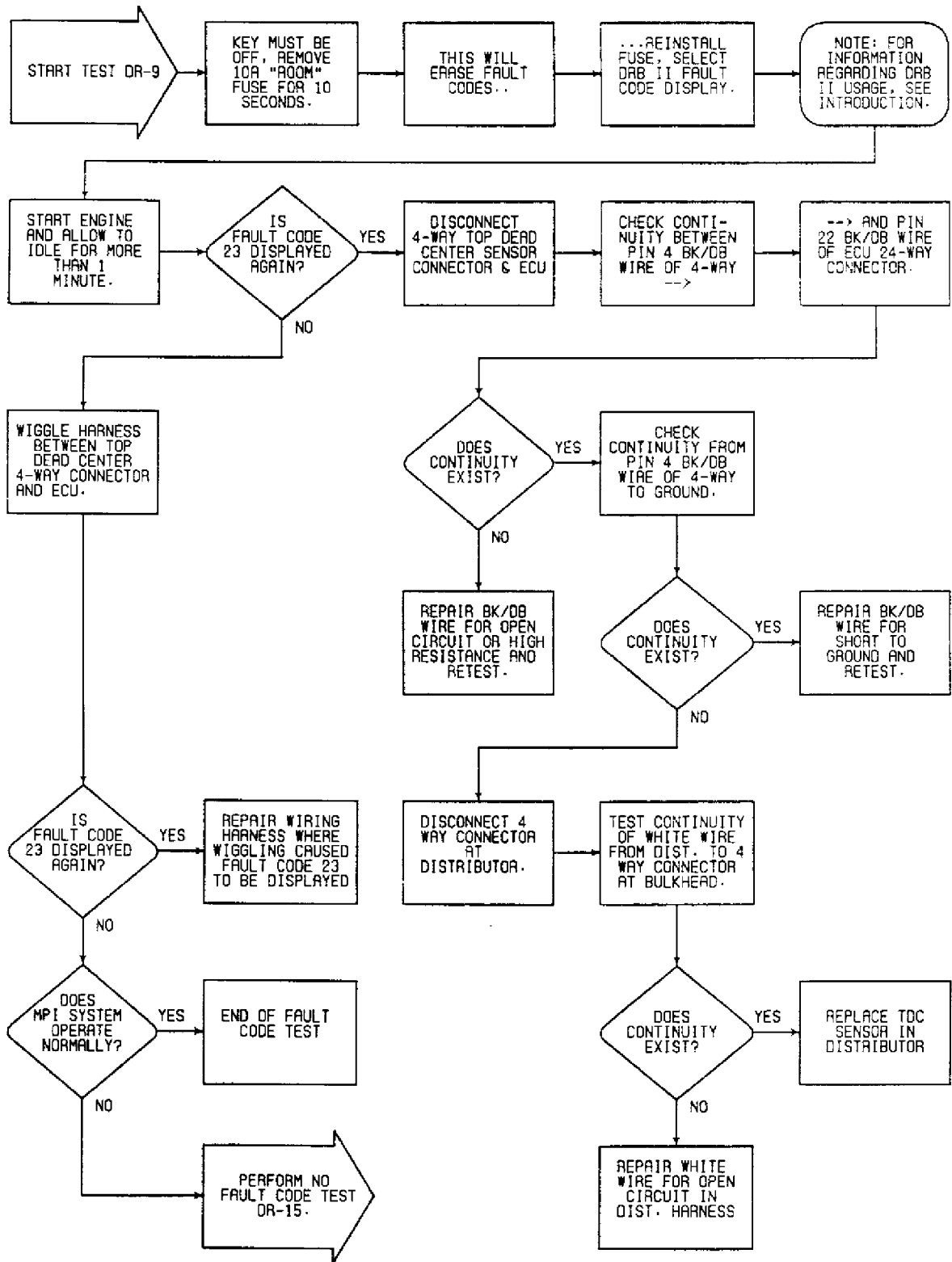

Fig. 46: DR-9 Test Flow Chart
Testing Top Dead Center Sensor Circuit

G - TESTS W/CODES

Article Text (p. 47)

1992 Dodge Colt

For a a a a

Copyright © 1998 Mitchell Repair Information Company, LLC

Saturday, April 27, 2002 05:50PM

DR-10: TESTING SPEED SENSOR CIRCUIT

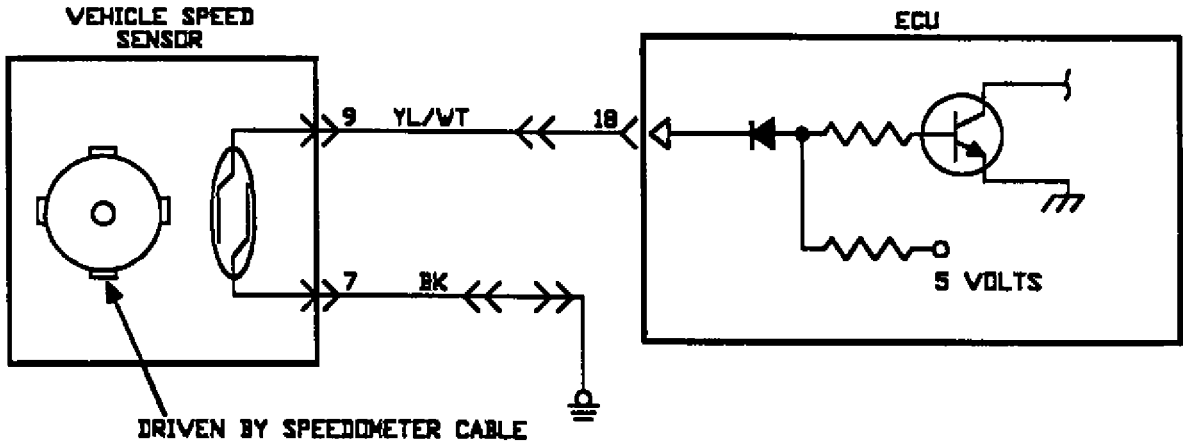

Fig. 47: DR-10 Test Schematic
Testing Speed Sensor Circuit

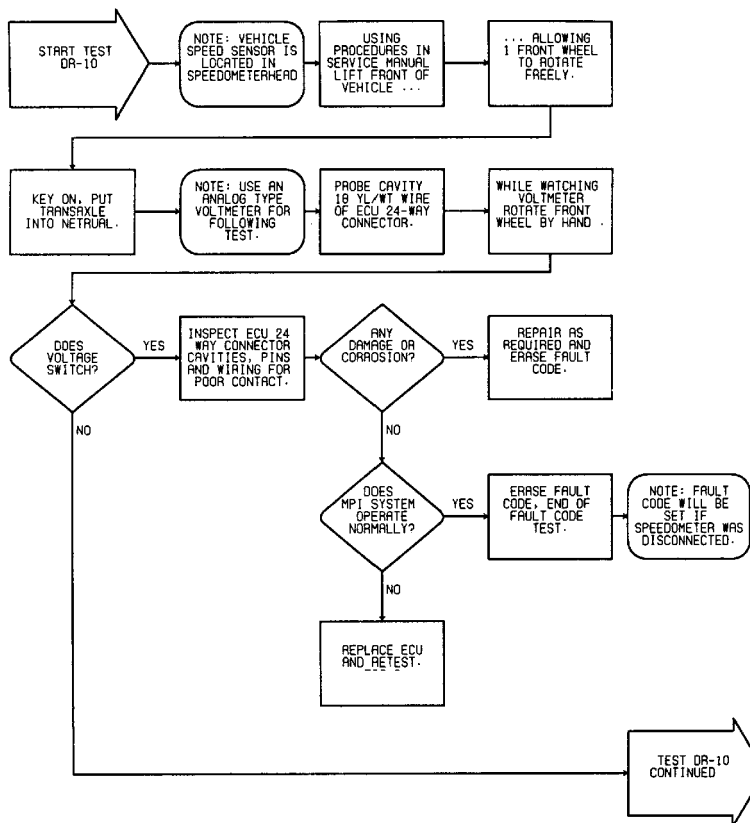

Fig. 48: DR-10 Test Flow Chart (1 Of 2)
Testing Speed Sensor Circuit

G - TESTS W/CODES

Article Text (p. 48)

1992 Dodge Colt

For a a a a

Copyright © 1998 Mitchell Repair Information Company, LLC

Saturday, April 27, 2002 05:50PM

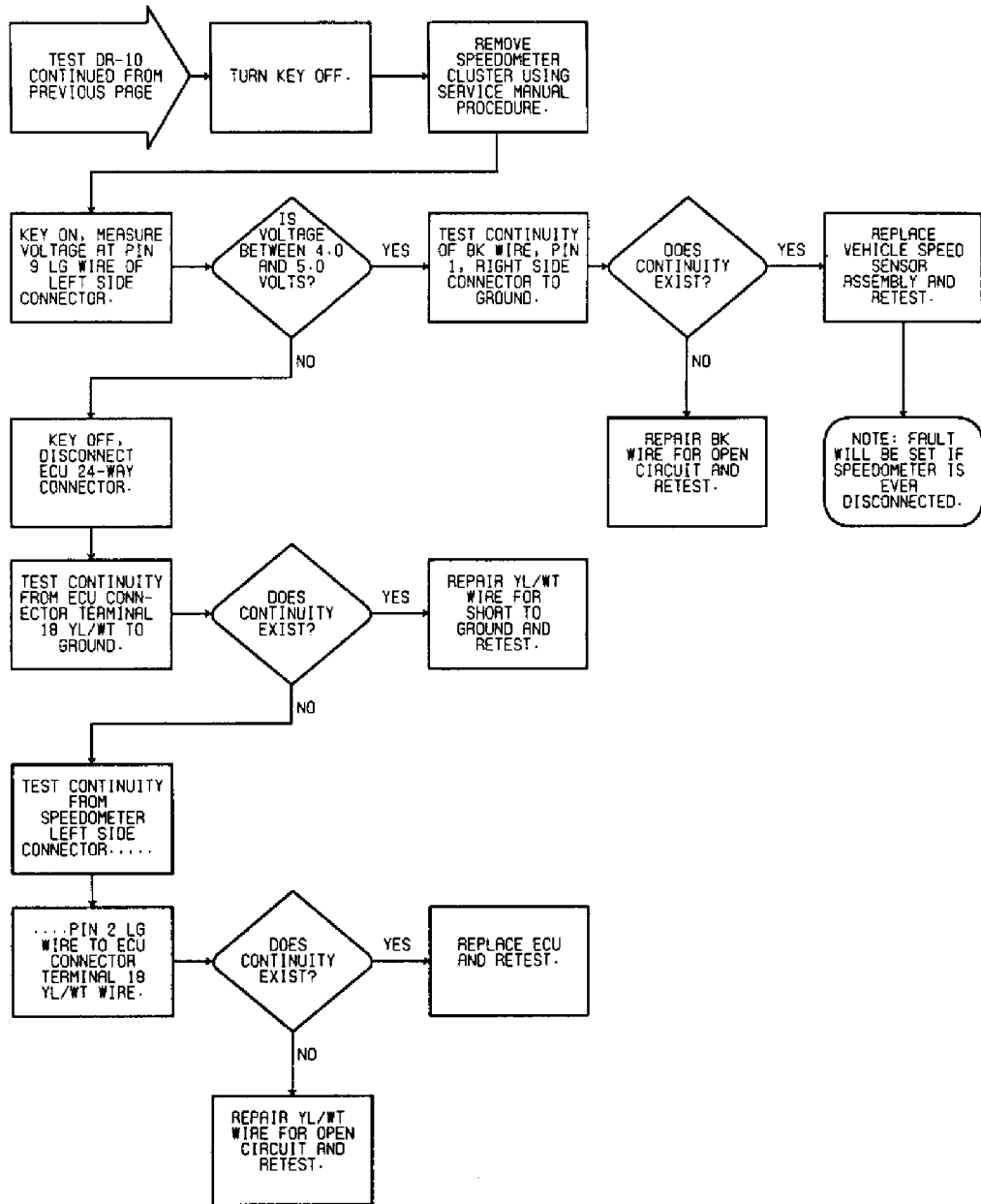

Fig. 49: DR-10 Test Flow Chart (2 Of 2)
Testing Speed Sensor Circuit

DR-11: TESTING BAROMETRIC PRESSURE SENSOR

G - TESTS W/CODES

Article Text (p. 49)

1992 Dodge Colt

For a a a a

Copyright © 1998 Mitchell Repair Information Company, LLC
Saturday, April 27, 2002 05:50PM

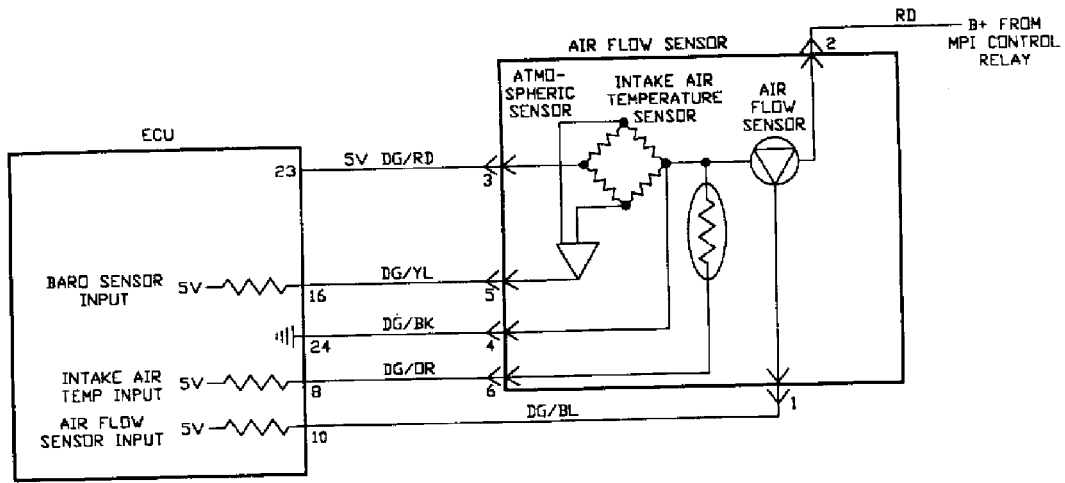

Fig. 50: DR-11 Test Schematic
Testing Barometric Pressure Sensor

G - TESTS W/CODES

Article Text (p. 50)

1992 Dodge Colt

For a a a a

Copyright © 1998 Mitchell Repair Information Company, LLC

Saturday, April 27, 2002 05:50PM

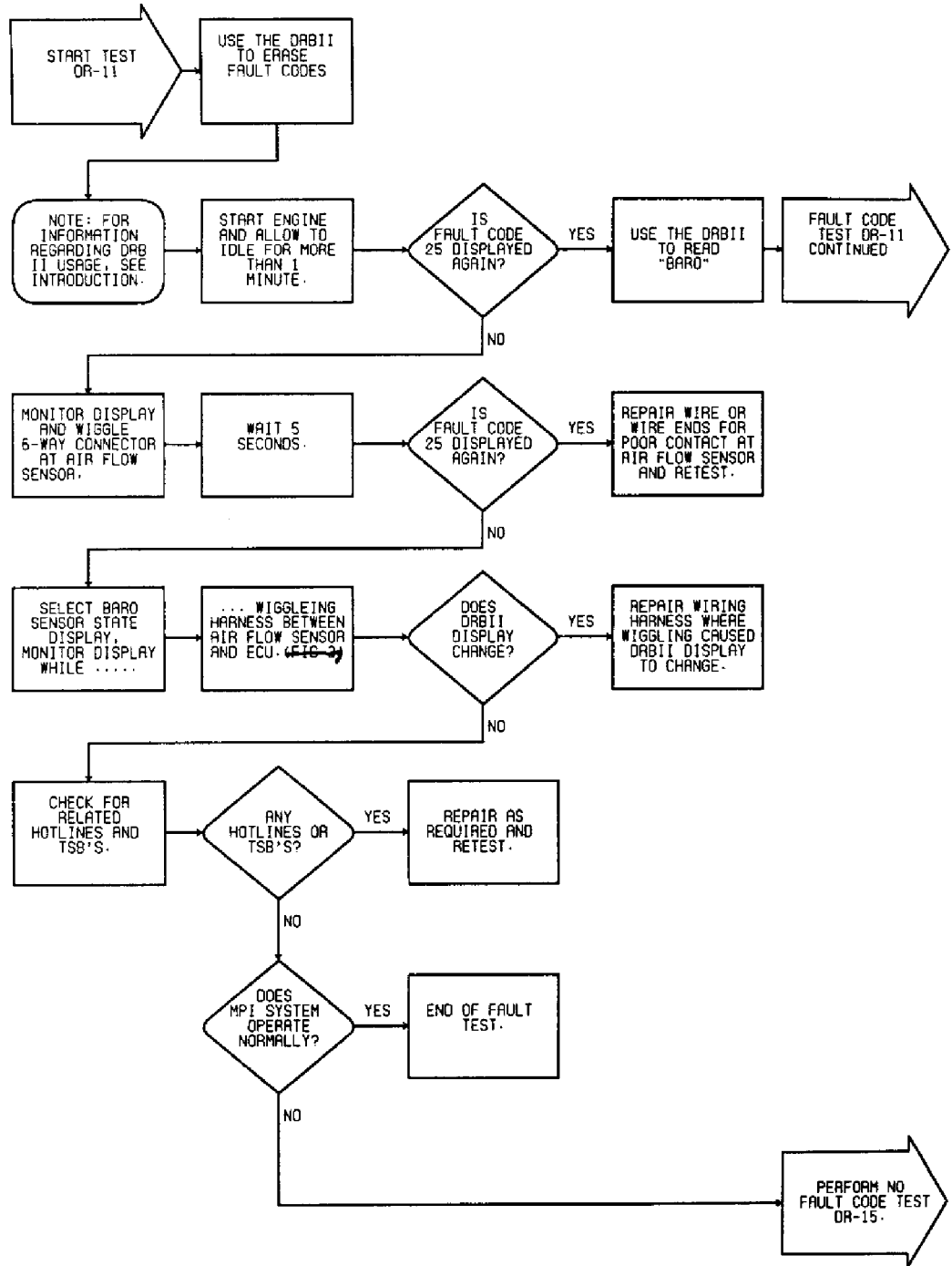

Fig. 51: DR-11 Test Flow Chart (1 Of 2)
Testing Barometric Pressure Sensor

G - TESTS W/CODES

Article Text (p. 51)

1992 Dodge Colt

For a a a a

Copyright © 1998 Mitchell Repair Information Company, LLC

Saturday, April 27, 2002 05:50PM

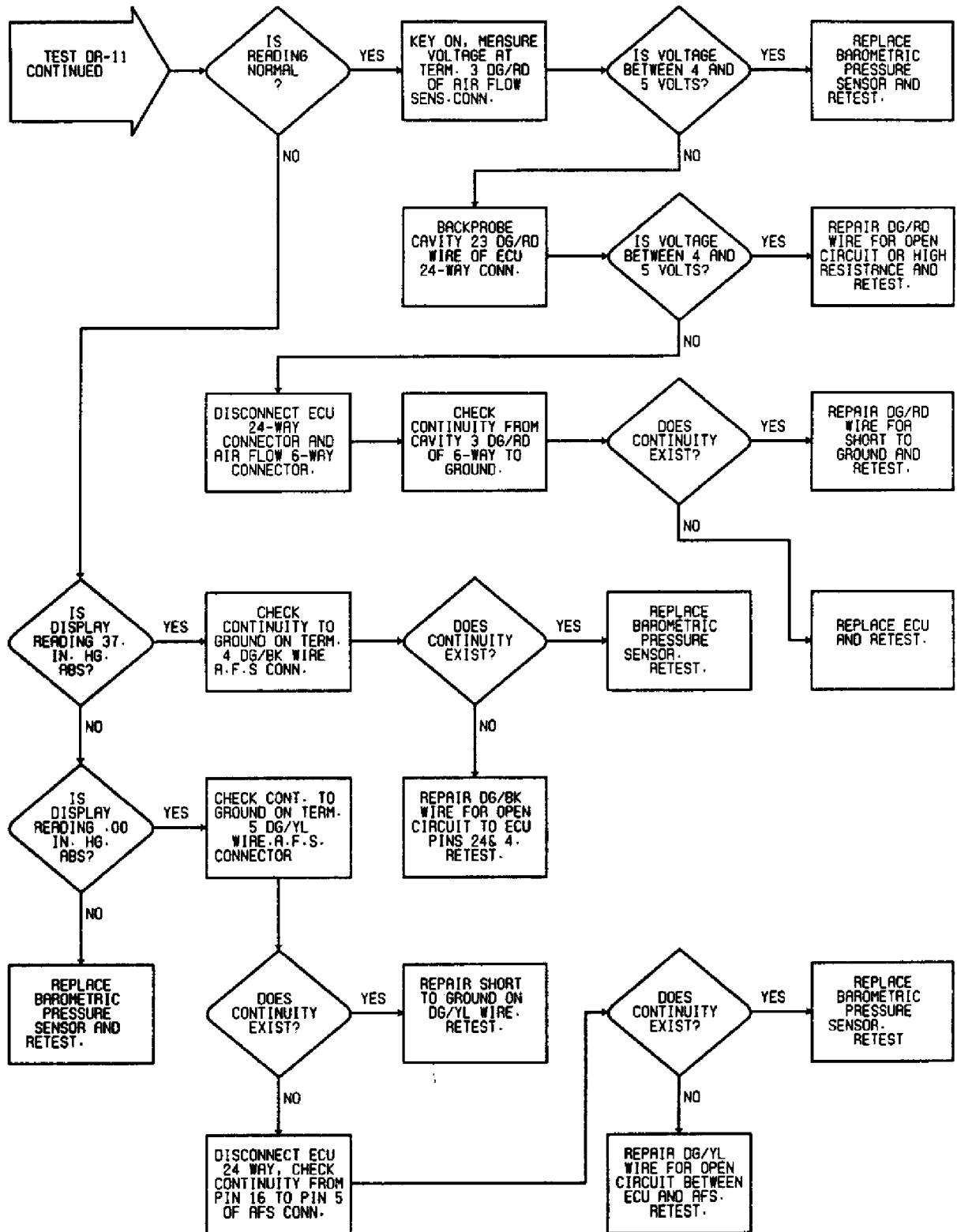

Fig. 52: DR-11 Test Flow Chart (2 Of 2)
Testing Barometric Pressure Sensor

G - TESTS W/CODES

Article Text (p. 52)

1992 Dodge Colt

For a a a a

Copyright © 1998 Mitchell Repair Information Company, LLC
Saturday, April 27, 2002 05:50PM

DR-12: TESTING INJECTOR CIRCUIT

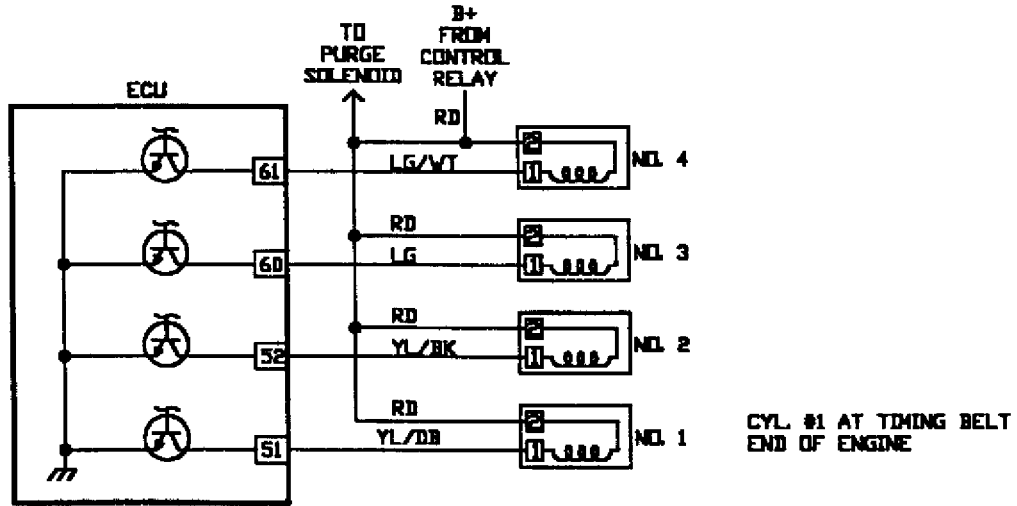

Fig. 53: DR-12 Test Schematic
Testing Injector Circuit

G - TESTS W/CODES

Article Text (p. 53)

1992 Dodge Colt

For a a a a

Copyright © 1998 Mitchell Repair Information Company, LLC

Saturday, April 27, 2002 05:50PM

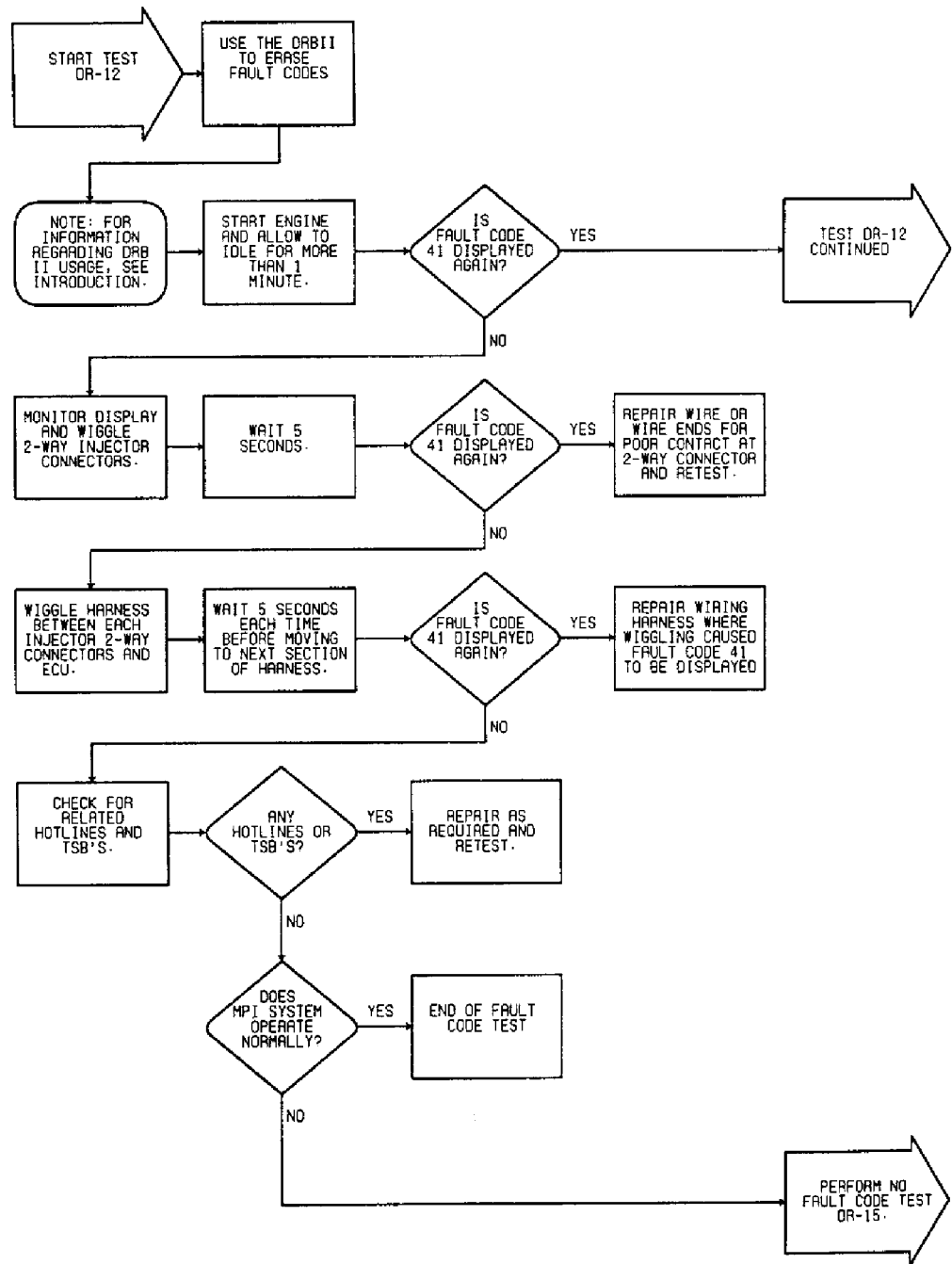

Fig. 54: DR-12 Test Flow Chart (1 Of 2)
Testing Injector Circuit

G - TESTS W/CODES

Article Text (p. 54)

1992 Dodge Colt

For a a a a

Copyright © 1998 Mitchell Repair Information Company, LLC

Saturday, April 27, 2002 05:50PM

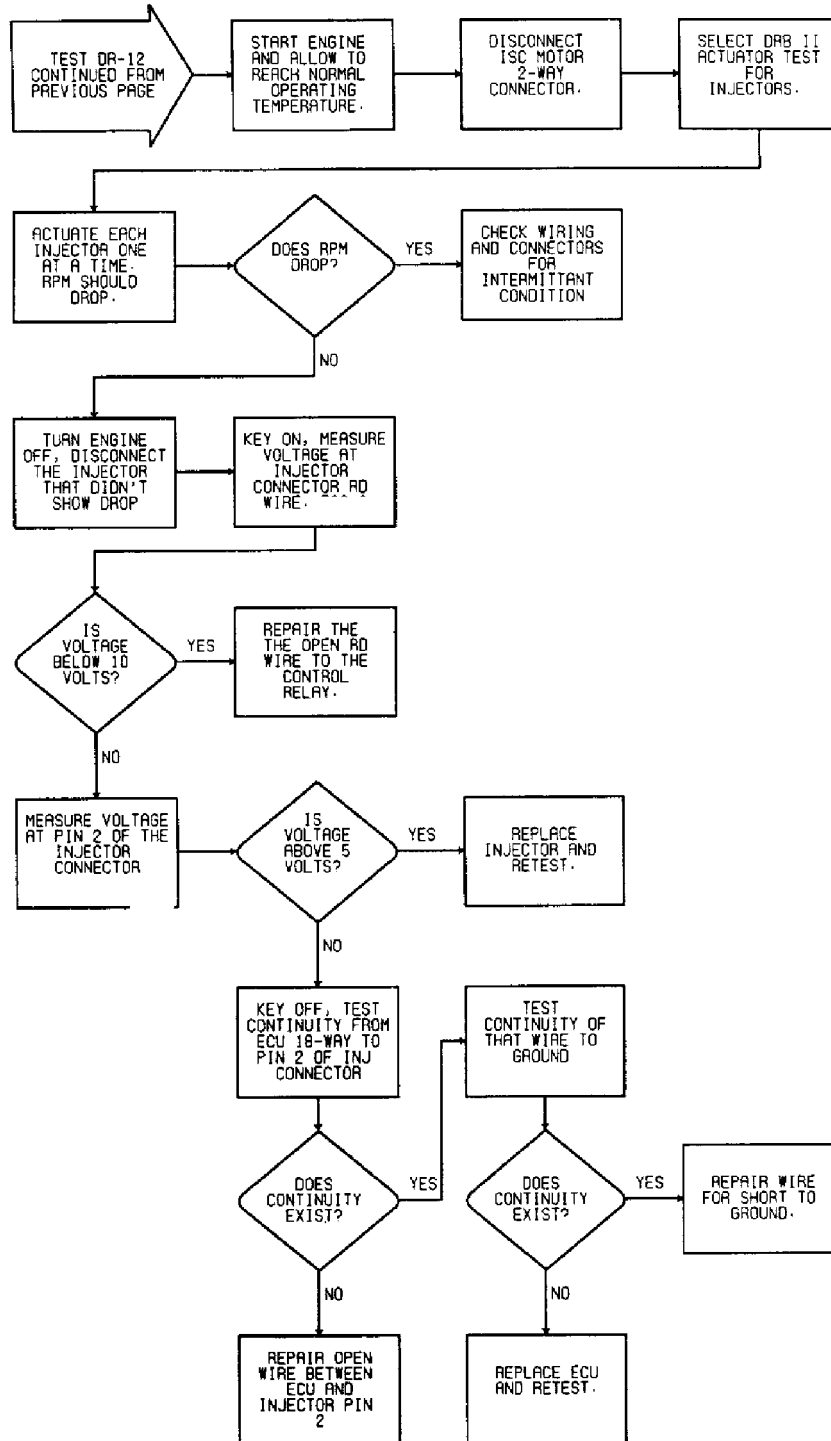

Fig. 55: DR-12 Test Flow Chart (2 Of 2)
Testing Injector Circuit

G - TESTS W/CODES

Article Text (p. 55)

1992 Dodge Colt

For a a a a

Copyright © 1998 Mitchell Repair Information Company, LLC

Saturday, April 27, 2002 05:50PM

DR-13: TESTING FUEL PUMP CIRCUIT

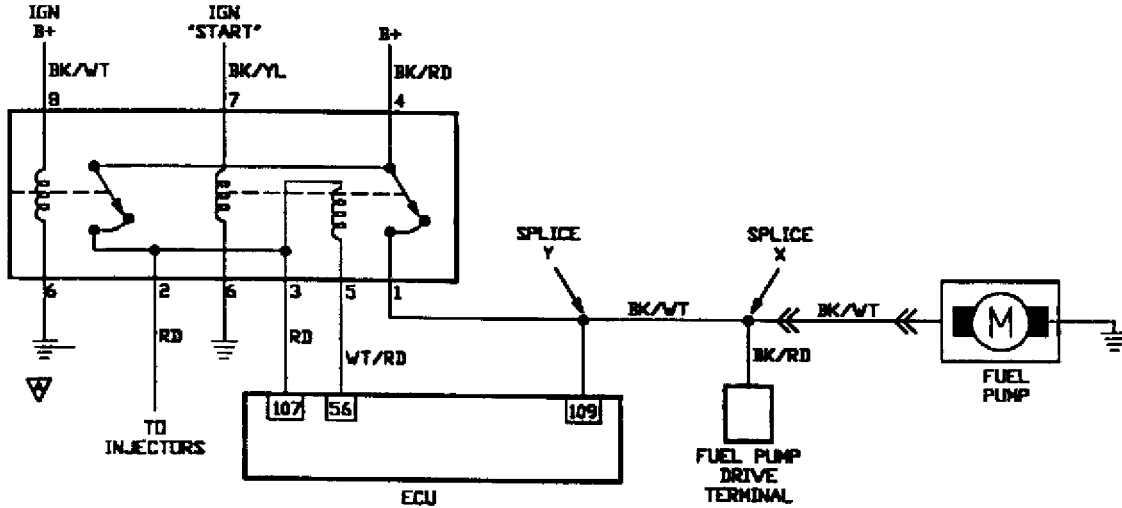

Fig. 56: DR-13 Test Schematic Testing Fuel Pump Circuit

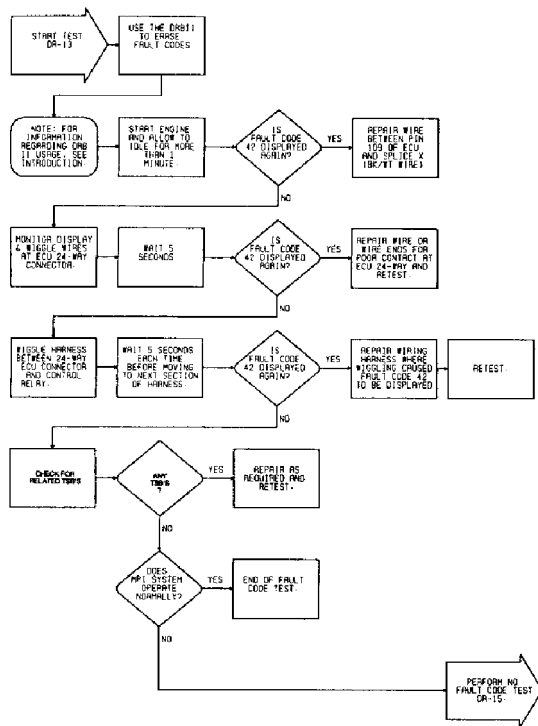

Fig. 57: DR-13 Test Flow Chart Testing Fuel Pump Circuit

G - TESTS W/CODES

Article Text (p. 56)

1992 Dodge Colt

For a a a a

Copyright © 1998 Mitchell Repair Information Company, LLC

Saturday, April 27, 2002 05:50PM

DR-14: TESTING EGR TEMPERATURE SENSOR CIRCUIT

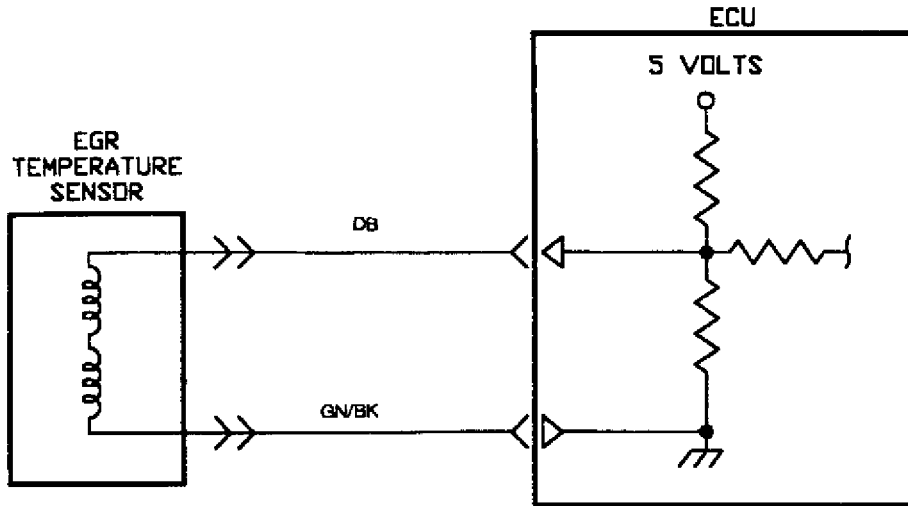

Fig. 58: DR-14 Test Schematic
Testing EGR Temperature Sensor Circuit

G - TESTS W/CODES

Article Text (p. 57)

1992 Dodge Colt

For a a a a

Copyright © 1998 Mitchell Repair Information Company, LLC

Saturday, April 27, 2002 05:50PM

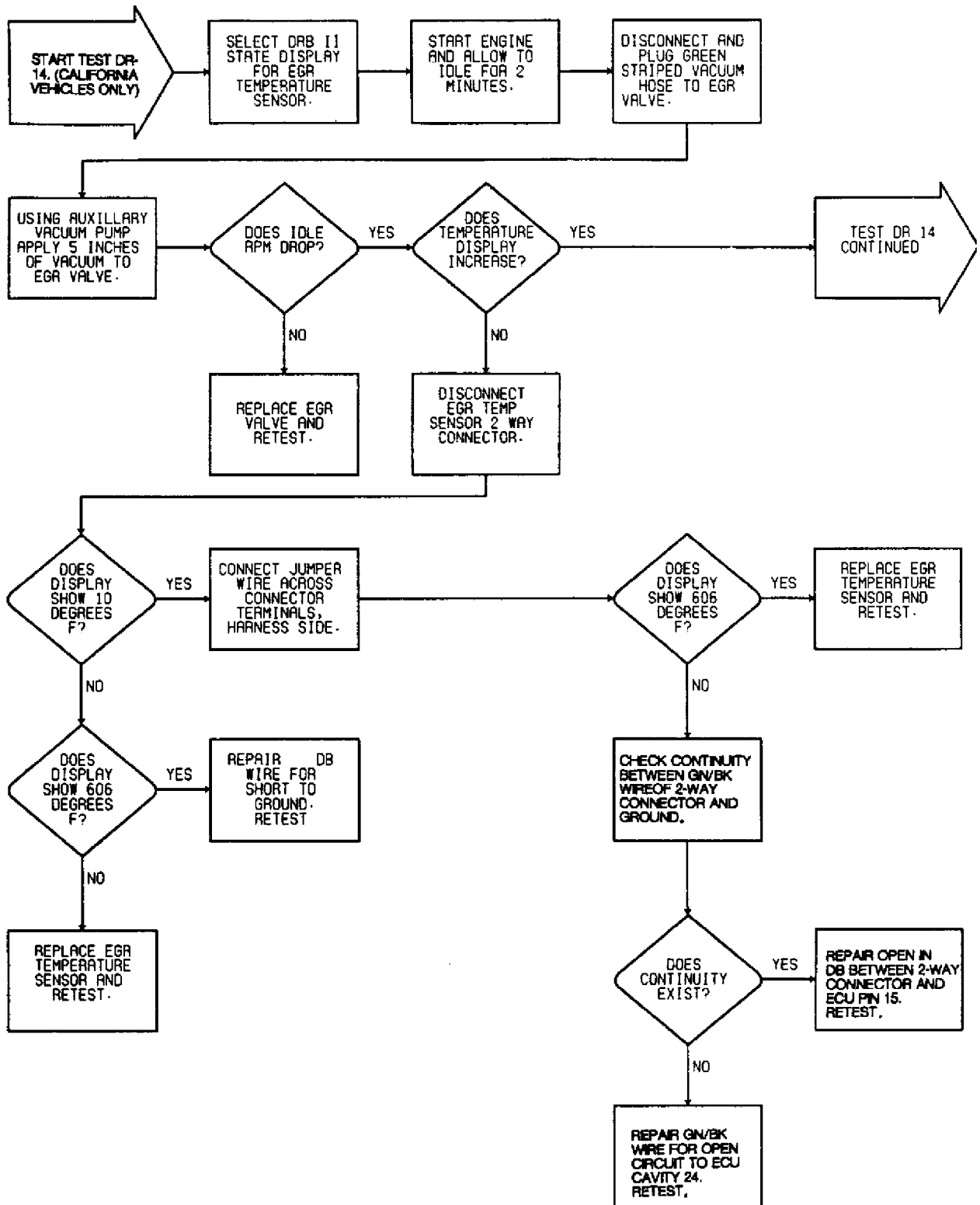

Fig. 59: DR-14 Test Flow Chart (1 Of 3)
Testing EGR Temperature Sensor Circuit

G - TESTS W/CODES

Article Text (p. 58)

1992 Dodge Colt

For a a a a

Copyright © 1998 Mitchell Repair Information Company, LLC

Saturday, April 27, 2002 05:50PM

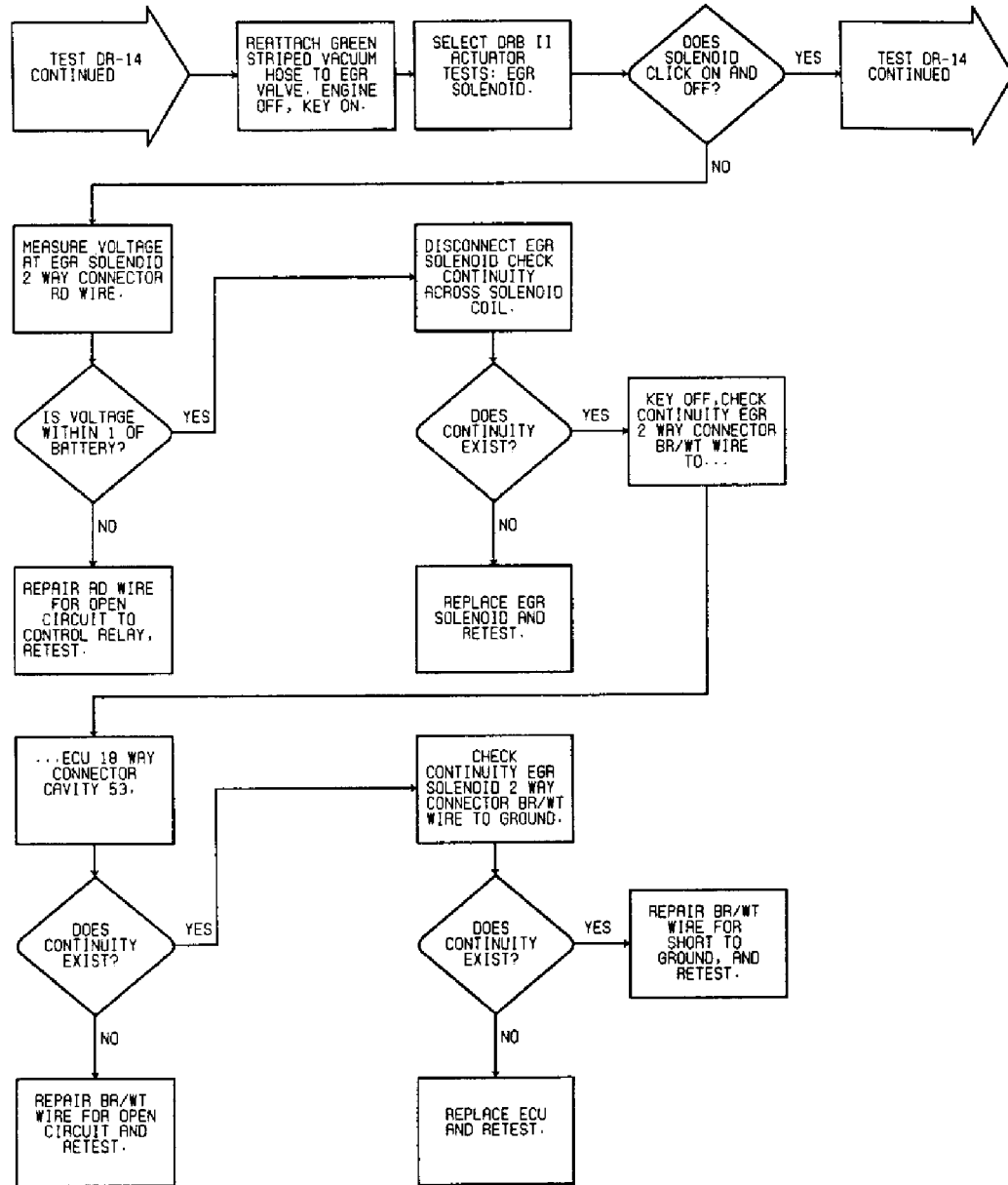

Fig. 60: DR-14 Test Flow Chart (2 Of 3)
Testing EGR Temperature Sensor Circuit

G - TESTS W/CODES

Article Text (p. 59)

1992 Dodge Colt

For a a a a

Copyright © 1998 Mitchell Repair Information Company, LLC

Saturday, April 27, 2002 05:50PM

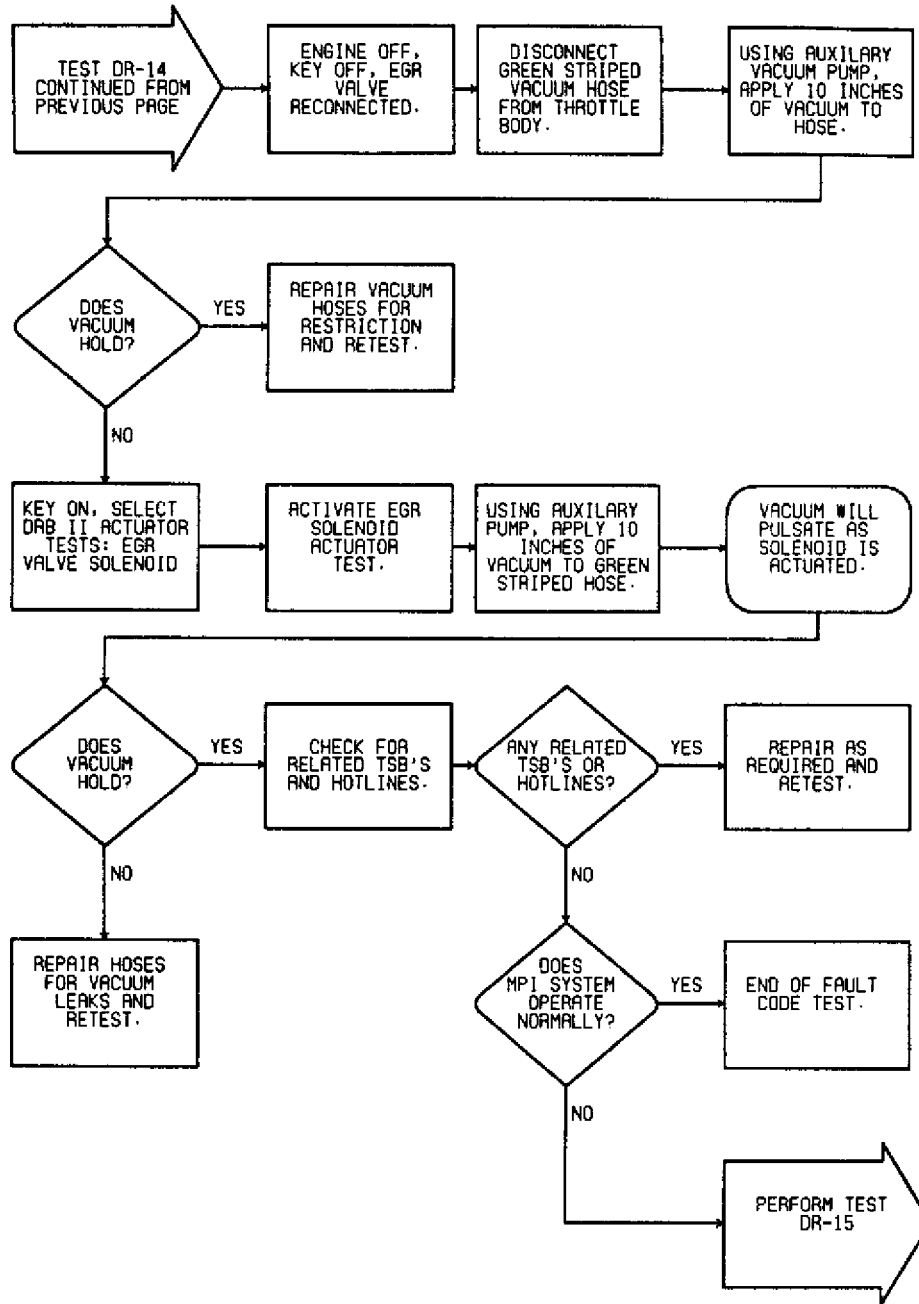

Fig. 61: DR-14 Test Flow Chart (3 Of 3)
Testing EGR Temperature Sensor Circuit

DR-15: NO FAULT CODE TESTING

G - TESTS W/CODES

Article Text (p. 60)

1992 Dodge Colt

For a a a a

Copyright © 1998 Mitchell Repair Information Company, LLC

Saturday, April 27, 2002 05:50PM

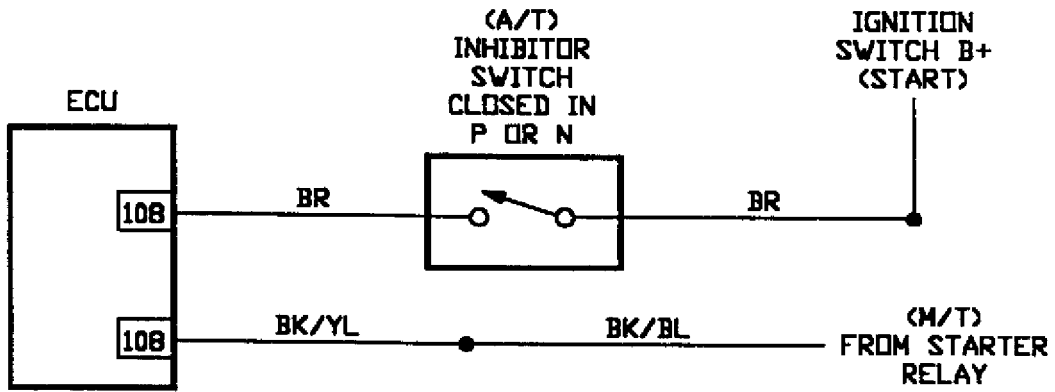

Fig. 62: DR-15 Test Schematic (1 Of 2)
No Fault Code Testing

G - TESTS W/CODES

Article Text (p. 61)

1992 Dodge Colt

For a a a a

Copyright © 1998 Mitchell Repair Information Company, LLC

Saturday, April 27, 2002 05:50PM

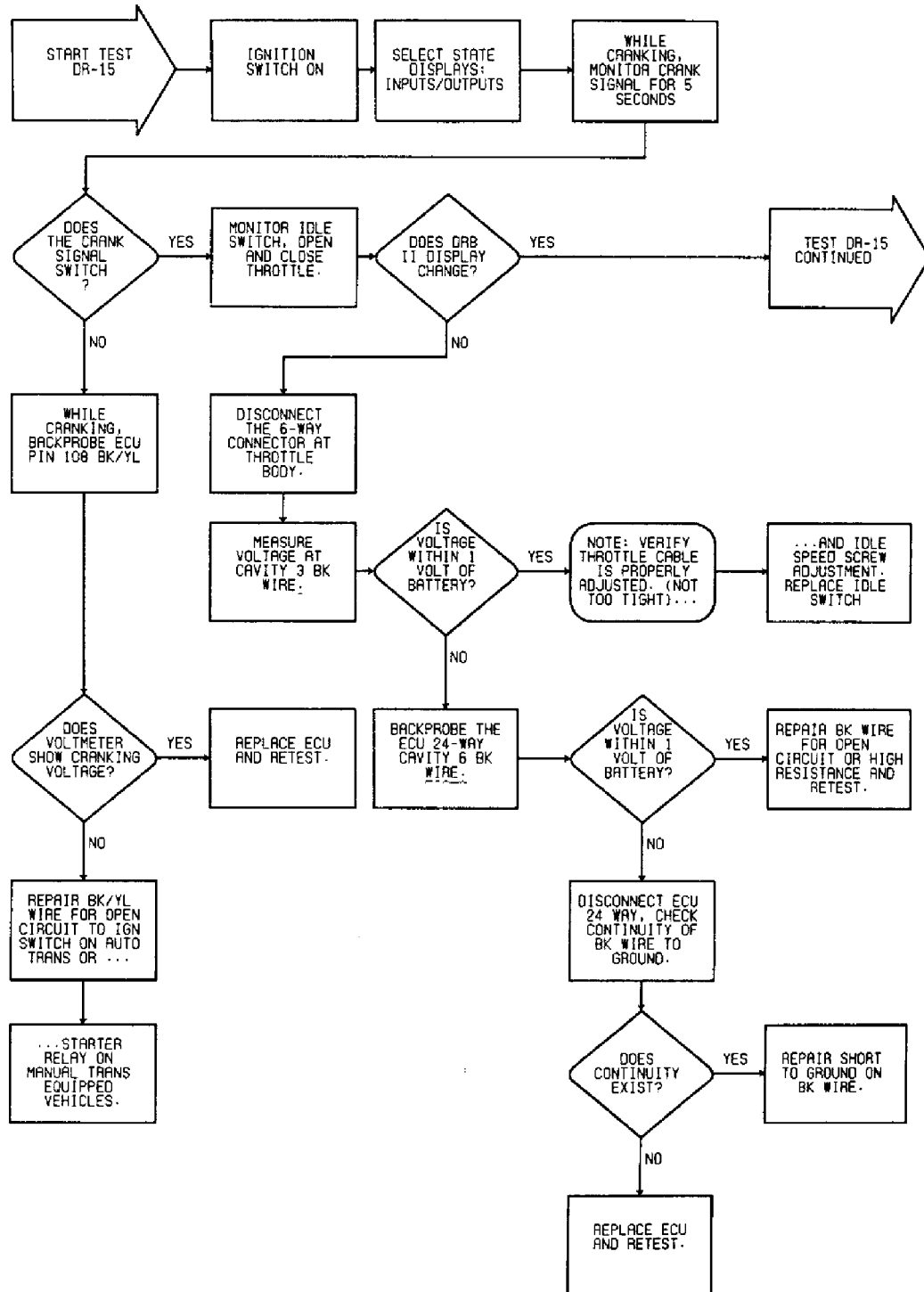

Fig. 63: DR-15 Test Flow Chart (1 Of 2)
No Fault Code Testing

G - TESTS W/CODES

Article Text (p. 62)

1992 Dodge Colt

For a a a a

Copyright © 1998 Mitchell Repair Information Company, LLC

Saturday, April 27, 2002 05:50PM

AIR CONDITIONING INPUT CIRCUIT

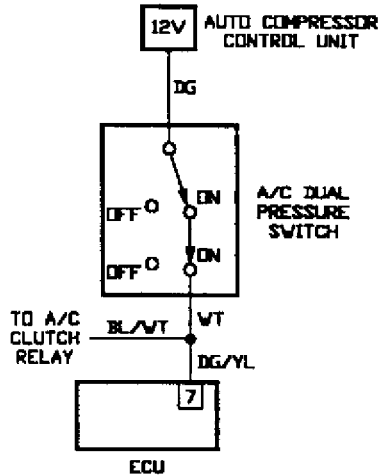

INHIBITOR SWITCH CIRCUIT

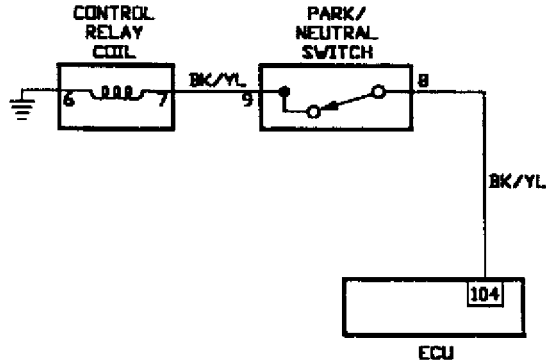

Fig. 64: DR-15 Test Schematic (2 Of 2)
No Fault Code Testing

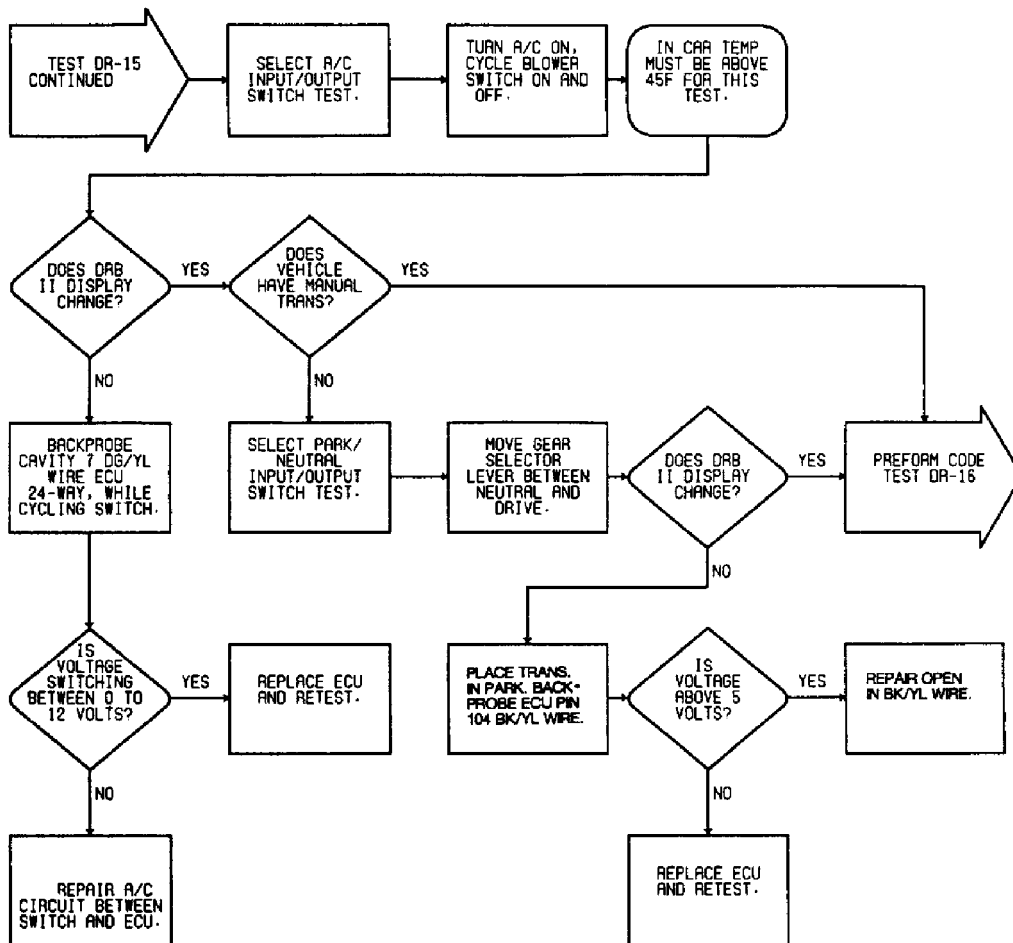

Fig. 65: DR-15 Test Flow Chart (2 Of 2)
No Fault Code Testing

G - TESTS W/CODES

Article Text (p. 63)

1992 Dodge Colt

For a a a a

Copyright © 1998 Mitchell Repair Information Company, LLC
Saturday, April 27, 2002 05:50PM

DR-16: NO FAULT CODE SENSOR TEST

DR-16 EGR TEMP SENSOR TEST TABLE

DRB-II

EGR Temp. Display

Engine Condition

160°F	Hot Idle (198°F Coolant)
350°F	25 MPH at 3500 RPM
311°F	55 MPH at 3500 RPM

G - TESTS W/CODES

Article Text (p. 64)

1992 Dodge Colt

For a a a a

Copyright © 1998 Mitchell Repair Information Company, LLC

Saturday, April 27, 2002 05:50PM

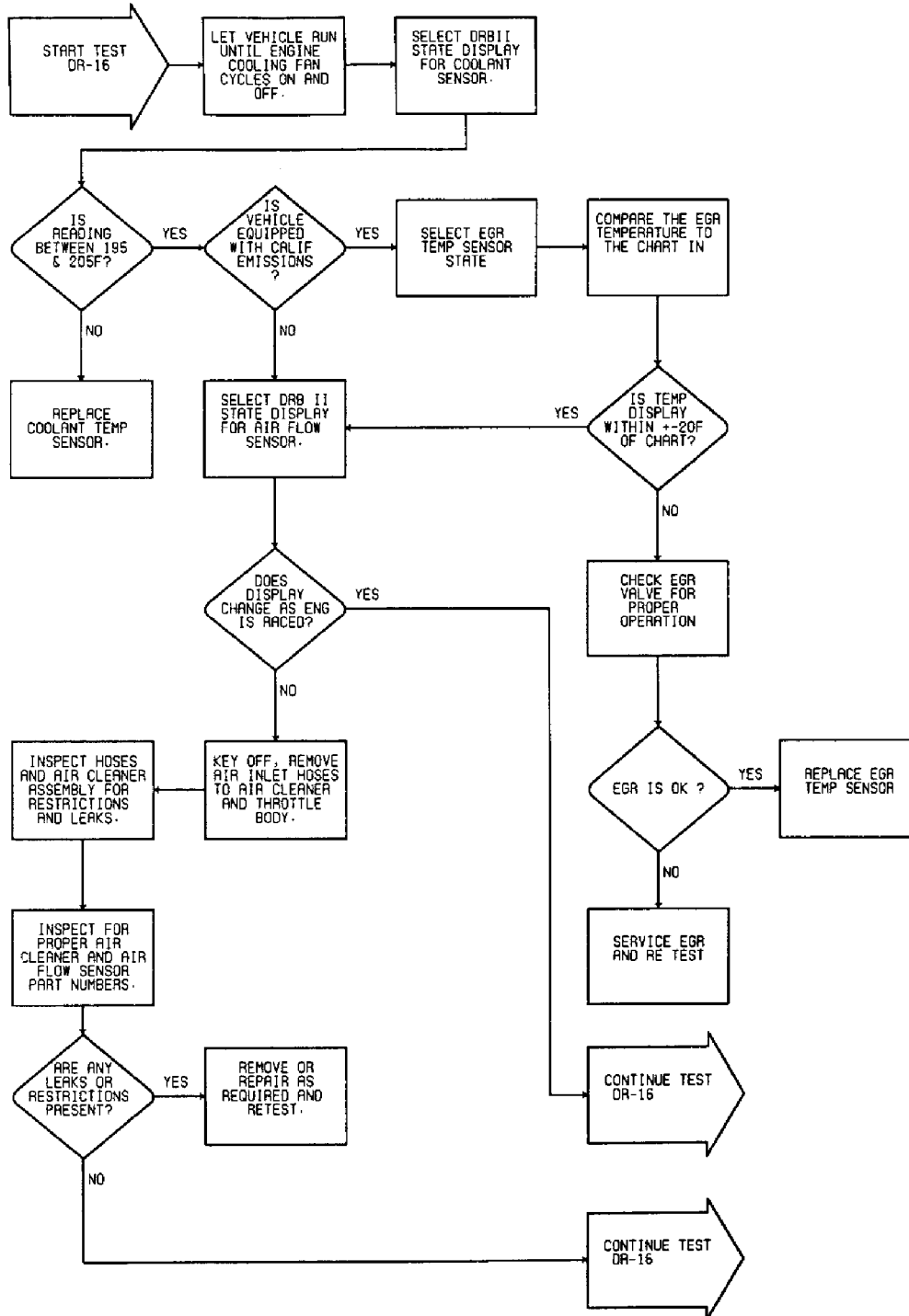

Fig. 66: DR-16 Test Flow Chart (1 Of 5)
No Fault Code Sensor Test

G - TESTS W/CODES

Article Text (p. 65)

1992 Dodge Colt

For a a a a

Copyright © 1998 Mitchell Repair Information Company, LLC
Saturday, April 27, 2002 05:50PM

DR-16 BARO SENSOR TEST TABLE

Altitude (Ft)	DRB-II BARO Reading (in. HG)
-1000	31.01
-900	30.90
Sea Level	29.92
500	29.38
1000	28.85
1500	28.33
2000	27.82
3000	26.81
4000	25.84
6000	23.97
8000	22.22
10,000	20.57
12,000	19.02
14,000	17.57

G - TESTS W/CODES

Article Text (p. 66)

1992 Dodge Colt

For a a a a

Copyright © 1998 Mitchell Repair Information Company, LLC

Saturday, April 27, 2002 05:50PM

16

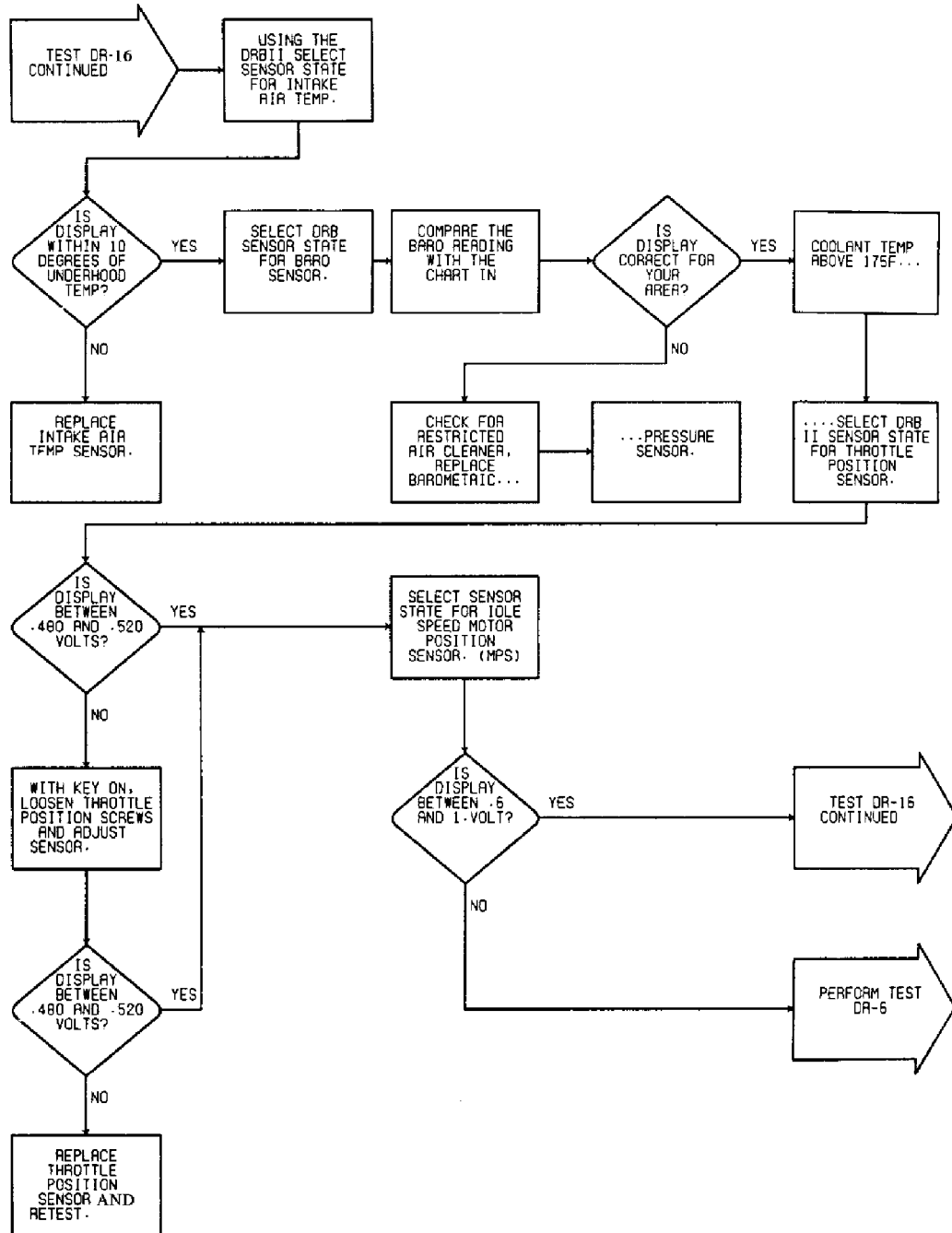

Fig. 67: DR-16 Test Flow Chart (2 Of 5)
No Fault Code Sensor Test

G - TESTS W/CODES

Article Text (p. 67)

1992 Dodge Colt

For a a a a

Copyright © 1998 Mitchell Repair Information Company, LLC

Saturday, April 27, 2002 05:50PM

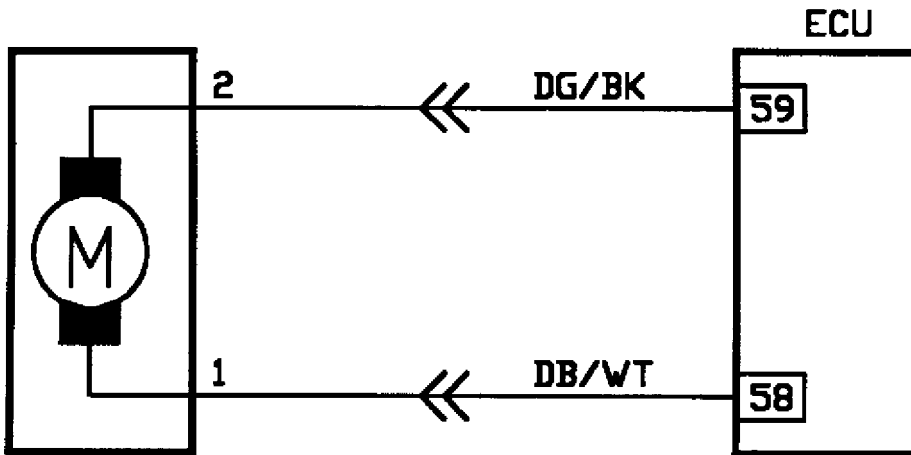
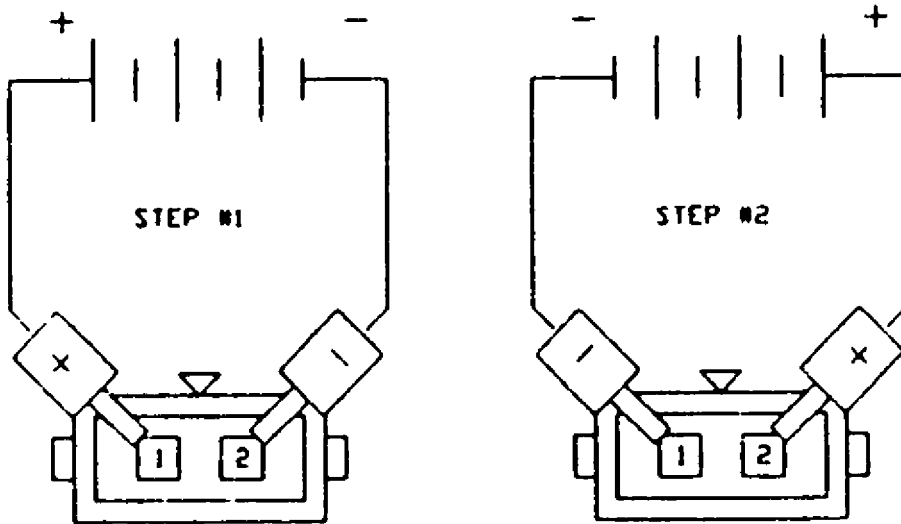

Fig. 68: DR-16 Test Schematic - ISC Motor
No Fault Code Sensor Test



TESTING ISC MOTOR

92E27163

Fig. 69: DR-16 Test - ISC Motor Test Diagram
No Fault Code Sensor Test

G - TESTS W/CODES

Article Text (p. 68)

1992 Dodge Colt

For a a a a

Copyright © 1998 Mitchell Repair Information Company, LLC

Saturday, April 27, 2002 05:50PM

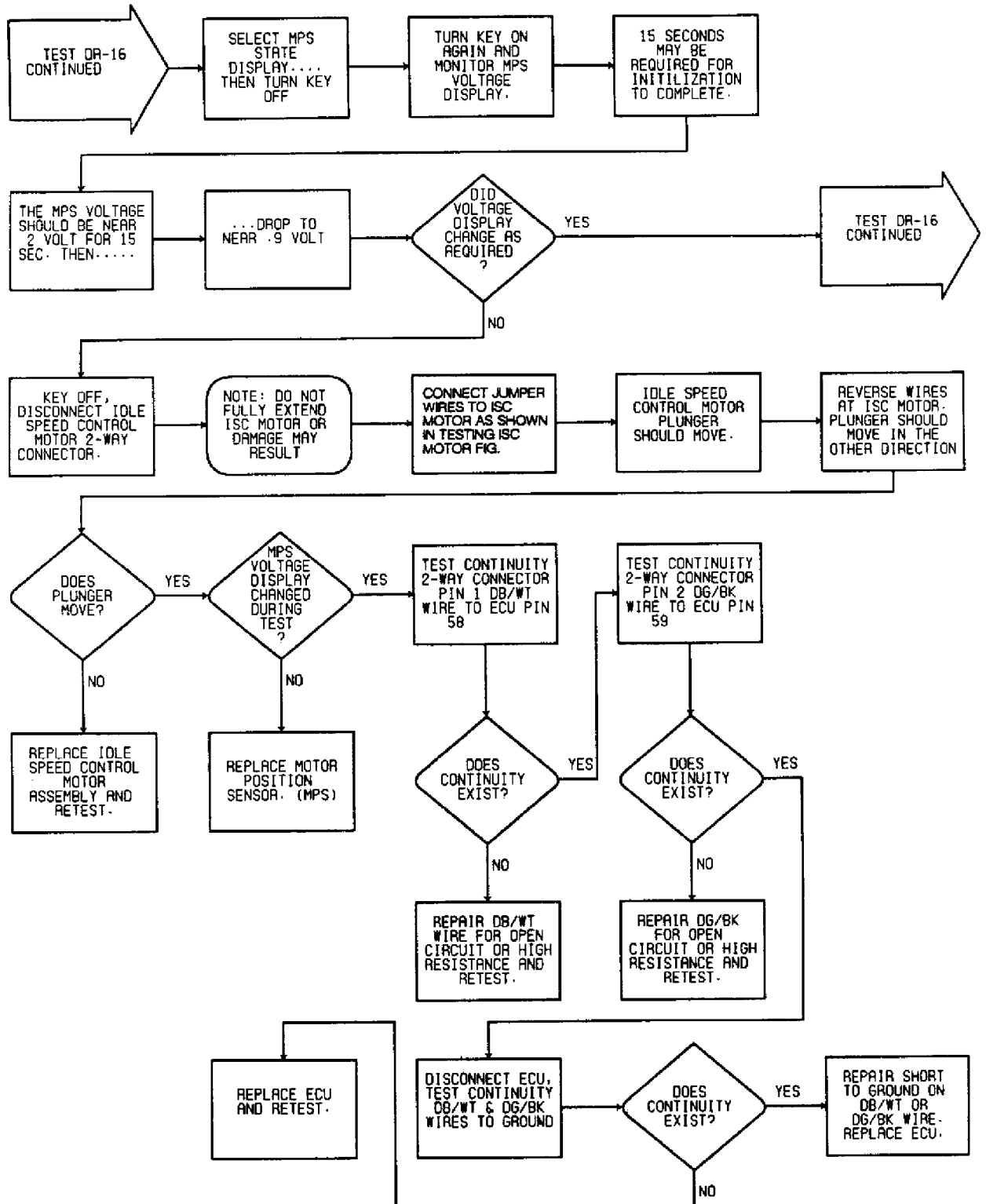

Fig. 70: DR-16 Test Flow Chart (3 Of 5)
No Fault Code Sensor Test

G - TESTS W/CODES

Article Text (p. 69)

1992 Dodge Colt

For a a a a

Copyright © 1998 Mitchell Repair Information Company, LLC

Saturday, April 27, 2002 05:50PM

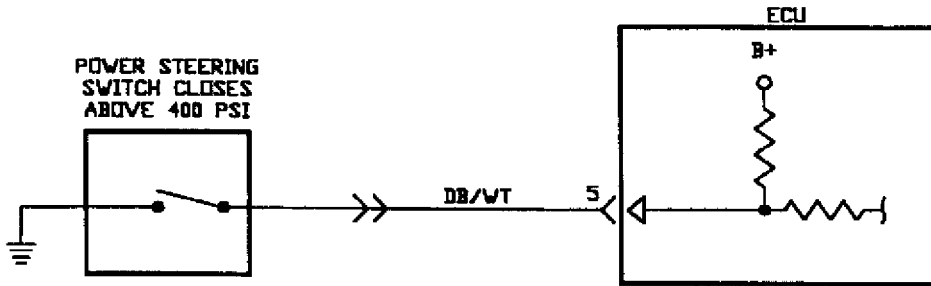

Fig. 71: DR-16 Test Schematic - Power Steering Switch
No Fault Code Sensor Test

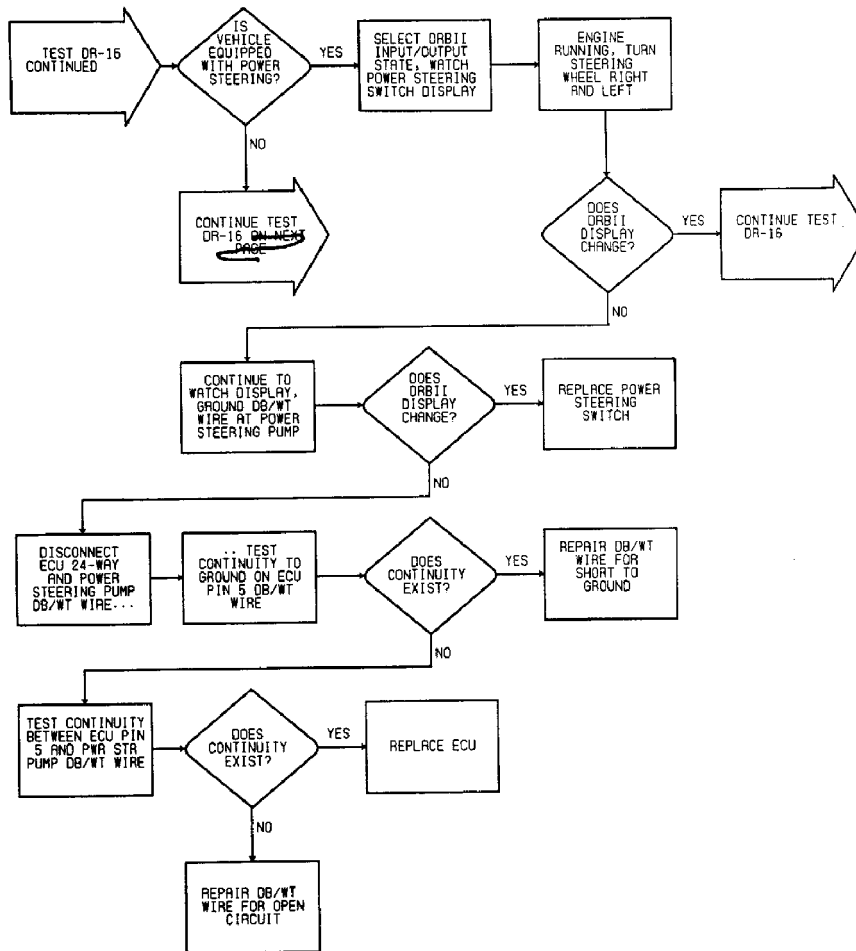

Fig. 72: DR-16 Test Flow Chart (4 Of 5)
No Fault Code Sensor Test

G - TESTS W/CODES

Article Text (p. 70)

1992 Dodge Colt

For a a a a

Copyright © 1998 Mitchell Repair Information Company, LLC

Saturday, April 27, 2002 05:50PM

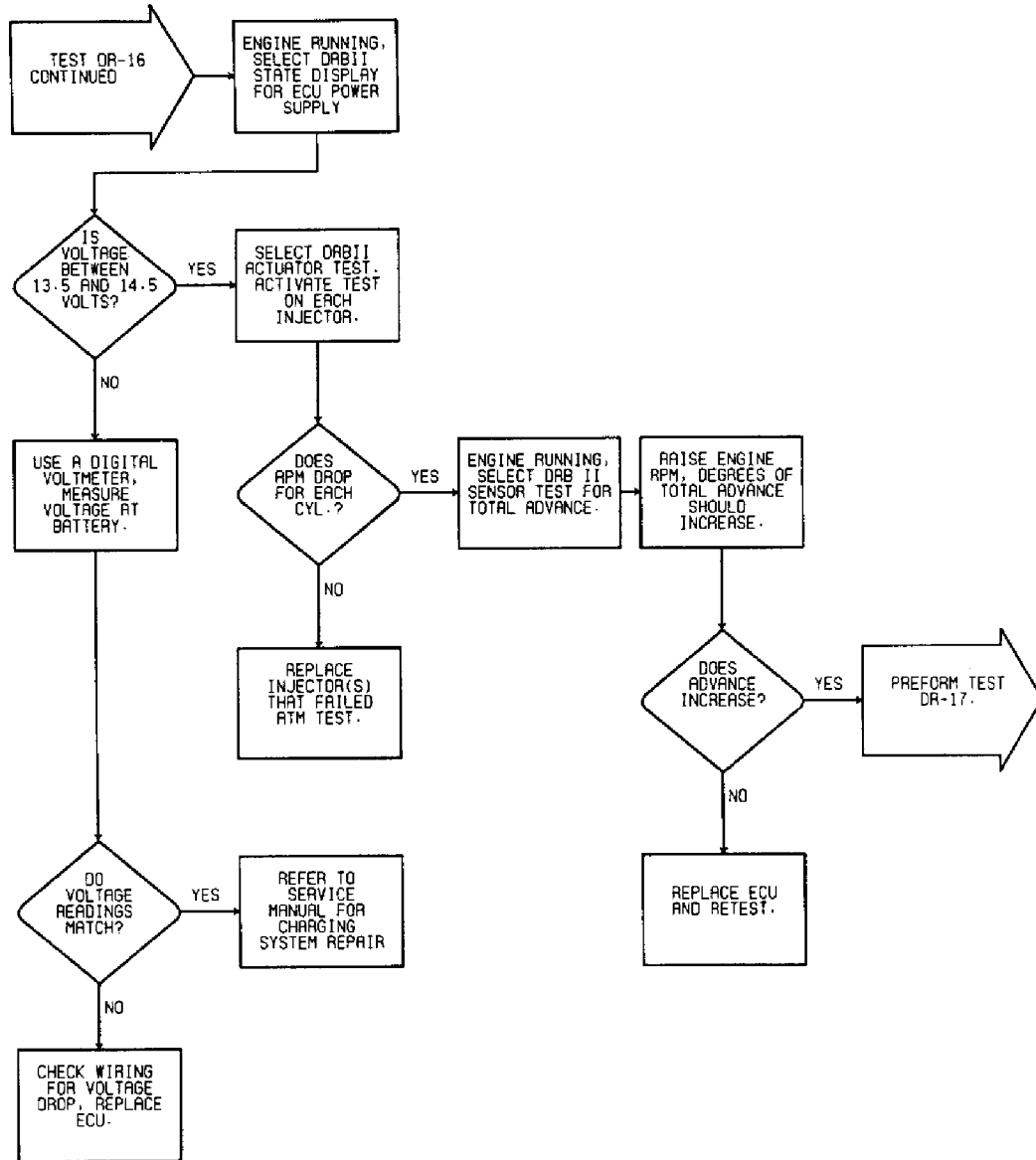

Fig. 73: DR-16 Test Flow Chart (5 Of 5)
No Fault Code Sensor Test

DR-17: TESTING PURGE SOLENOID CIRCUIT

G - TESTS W/CODES

Article Text (p. 71)

1992 Dodge Colt

For a a a a

Copyright © 1998 Mitchell Repair Information Company, LLC

Saturday, April 27, 2002 05:50PM

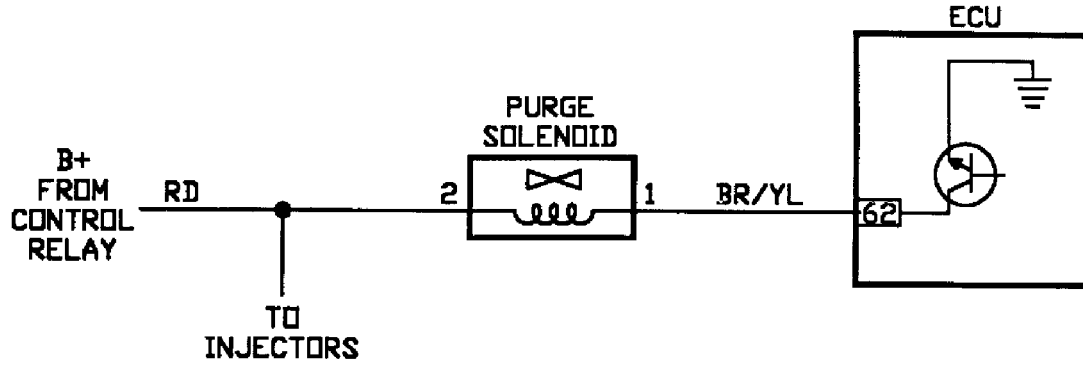

Fig. 74: DR-17 Test Schematic
Testing Purge Solenoid Circuit

G - TESTS W/CODES

Article Text (p. 72)

1992 Dodge Colt

For a a a a

Copyright © 1998 Mitchell Repair Information Company, LLC

Saturday, April 27, 2002 05:50PM

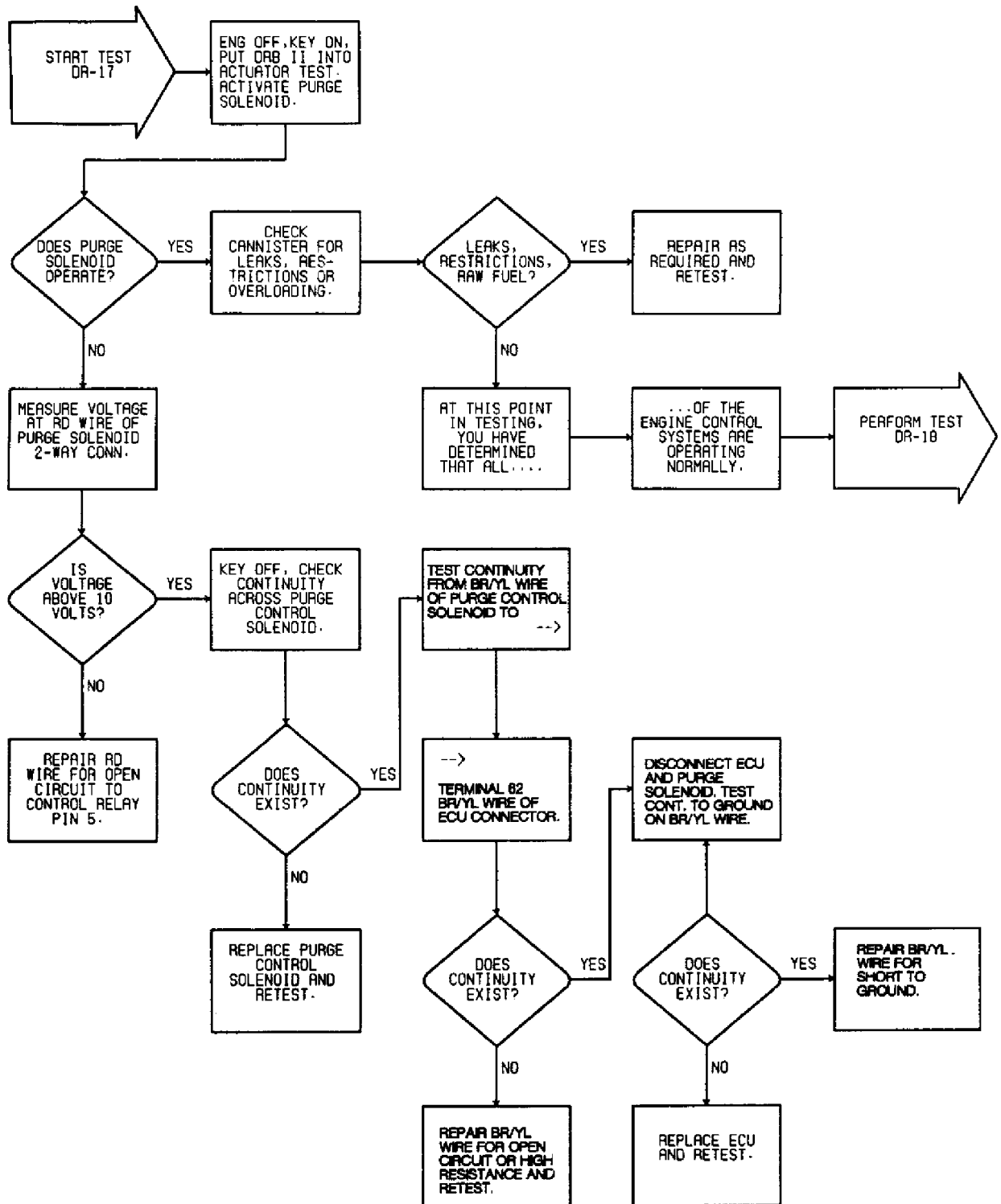

Fig. 75: DR-17 Test Flow Chart Testing Purge Solenoid Circuit

DR-18: NO FAULT CODE MECHANICAL TEST

G - TESTS W/CODES

Article Text (p. 73)

1992 Dodge Colt

For a a a a

Copyright © 1998 Mitchell Repair Information Company, LLC

Saturday, April 27, 2002 05:50PM

At this point in the driveability test procedure, you have determined that all of the engine control systems are operating as they were designed to. Therefore, they are not the cause of the driveability problem.

The following additional items can not be overlooked as possible cause of a driveability problem.

1. THROTTLE VALVE AREA - Dirt or ice buildup causing rough idle and stalling.
2. ENGINE IGNITION TIMING - Must be set with timing terminal grounded.
3. ENGINE VACUUM - Must be normal for your altitude.
4. ENGINE VALVE TIMING - To specifications.
5. ENGINE COMPRESSION - To specifications.
6. ENGINE P.C.V. SYSTEM - Must flow freely.
7. ENGINE EXHAUST SYSTEM - Must be free of any restrictions.
8. POWER BRAKE BOOSTER - No internal vacuum leaks.
9. TORQUE CONVERTER CONDITION - May cause very low power at breakaway or high speed (Only 1 condition at a time).
10. FUEL CONTAMINATION - High alcohol or water content.
11. FUEL INJECTORS - Rough idle may be caused by injector wiring not connected to correct injector.
12. ENGINE SECONDARY IGNITION CHECK - Abnormal scope patterns.
13. TECHNICAL SERVICE BULLETINS - Any that apply to vehicle.
14. All air intake piping and vacuum hoses must be in place and secure. The proper air filter element must be used.
15. FUEL PRESSURE - Must be correct.
Specification: With no vacuum at the regulator:
48 PSI on V6 & non-turbo 4 Cyl. engines
36 PSI on turbo engines

SUMMARY

If no hard fault codes (or only pass codes) are present, driveability symptoms exist or intermittent codes exist, proceed to H - TESTS W/O CODES article in the ENGINE PERFORMANCE Section for diagnosis by symptom (i.e., ROUGH IDLE, NO START, etc.) or intermittent diagnostic procedures.

END OF ARTICLE