

INSTRUMENT PANEL

Article Text

1992 Mitsubishi Mirage

For a a a a

Copyright © 1998 Mitchell Repair Information Company, LLC

Monday, April 01, 2002 09:58AM

ARTICLE BEGINNING

1992 ACCESSORIES & SAFETY EQUIPMENT

Chrysler Motors/Eagle/Mitsubishi Switches & Instrument Panels

Dodge: Colt, Colt 200, Ram-50, Stealth

Eagle: Summit, Summit Wagon

Mitsubishi: Diamante, Eclipse, Expo/Expo LRV, Galant,
Mirage, Montero, Pickup, 3000GT

Plymouth: Colt, Colt 200, Colt Vista

DESCRIPTION & OPERATION

Instrument cluster includes speedometer, fuel gauge and temperature gauge. Fuel gauge has a built-in voltage limiter to keep voltage supply to gauges at 7 volts. Some models may also have a shunt-type ammeter, oil pressure gauge, tachometer, voltmeter and/or turbo boost pressure gauge. Oil pressure gauge uses full battery voltage. The tachometer operates by pulse feed.

TROUBLE SHOOTING

FUEL/TEMPERATURE GAUGE NOT WORKING

Check for blown fuse, faulty voltage limiter and faulty relay. Ensure sending unit connections are clean and tight. Test sending unit for correct operation. Tighten connections in instrument cluster.

SPEEDOMETER NOT WORKING

Ensure speedometer cable is properly connected and correctly routed. If speedometer pointer and/or odometer still do not work, replace speedometer as an assembly.

TACHOMETER NOT WORKING

Tachometer is serviced as an assembly. If wiring harness is okay, replace tachometer assembly.

WARNING LIGHTS NOT WORKING

Test for defective sending unit, burned-out bulb and broken printed circuit. Ensure all connections are clean and tight.

TESTING

BOOST PRESSURE GAUGE

NOTE: Boost pressure gauge testing procedures for Galant are not available from manufacturer.

INSTRUMENT PANEL

Article Text (p. 2)

1992 Mitsubishi Mirage

For a a a a

Copyright © 1998 Mitchell Repair Information Company, LLC

Monday, April 01, 2002 09:58AM

Resistance Test (Eclipse, Stealth & 3000GT Turbo)

1) Remove instrument cluster from instrument panel. See INSTRUMENT CLUSTER under REMOVAL & INSTALLATION. On Stealth and 3000GT, remove air distribution duct and combination gauges.

2) On all models, measure resistance between boost pressure gauge terminals on back of instrument cluster or combination gauges using ohmmeter. See Fig. 1 or 2. Resistance should be 72 ohms. If resistance is not as specified, replace gauge.

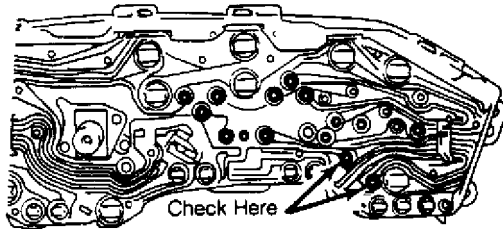

91B01892

ECLIPSE TURBO

Fig. 1: Boost Pressure Gauge Test Terminal ID (Eclipse Turbo)
Courtesy of Chrysler Motors.

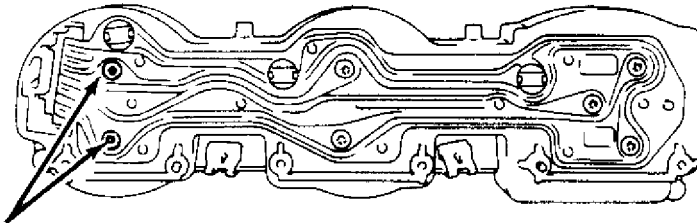

Check Here

92F00187

Fig. 2: Boost Pressure Gauge Test Terminal ID (Stealth & 3000GT Turbo)
Courtesy of Chrysler Motors.

FUEL TANK SENDING UNIT

Resistance Test

Remove fuel tank sending unit from fuel tank. Measure resistance between appropriate terminals with fuel float in FULL and EMPTY positions. See Figs. 3-10. Compare resistance reading to FUEL TANK SENDING UNIT RESISTANCE SPECIFICATIONS table. If resistance is not to specification, replace fuel tank sending unit.

FUEL TANK SENDING UNIT RESISTANCE SPECIFICATIONS TABLE

Application	Empty	Full
Diamante	109.0-111.0	2.0-4.0

INSTRUMENT PANEL

Article Text (p. 3)

1992 Mitsubishi Mirage

For a a a a

Copyright © 1998 Mitchell Repair Information Company, LLC

Monday, April 01, 2002 09:58AM

Expo (Except LRV)			
FWD	102.3-117.7	0.9-5.1
4WD (1)			
Main	69.4-79.5	0.7-2.7
Sub	32.4-37.7	0.7-2.7
Expo LRV, Colt Vista & Summit Wagon			
FWD	102.3-117.7	0.9-5.1
4WD (1)			
Main	72.2-83.0	0.7-2.9
Sub	30.1-34.7	0.4-2.0
All Others	103.0-117.0	1.0-5.0

(1) - Equipped with a main fuel sender and a sub fuel sender.

FUEL GAUGE

CAUTION: Gauge coils can be damaged if wire is grounded too long. Perform test as quickly as possible.

Simple Test

1) Disconnect fuel gauge sending unit connector wire in luggage compartment, in cargo space or at tank unit. Connect a 12-volt, 3.4-watt bulb to harness side of connector, between appropriate terminals. See Figs. 3-10.

2) Turn ignition switch to ON position. Ensure test bulb flashes, or stays on, and fuel gauge needle moves. If bulb or gauge needle does not function as described, check and repair fuel gauge circuit.

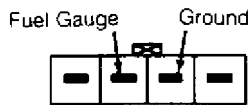

ECLIPSE 4WD & GALANT 4WD

93J01075

Fig. 3: Fuel Gauge Test Connections ID (Eclipse & Galant 4WD)
Courtesy of Chrysler Motors.

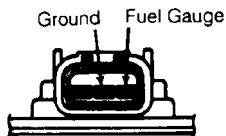

ECLIPSE FWD &
GALANT FWD

93B01076

Fig. 4: Fuel Gauge Test Connections ID (Eclipse & Galant FWD)
Courtesy of Chrysler Motors.

INSTRUMENT PANEL

Article Text (p. 4)

1992 Mitsubishi Mirage

For a a a a

Copyright © 1998 Mitchell Repair Information Company, LLC

Monday, April 01, 2002 09:58AM

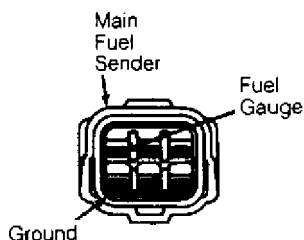

EXPO 4WD, SUMMIT WAGON 4WD
& VISTA WAGON 4WD

93D01077

Fig. 5: Fuel Gauge Test Connections ID (Expo/Expo LRV, Summit Wagon & Colt Vista 4WD)
Courtesy of Chrysler Motors.

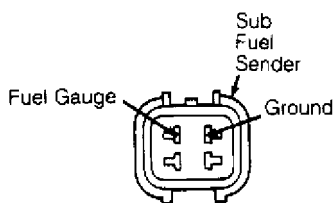

EXPO 4WD, SUMMIT WAGON 4WD
& VISTA WAGON 4WD

93F01078

Fig. 6: Fuel Gauge Test Connections ID (Expo/Expo LRV, Summit Wagon & Colt Vista 4WD)
Courtesy of Chrysler Motors.

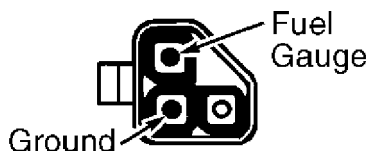

93H01079

Fig. 7: Fuel Gauge Test Connections ID (Colt, Colt 200, Expo/Expo LRV FWD, Mirage, Montero, Summit, Summit Wagon & Colt Vista FWD)
Courtesy of Chrysler Motors.

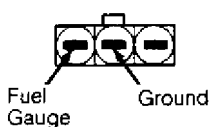

DIAMANTE

93J01080

Fig. 8: Fuel Gauge Test Connections ID (Diamante)
Courtesy of Chrysler Motors.

INSTRUMENT PANEL

Article Text (p. 5)

1992 Mitsubishi Mirage

For a a a a

Copyright © 1998 Mitchell Repair Information Company, LLC

Monday, April 01, 2002 09:58AM

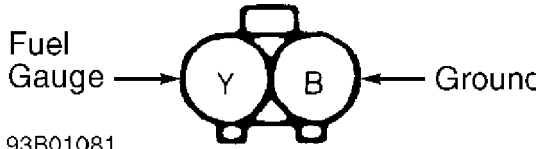

93R01081

Fig. 9: Fuel Gauge Test Connections ID (Pickup & Ram-50)
Courtesy of Chrysler Motors.

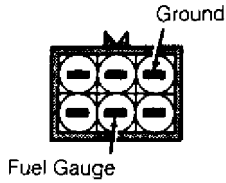

STEALTH & 3000GT

93F01083

Fig. 10: Fuel Gauge Test Connections ID (Stealth & 3000GT)
Courtesy of Chrysler Motors.

NOTE: Fuel gauge resistance test must be completed with instrument panel cluster removed. Use ohmmeter for all measurements. If resistance is extremely low, a short may exist in coil. If resistance is extremely high, a broken wire or similar problem may exist in gauge.

Resistance Test

1) Remove instrument cluster. See INSTRUMENT CLUSTER under REMOVAL & INSTALLATION. On Stealth and 3000GT, remove air distribution duct and combination gauges.

2) On all models, measure resistance between appropriate terminals of instrument cluster or combination gauges. See Figs. 11-20. See FUEL GAUGE RESISTANCE SPECIFICATIONS table. If resistance readings are not to specification, replace fuel gauge.

FUEL GAUGE RESISTANCE SPECIFICATIONS TABLE

Application	Terminals	Ohms
Colt, Colt 200, Mirage & Summit	"A" & "B"	77.0-93.0
"	"A" & "C"	59.0-71.0
"	"B" & "C"	76.0-92.0
Diamante	"A" & "B"	247.0-301.0
"	"A" & "C"	78.0-94.0
"	"B" & "C"	170.0-206.0
Eclipse	"A" & "B"	230.0
"	"A" & "C"	102.0
"	"B" & "C"	102.0
Colt Vista, Expo/Expo LRV & Summit Wagon		
With Tachometer	"A" & "B"	82.8-101.2
"	"A" & "C"	58.5-71.5

INSTRUMENT PANEL

Article Text (p. 6)

1992 Mitsubishi Mirage

For a a a a

Copyright © 1998 Mitchell Repair Information Company, LLC
Monday, April 01, 2002 09:58AM

"	"B" & "C"	85.5-104.5
Without Tachometer	"A" & "B"	218.0-267.3
"	"A" & "C"	24.7-91.3
"	"B" & "C"	144.0-176.0
Galant	"A" & "B"	203.0
"	"A" & "C"	102.0
"	"B" & "C"	102.0
Montero	No. 2 & 3	209.7-256.3
"	No. 1 & 2	77.4-94.6
"	No. 1 & 3	132.3-161.7
Pickup & Ram-50	IGN & "E"	62.0-78.0
"	7V & FU	49.0-61.0
Stealth & 3000GT	"A" & "B"	254.0
"	"A" & "C"	101.0
"	"B" & "C"	153.0

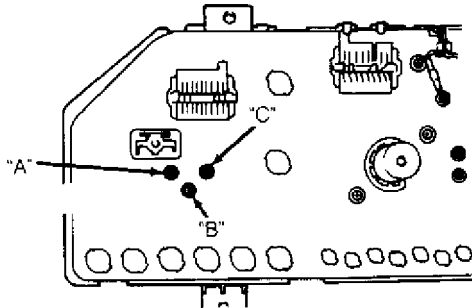

EXPO, SUMMIT WAGON & VISTA
WAGON WITHOUT TACHOMETER

93A01085

Fig. 11: Fuel Gauge Resistance Check Term. ID (Colt Vista, Expo/Expo LRV & Summit Wagon) (W/Tachometer)
Courtesy of Mitsubishi Motor Sales of America

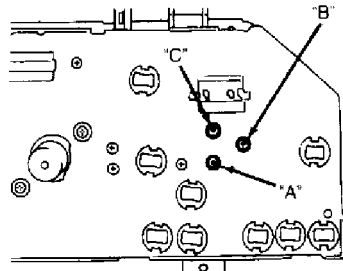

EXPO, SUMMIT WAGON & VISTA
WAGON WITH TACHOMETER

93C01086

Fig. 12: Fuel Gauge Resistance Check Term. ID (Colt Vista, Expo/Expo LRV & Summit Wagon) (W/O Tachometer)
Courtesy of Mitsubishi Motor Sales of America

INSTRUMENT PANEL

Article Text (p. 7)

1992 Mitsubishi Mirage

For a a a a

Copyright © 1998 Mitchell Repair Information Company, LLC

Monday, April 01, 2002 09:58AM

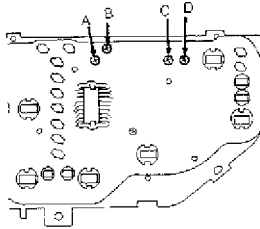

COLT, COLT 200, MIRAGE & SUMMIT
WITH TACHOMETER

Fig. 13: Fuel Gauge Resistance Check Term. ID (Colt, Colt 200, Mirage & Summit W/ Tachometer)

Courtesy of Mitsubishi Motor Sales of America.

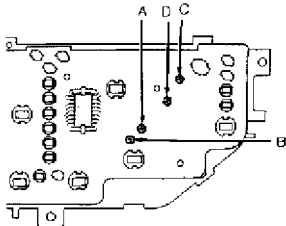

COLT, COLT 200, MIRAGE & SUMMIT
WITHOUT TACHOMETER

Fig. 14: Fuel Gauge Resistance Check Term. ID (Colt, Colt 200, Mirage & Summit W/O Tachometer)

Courtesy of Mitsubishi Motor Sales of America.

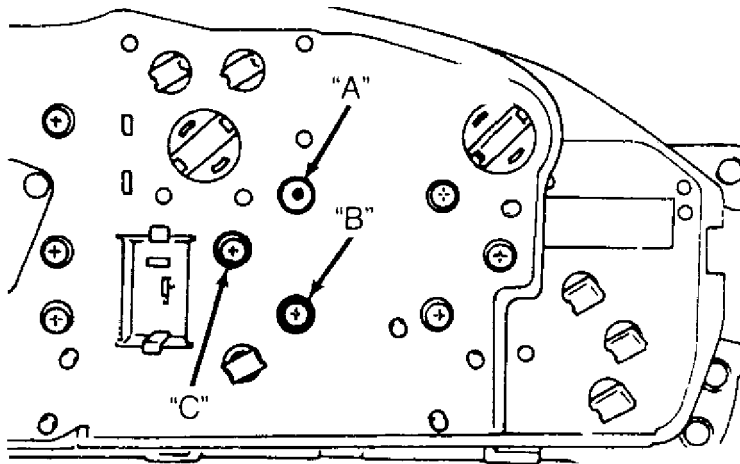

93H01084

Fig. 15: Fuel Gauge Resistance Check Term. ID (Diamante)

Courtesy of Mitsubishi Motor Sales of America.

INSTRUMENT PANEL

Article Text (p. 8)

1992 Mitsubishi Mirage

For a a a a

Copyright © 1998 Mitchell Repair Information Company, LLC

Monday, April 01, 2002 09:58AM

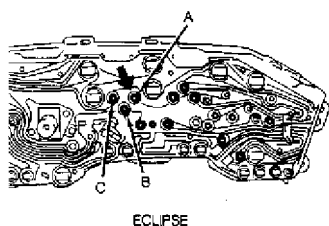

Fig. 16: Fuel Gauge Resistance Check Term. ID (Eclipse)
Courtesy of Mitsubishi Motor Sales of America.

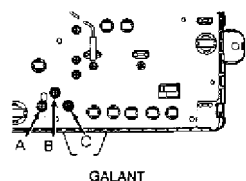

Fig. 17: Fuel Gauge Resistance Check Term. ID (Galant)
Courtesy of Mitsubishi Motor Sales of America.

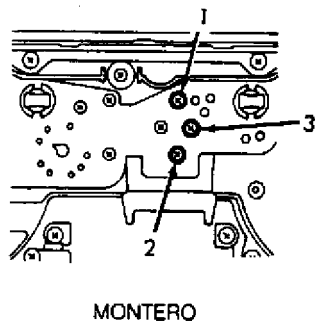

Fig. 18: Fuel Gauge Resistance Check Term. ID (Montero)
Courtesy of Mitsubishi Motor Sales of America.

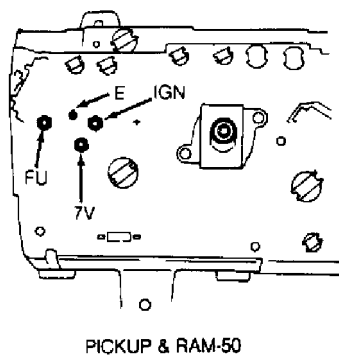

Fig. 19: Fuel Gauge Resistance Check Term. ID (Pickup & Tam-50)
Courtesy of Mitsubishi Motor Sales of America.

INSTRUMENT PANEL

Article Text (p. 9)

1992 Mitsubishi Mirage

For a a a a

Copyright © 1998 Mitchell Repair Information Company, LLC

Monday, April 01, 2002 09:58AM

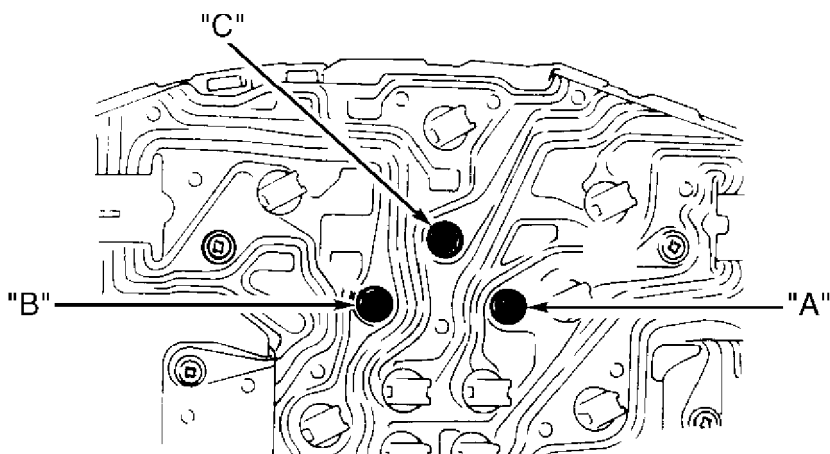

92H00189

Fig. 20: Fuel Gauge Resistance Check Term. ID (Stealth & 3000GT)
Courtesy of Mitsubishi Motor Sales of America.

OIL PRESSURE GAUGE

Circuit Test (Eclipse, Montero, Pickup, Ram-50, Stealth & 3000GT)

1) Disconnect oil pressure gauge wiring connector from sending unit inside engine compartment. Connect a 12-volt test light between harness connector terminal and ground. Turn ignition on, but DO NOT start engine.

2) If test light comes on and gauge needle moves, go to GAUGE RESISTANCE TEST. If test light does not come on and gauge needle does not move, repair wiring to sending unit.

Gauge Resistance Test (Eclipse, Montero, Pickup, Ram-50, Stealth & 3000GT)

1) Remove instrument cluster from instrument panel. See INSTRUMENT CLUSTER under REMOVAL & INSTALLATION. On Stealth and 3000GT, remove air distribution duct and combination gauges.

2) On all models, check continuity between oil pressure gauge terminals. See Figs. 21-24. See OIL PRESSURE GAUGE RESISTANCE SPECIFICATIONS table. If resistance is not within specification, replace oil pressure gauge.

OIL PRESSURE GAUGE RESISTANCE SPECIFICATIONS TABLE

Application	Ohms
Eclipse, Stealth & 3000GT	42
Montero	50
Pickup & Ram-50	37-47

INSTRUMENT PANEL

Article Text (p. 10)

1992 Mitsubishi Mirage

For a a a a

Copyright © 1998 Mitchell Repair Information Company, LLC

Monday, April 01, 2002 09:58AM

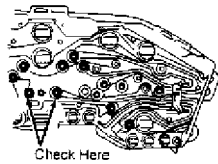

ECLIPSE

Fig. 21: Oil Pressure Gauge Resistance Test Term. ID (Eclipse)
Courtesy of Chrysler Motors.

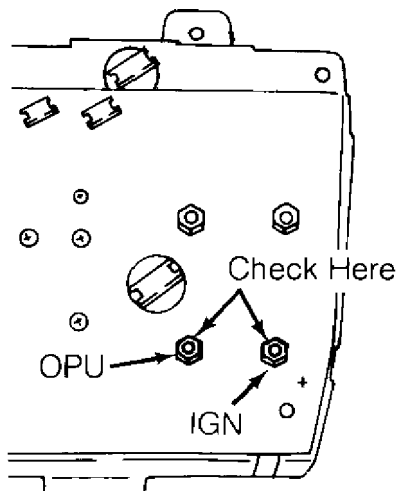

91H01890

Fig. 22: Oil Pressure Gauge Resistance Test Term. ID (Pickup, Ram-50)
Courtesy of Chrysler Motors.

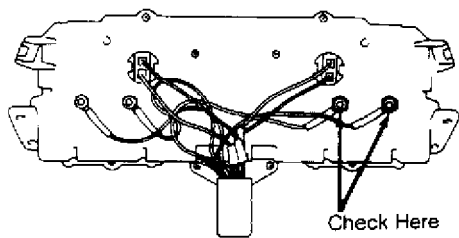

93G01088

Fig. 23: Oil Pressure Gauge Resistance Test Term. ID (Montero)
Courtesy of Chrysler Motors.

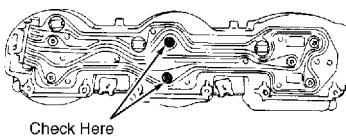

92A01190

Fig. 24: Oil Pressure Gauge Resistance Test Term. ID (Stealth & 3000GT)
Courtesy of Chrysler Motors.

INSTRUMENT PANEL

Article Text (p. 11)

1992 Mitsubishi Mirage

For a a a a

Copyright © 1998 Mitchell Repair Information Company, LLC
Monday, April 01, 2002 09:58AM

REED SWITCH

Continuity Check (Except Pickup & Ram-50)

1) Remove instrument cluster. See INSTRUMENT CLUSTER under REMOVAL & INSTALLATION. Check continuity between reed switch terminals No. 1 and 2. See Figs. 25-31.

2) Ensure continuity pulses on and off 4 times per revolution of speedometer shaft connection. If continuity is not as specified, replace reed switch.

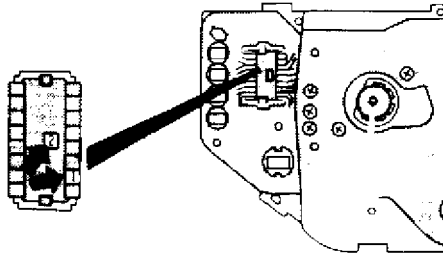

COLT, COLT 200, MIRAGE & SUMMIT

92B00191

Fig. 25: Reed Switch Test Terminal ID (Colt, Colt 200, Mirage & Summit)

Courtesy of Mitsubishi Motor Sales of America.

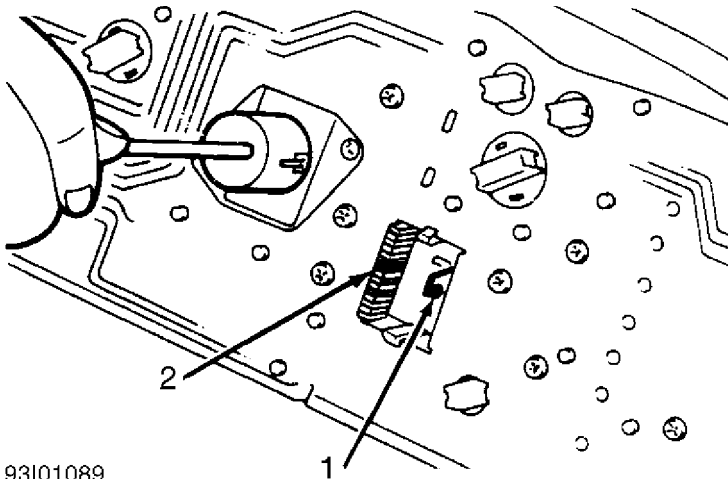

93101089

Fig. 26: Reed Switch Test Terminal ID (Diamante)

Courtesy of Mitsubishi Motor Sales of America.

INSTRUMENT PANEL

Article Text (p. 12)

1992 Mitsubishi Mirage

For a a a a

Copyright © 1998 Mitchell Repair Information Company, LLC

Monday, April 01, 2002 09:58AM

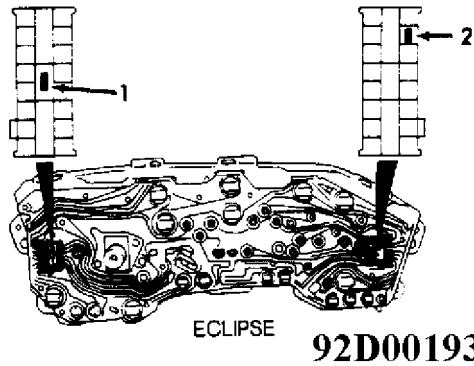

Fig. 27: Reed Switch Test Terminal ID (Eclipse)
Courtesy of Mitsubishi Motor Sales of America.

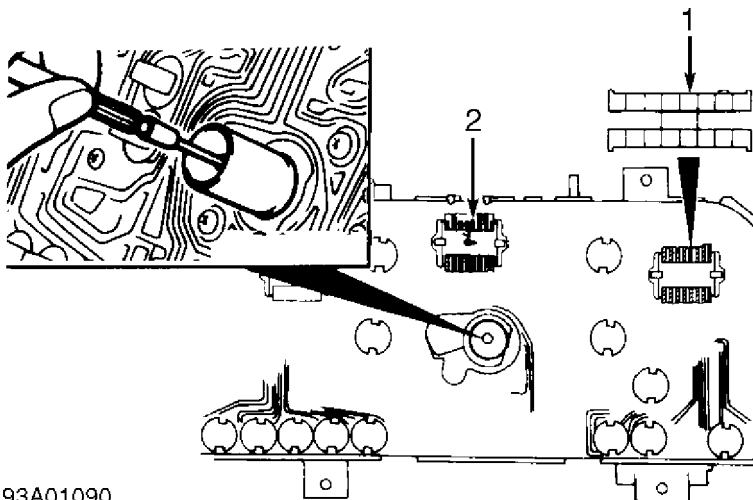

Fig. 28: Reed Switch Test Terminal ID (Colt Vista, Expo/Expo LRV
& Summit Wagon)
Courtesy of Mitsubishi Motor Sales of America.

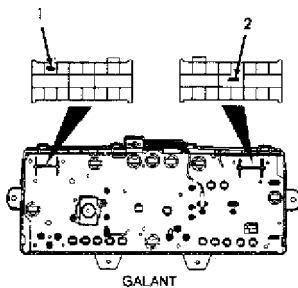

Fig. 29: Reed Switch Test Terminal ID (Galant)
Courtesy of Mitsubishi Motor Sales of America.

INSTRUMENT PANEL

Article Text (p. 13)

1992 Mitsubishi Mirage

For a a a a

Copyright © 1998 Mitchell Repair Information Company, LLC

Monday, April 01, 2002 09:58AM

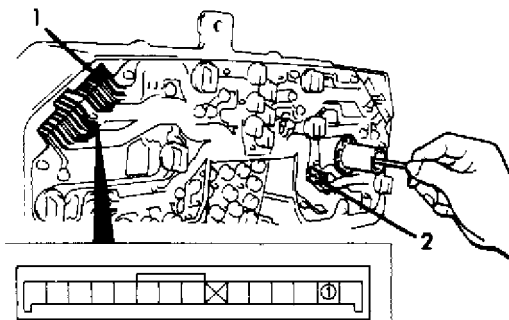

MONTERO

93A01090

Fig. 30: Reed Switch Test Terminal ID (Montero)
Courtesy of Mitsubishi Motor Sales of America.

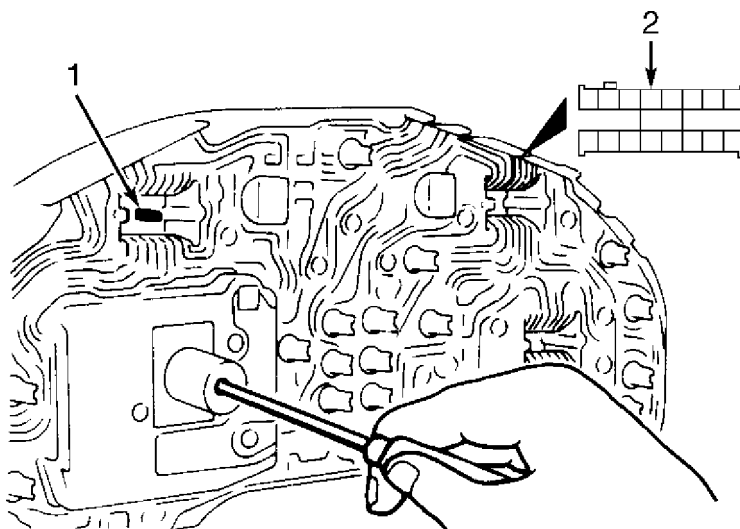

92G00196

Fig. 31: Reed Switch Test Terminal ID (Stealth & 3000GT)
Courtesy of Mitsubishi Motor Sales of America.

SPEED SENSOR

Voltage Test (Stealth & 3000GT With Electronic Speedometer)

Remove speed sensor from transmission. Connect speed sensor, resistor (3000-10,000 ohms) and battery. See Fig. 32. Using a voltmeter, ensure voltage pulses on and off 4 times per revolution of speedometer shaft. Replace sensor if voltage is not as specified.

INSTRUMENT PANEL

Article Text (p. 14)

1992 Mitsubishi Mirage

For a a a a

Copyright © 1998 Mitchell Repair Information Company, LLC

Monday, April 01, 2002 09:58AM

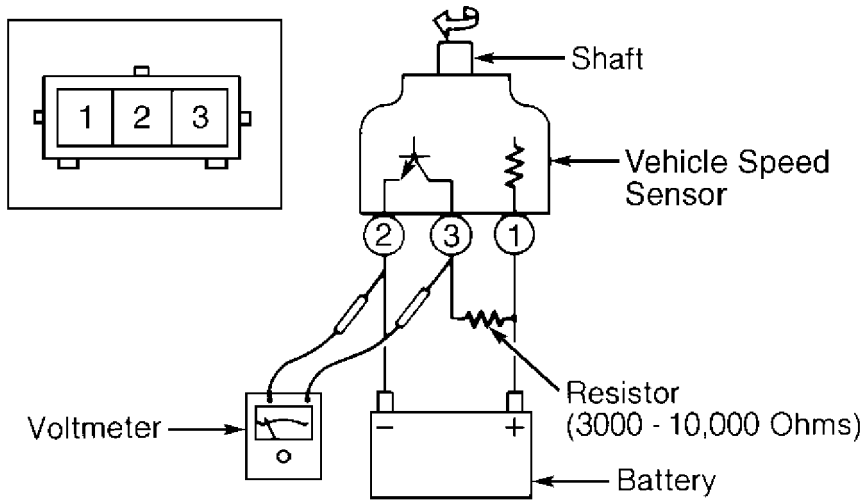

92H00197

Fig. 32: Testing Speed Sensor (Stealth & 3000GT - W/ Electronic Speedometer)

Courtesy of Mitsubishi Motor Sales of America.

SPEEDOMETER

Calibration Test

Adjust tire pressure to standard value. Using a calibrated, reliable speedometer tester, compare reading of vehicle speedometer to speedometer tester. See SPEEDOMETER ALLOWABLE VARIATION table. Replace speedometer if necessary.

SPEEDOMETER ALLOWABLE VARIATION TABLE

MPH (km/h)	Allowable Variation MPH (km/h)
20 (32)	19-22 (31-35)
40 (64)	38-44 (61-71)
60 (97)	57-66 (92-106)
80 (129)	76-88 (122-142)
100 (161)	94-110 (151-177)

TACHOMETER

NOTE: DO NOT reverse polarity when installing tachometer; diode and transistor may be damaged.

Calibration Test

Connect a calibrated, reliable tach-dwell meter to vehicle ignition system. Operate engine at various speeds (RPM). See TACHOMETER ALLOWABLE VARIATION table. If comparison between tach-dwell meter and vehicle tachometer readings are not within permissible variation, replace vehicle tachometer.

TACHOMETER ALLOWABLE VARIATION TABLE

INSTRUMENT PANEL

Article Text (p. 15)

1992 Mitsubishi Mirage

For a a a a

Copyright © 1998 Mitchell Repair Information Company, LLC

Monday, April 01, 2002 09:58AM

Engine Speed (RPM)	Allowable Variation (RPM)
Colt, Colt 200 & Summit	
1000	900-1100
3000	2800-3100
5000	4625-5100
Colt Vista, Diamante, Expo/Expo LRV, Montero, Stealth, Summit Wagon & 3000GT	
1000	900-1100
3000	2850-3150
5000	4750-5250
6000	5700-6300
Eclipse	
8000-RPM Tachometer	
700	600-800
3000	2850-3150
5000	4750-5250
9000-RPM Tachometer	
700	600-800
3000	2900-3225
5000	4900-5325
Galant	
8000-RPM Tachometer	
700	600-800
3000	2850-3150
6000	5700-6300
9000-RPM Tachometer	
700	600-800
3000	2900-3225
7000	6900-7400
Mirage	
8000-RPM Tachometer	
1000	900-1100
3000	2800-3100
5000	4625-5100
9000-RPM Tachometer	
1000	900-1100
3000	2900-3225
5000	4875-5325
Pickup & Ram-50	
1000	900-1100
3000	2850-3150
6000	5700-6300

TEMPERATURE GAUGE

CAUTION: DO NOT connect sender wire directly to ground during test.

Circuit Test

- 1) Disconnect temperature sender wire from sending unit.

INSTRUMENT PANEL

Article Text (p. 16)

1992 Mitsubishi Mirage

For a a a a

Copyright © 1998 Mitchell Repair Information Company, LLC

Monday, April 01, 2002 09:58AM

Connect a 12-volt, 3.4-watt test light between connector terminal and ground. Turn ignition switch to ON position.

2) If test light flashes and temperature gauge needle moves, go to SENSOR RESISTANCE TEST. If test light does not flash or gauge needle does not move, repair wiring to sending unit.

Sensor Resistance Test

1) Remove thermosensor (sending unit) from engine. See THERMOSENSOR LOCATION table. Place sending unit in 158°F (70°C) water. Check sensor resistance using ohmmeter.

2) Thermosensor resistance should be 90-117 ohms. If thermosensor resistance is okay, go to GAUGE RESISTANCE TEST. Replace thermosensor if resistance is not as specified.

Gauge Resistance Test

1) Remove instrument cluster from instrument panel. See INSTRUMENT CLUSTER under REMOVAL & INSTALLATION. On Stealth and 3000GT, remove air distribution duct and combination gauges.

2) On all models, measure resistance between temperature gauge terminals at rear of cluster or combination gauges. See TEMPERATURE GAUGE RESISTANCE SPECIFICATIONS table. See Figs. 33-42.

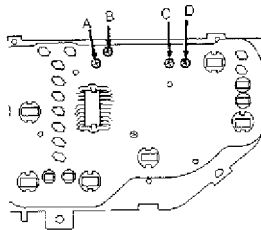

COLT, COLT 200, MIRAGE & SUMMIT
WITH TACHOMETER

Fig. 33: Temperature Gauge Resistance Test Terminal ID (Colt, Colt 200, Mirage & Summit W/ Tach)

Courtesy of Mitsubishi Motor Sales of America.

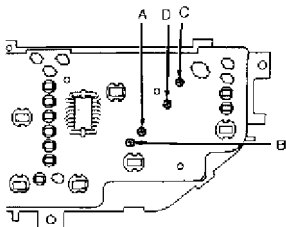

COLT, COLT 200, MIRAGE & SUMMIT
WITHOUT TACHOMETER

Fig. 34: Temperature Gauge Resistance Test Terminal ID (Colt, Colt 200, Mirage & Summit W/O Tach)

Courtesy of Mitsubishi Motor Sales of America.

INSTRUMENT PANEL

Article Text (p. 17)

1992 Mitsubishi Mirage

For a a a a

Copyright © 1998 Mitchell Repair Information Company, LLC

Monday, April 01, 2002 09:58AM

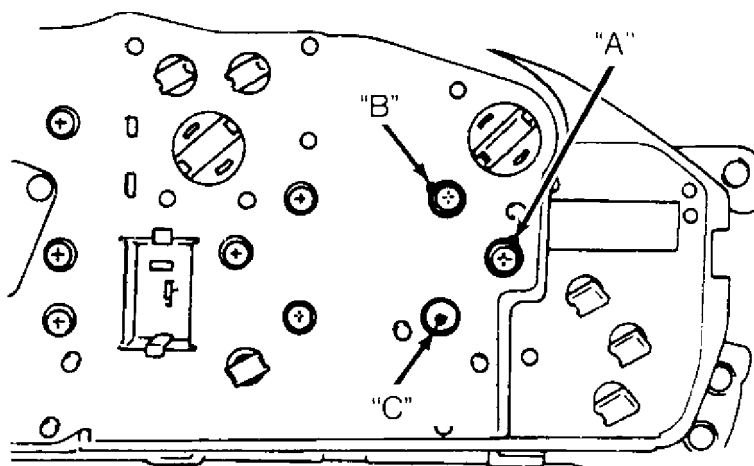

93G01093

Fig. 35: Temperature Gauge Resistance Test Terminal ID (Diamante)
Courtesy of Mitsubishi Motor Sales of America.

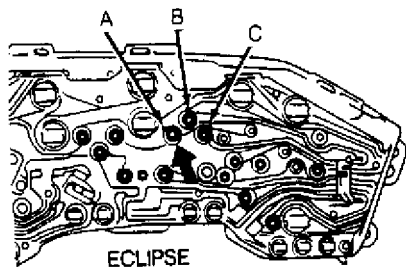

91D01888

Fig. 36: Temperature Gauge Resistance Test Terminal ID (Eclipse)
Courtesy of Mitsubishi Motor Sales of America.

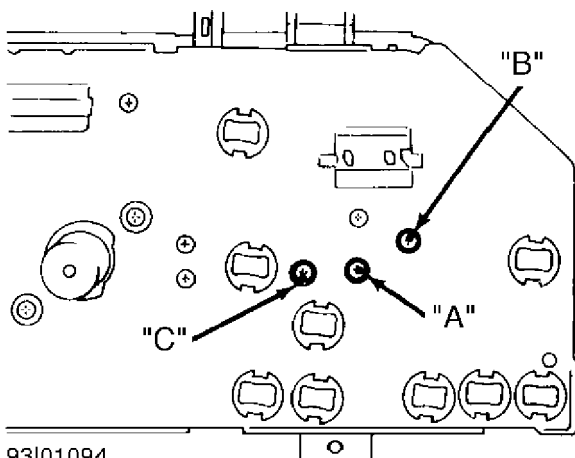

93I01094

Fig. 37: Temperature Gauge Resistance Test Terminal ID (Colt Vista, Expo/Expo LRV & Summit Wagon W/Tachometer)
Courtesy of Mitsubishi Motor Sales of America.

INSTRUMENT PANEL

Article Text (p. 18)

1992 Mitsubishi Mirage

For a a a a

Copyright © 1998 Mitchell Repair Information Company, LLC

Monday, April 01, 2002 09:58AM

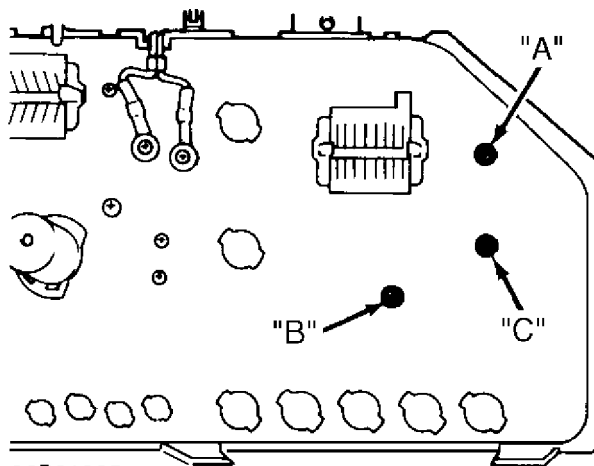

93B01095

Fig. 38: Temperature Gauge Resistance Test Terminal ID (Colt Vista, Expo/Expo LRV & Summit Wagon W/O Tachometer)
Courtesy of Mitsubishi Motor Sales of America.

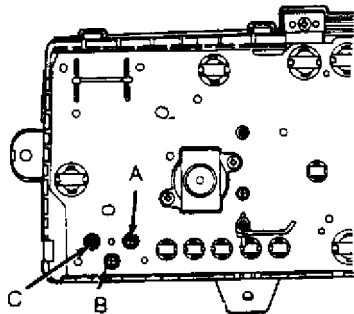

GALANT

Fig. 39: Temperature Gauge Resistance Test Terminal ID (Galant)
Courtesy of Mitsubishi Motor Sales of America.

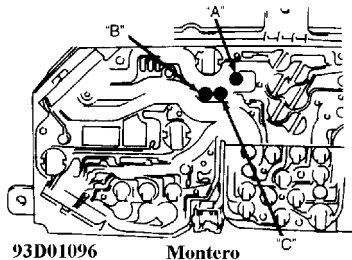

93D01096

Montero

Fig. 40: Temperature Gauge Resistance Test Terminal ID (Montero)
Courtesy of Mitsubishi Motor Sales of America.

INSTRUMENT PANEL

Article Text (p. 19)

1992 Mitsubishi Mirage

For a a a a

Copyright © 1998 Mitchell Repair Information Company, LLC
Monday, April 01, 2002 09:58AM

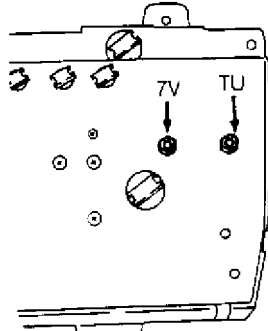

103938

Fig. 41: Temperature Gauge Resistance Test Terminal ID (Pickup & Ram -50)

Courtesy of Mitsubishi Motor Sales of America.

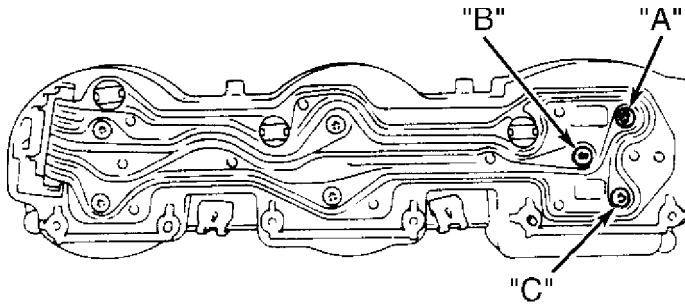

92100198

Fig. 42: Temperature Gauge Resistance Test Terminal ID (Stealth & 3000GT)

Courtesy of Mitsubishi Motor Sales of America.

THERMOSENSOR LOCATION TABLE

Model	Location
Colt Vista, Diamante, Expo/Expo LRV, Stealth DOHC, Summit Wagon & 3000GT	Thermostat Housing
All Others	Intake Manifold

TEMPERATURE GAUGE RESISTANCE SPECIFICATIONS TABLE

Application	Terminals	Ohms
Colt, Colt 200, Mirage & Summit	"B" & "D"	144.0-174.0
"	"C" & "D"	68.0-82.0
"	"B" & "C"	76.0-92.0
Diamante	"A" & "C"	46.0-56.0
"	"B" & "C"	117.0-143.0
"	"A" & "B"	163.0-199.0
Eclipse	"A" & "B"	130.0

INSTRUMENT PANEL

Article Text (p. 20)

1992 Mitsubishi Mirage

For a a a a

Copyright © 1998 Mitchell Repair Information Company, LLC

Monday, April 01, 2002 09:58AM

"	"A" & "C"	53.0
"	"B" & "C"	162.0
Colt Vista, Expo/Expo LRV & Summit Wagon		
Without Tachometer	"A" & "B"	200.7-245.3
"	"A" & "C"	71.3-78.8
"	"B" & "C"	133.2-162.8
With Tachometer	"A" & "B"	82.8-101.2
"	"A" & "C"	71.3-78.8
"	"B" & "C"	150.3-183.7
Galant	"A" & "B"	146.0
"	"A" & "C"	60.0
"	"B" & "C"	206.0
Montero	"A" & "B"	67.5-82.5
"	"A" & "C"	132.3-161.7
"	"B" & "C"	199.8-244.2
Pickup & Ram-50	7V & TU	49.0-61.0
Stealth & 3000GT	"A" & "B"	51.0
"	"A" & "C"	139.0
"	"B" & "C"	190.0

VOLTMETER

Resistance Test (Montero)

Using an ohmmeter, measure resistance between voltmeter terminals. See Fig. 43. Resistance should be 380-460 ohms.

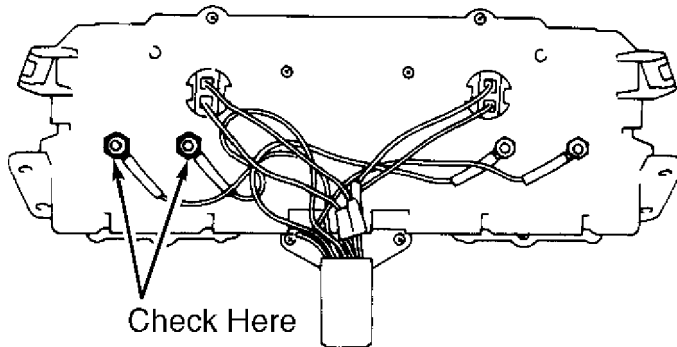

93D01100

Fig. 43: Voltmeter Resistance Test Terminal ID (Montero)
Courtesy of Mitsubishi Motor Sales of America.

Voltage Test (Pickup & Ram-50)

Connect positive voltmeter lead to terminal No. 7 of fuse box. Ground negative terminal. Crank engine and compare readings of vehicle voltmeter to test voltmeter. Difference should not be more than one volt. Replace voltmeter if voltage reading is not as specified.

Voltage Test (Stealth & 3000GT)

Start engine, and let it idle. Connect voltmeter to battery.

INSTRUMENT PANEL

Article Text (p. 21)

1992 Mitsubishi Mirage

For a a a a

Copyright © 1998 Mitchell Repair Information Company, LLC

Monday, April 01, 2002 09:58AM

Compare voltage reading of test voltmeter to voltage reading of vehicle voltmeter. Voltage variation should not exceed 0.5 volt (plus or minus). Replace voltmeter if voltage reading is not as specified.

REMOVAL & INSTALLATION

INSTRUMENT CLUSTER

Removal & Installation (Colt, Colt 200, Mirage & Summit)

1) Disconnect negative battery cable. Remove center panel, knee protector, gauge bezel, combination meter and adapter. Remove bulb socket, bulb, gauge glass and speedometer. See Fig. 44 or 45.

2) Remove gauge cluster (or tachometer and gauge), left indicator lens and turn and high beam indicator lens. Remove A/T position indicator light, lens, printed circuit board and meter case. To install, reverse removal procedure.

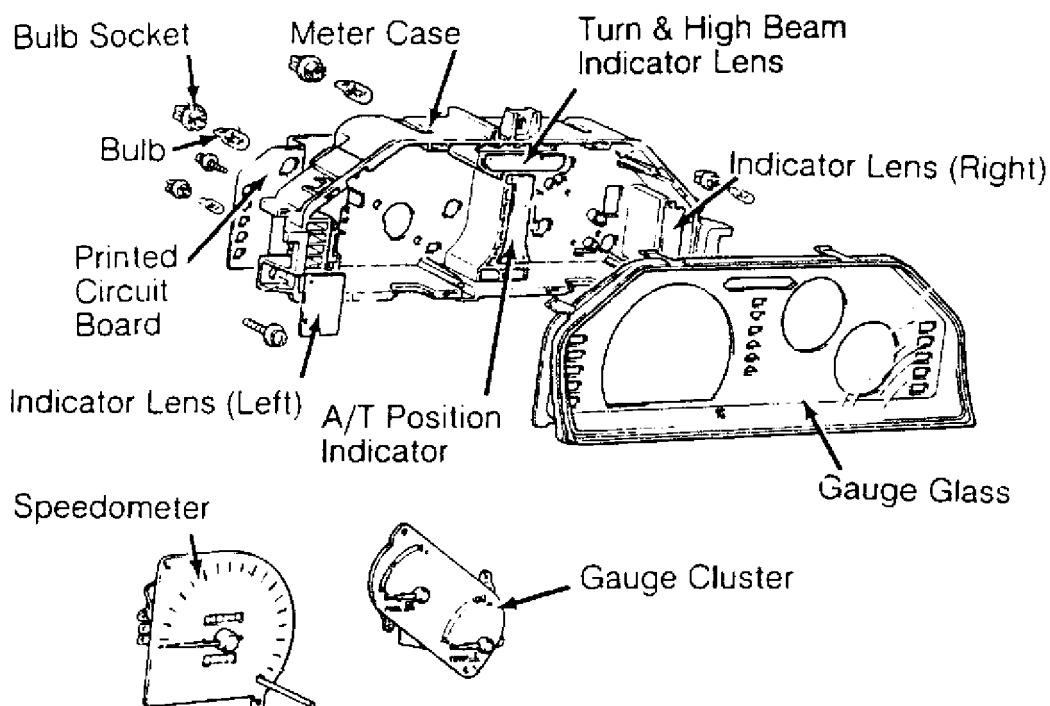

WITHOUT TACHOMETER

93E04000

Fig. 44: Instrument Cluster Component ID (Colt, Colt 200, Mirage & Summit) (W/O Tach)

Courtesy of Chrysler Motors

INSTRUMENT PANEL

Article Text (p. 22)

1992 Mitsubishi Mirage

For a a a a

Copyright © 1998 Mitchell Repair Information Company, LLC

Monday, April 01, 2002 09:58AM

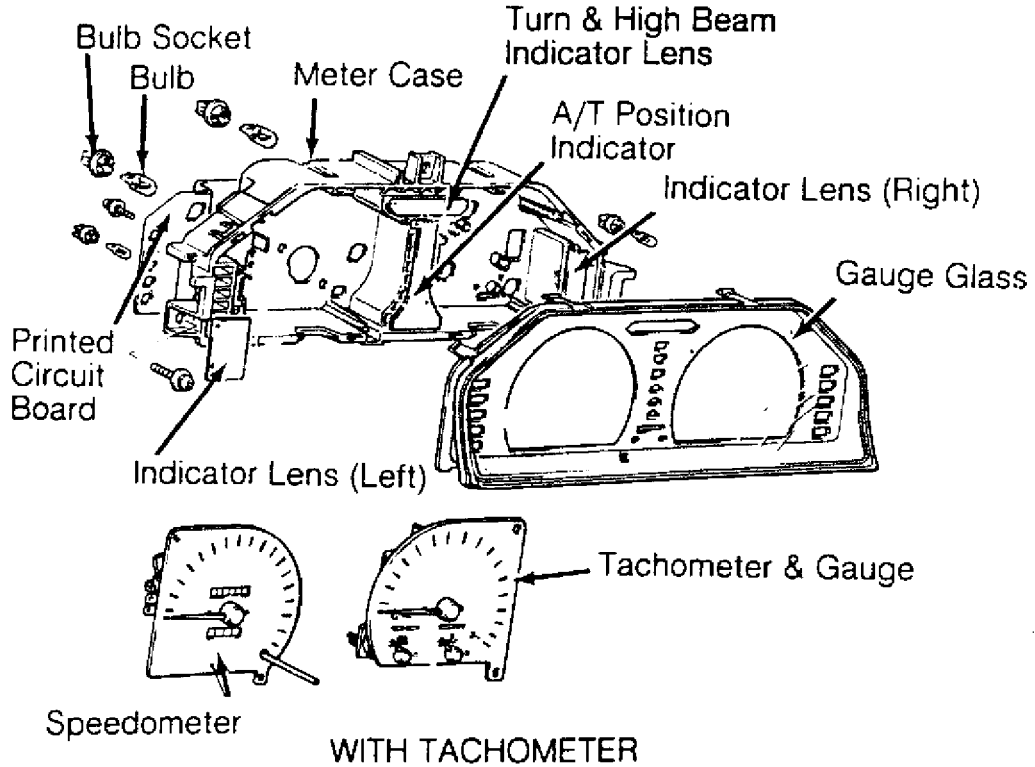

93G04001

Fig. 45: Instrument Cluster Component ID (Colt, Colt 200, Mirage & Summit) (W/ Tach)

Courtesy of Chrysler Motors

Removal & Installation (Diamante)

Disconnect negative battery cable. Remove gauge bezel. Remove screws holding gauge assembly in place. Remove instrument cluster. Remove trip meter reset button. See Fig. 46. Remove gauge glass and plate. Remove gauges as necessary. To install, reverse removal procedure.

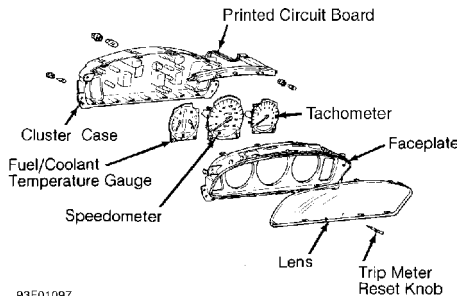

Fig. 46: Instrument Cluster Components (Diamante: W/ Tach Shown; W/O Tach Is Similar)

Courtesy of Mitsubishi Motor Sales of America.

INSTRUMENT PANEL

Article Text (p. 23)

1992 Mitsubishi Mirage

For a a a a

Copyright © 1998 Mitchell Repair Information Company, LLC

Monday, April 01, 2002 09:58AM

Removal & Installation (Eclipse)

1) Disconnect negative battery cable. Remove cluster cover. Remove cluster mounting screws. Remove cluster by turning upper part toward front. Disconnect all necessary electrical connectors. Remove instrument cluster.

2) Disconnect speedometer cable at transaxle end. Pull speedometer cable slightly toward vehicle interior. Release adapter by turning left or right, and remove adapter. To install, reverse removal procedure. See Fig. 47.

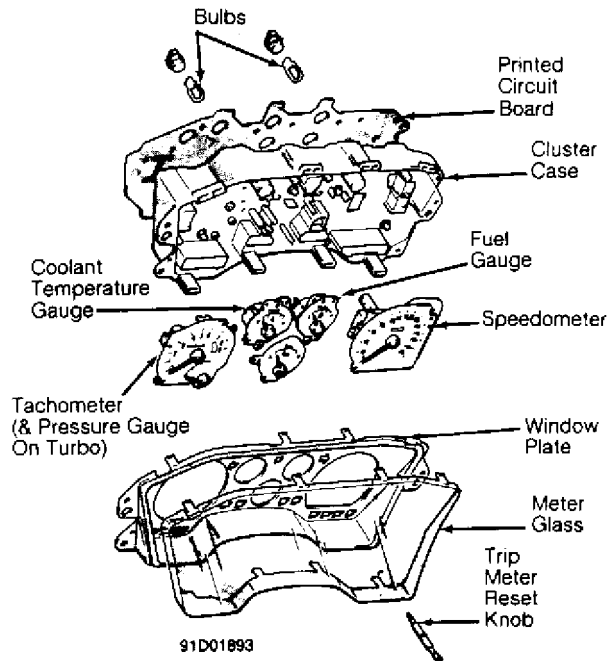

Fig. 47: Instrument Cluster Component ID (Eclipse)
Courtesy of Mitsubishi Motor Sales of America.

Removal & Installation (Colt Vista, Expo/Expo LRV & Summit Wagon)

1) Disconnect negative battery cable. Remove cluster hood. Remove cluster mounting screws. Disconnect necessary electrical connectors.

2) Remove cluster. Remove printed circuit board. Remove cluster glass. Remove gauges as necessary. See Fig. 48. To install, reverse removal procedure.

INSTRUMENT PANEL

Article Text (p. 24)

1992 Mitsubishi Mirage

For a a a a

Copyright © 1998 Mitchell Repair Information Company, LLC

Monday, April 01, 2002 09:58AM

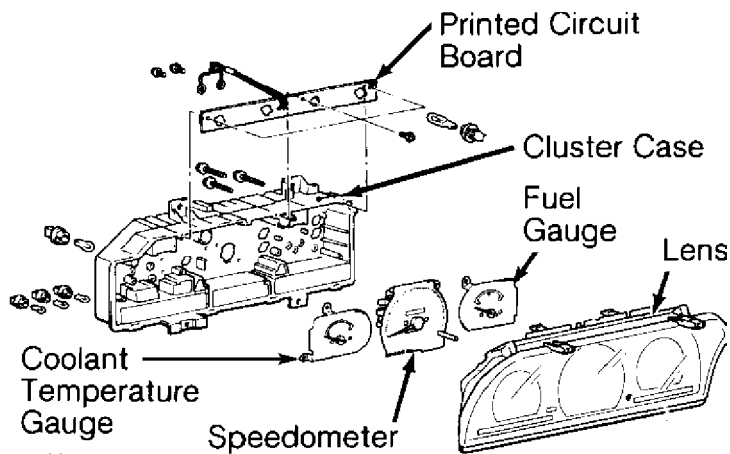

Fig. 48: Instrument Cluster Component ID (Colt Vista, Expo/Expo LRV & Summit Wagon)
Courtesy of Chrysler Motors.

Removal & Installation (Galant)

Disconnect negative battery cable. Remove trip meter reset knob and gauge cluster bezel. See Fig. 49. Remove 4 cluster mounting screws. Remove cluster by turning upper part toward front. Disconnect necessary electrical connectors and speedometer cable adapter. To install, reverse removal procedure.

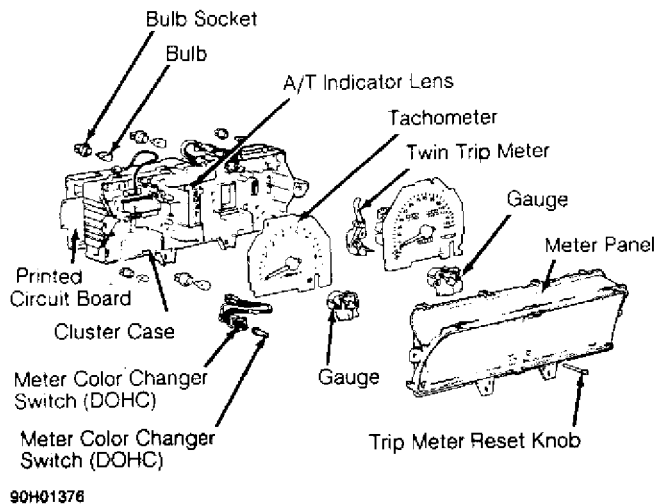

Fig. 49: Instrument Cluster Component ID (Galant)
Courtesy of Mitsubishi Motor Sales of America.

Removal & Installation (Montero)

1) Disconnect negative battery cable. Remove instrument cluster cover plug. Remove cluster cover. Remove screws from instrument cluster.

2) Disconnect speedometer cable from back of instrument cluster. Disconnect all connectors attaching cluster. Remove cluster.

INSTRUMENT PANEL

Article Text (p. 25)

1992 Mitsubishi Mirage

For a a a a

Copyright © 1998 Mitchell Repair Information Company, LLC

Monday, April 01, 2002 09:58AM

To install, reverse removal procedure. See Fig. 50.

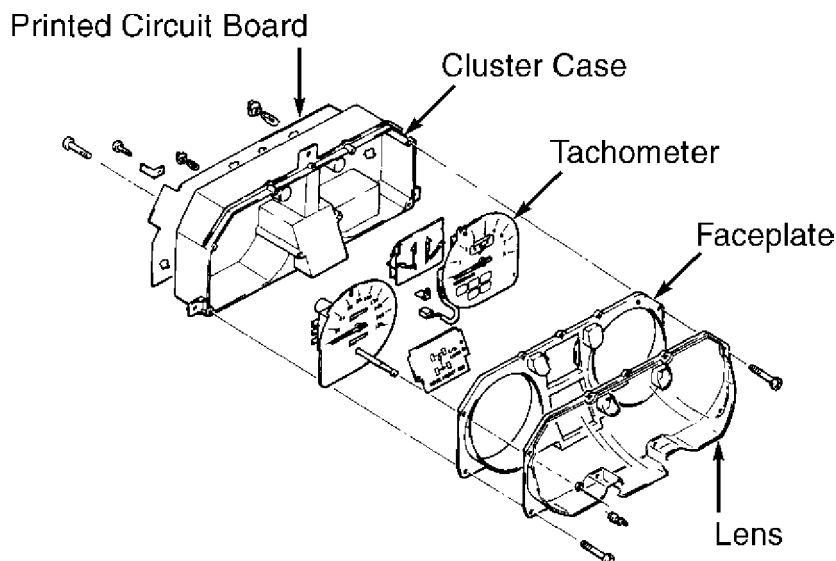

93J01099

Fig. 50: Instrument Cluster Component ID (Montero)
Courtesy of Mitsubishi Motor Sales of America.

Removal & Installation (Pickup & Ram-50)

1) Disconnect negative battery cable. Remove hazard switch. On A/T models, remove hole cover. On M/T models, starter unlock switch will be in place of hole cover. On all models, remove instrument cluster cover.

2) Remove mounting screws from cluster. Remove cluster. Disconnect speedometer cable and electrical connectors from back of cluster. Remove cluster assembly. To install, reverse removal procedure. See Fig. 51 or 52.

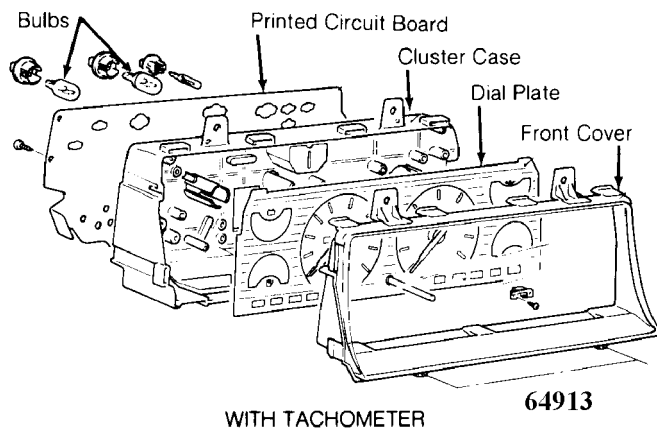

Fig. 51: Instrument Cluster Component ID (Pickup & Ram-50) (W/ Tach)
Courtesy of Mitsubishi Motor Sales of America.

INSTRUMENT PANEL

Article Text (p. 26)

1992 Mitsubishi Mirage

For a a a a

Copyright © 1998 Mitchell Repair Information Company, LLC

Monday, April 01, 2002 09:58AM

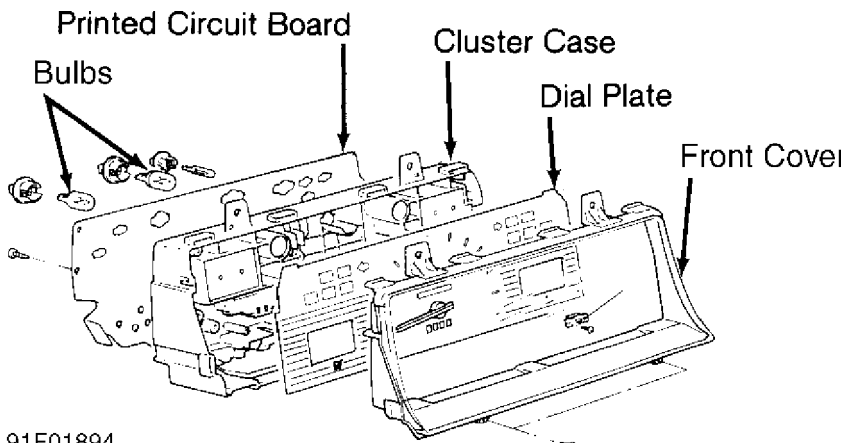

91F01894

Fig. 52: Instrument Cluster Component ID (Pickup & Ram-50) (W/O Tach)
Courtesy of Mitsubishi Motor Sales of America.

Removal & Installation (Stealth & 3000GT)

Disconnect negative battery cable. Remove driver-side knee protector. Remove lower and upper column covers. Remove meter bezel and instrument cluster. Disconnect speedometer cable and connectors from back of cluster. Remove cluster. To install, reverse removal procedure. See Fig. 53.

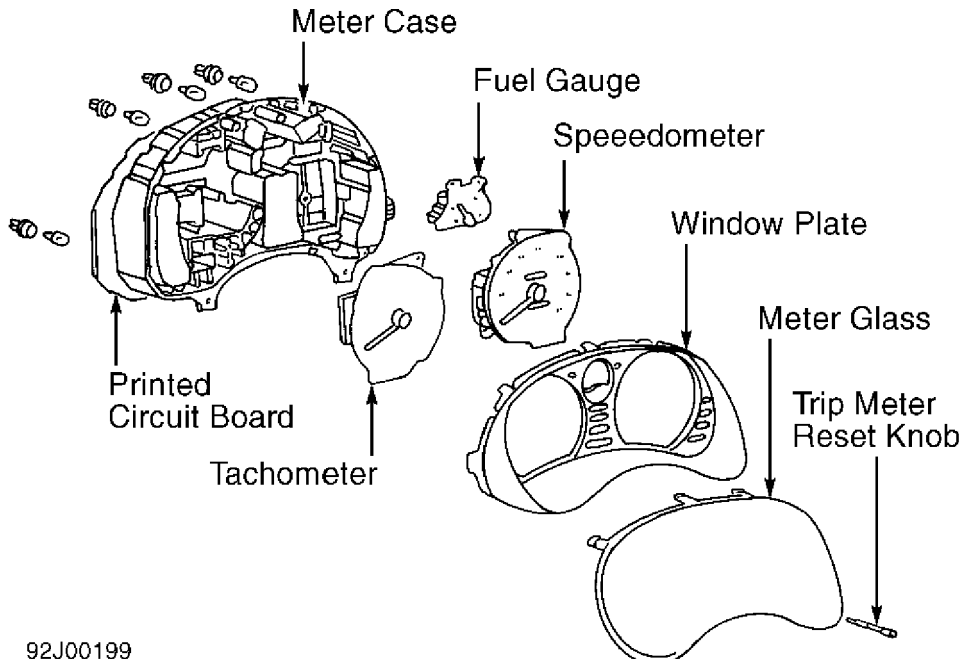

92J00199

Fig. 53: Instrument Cluster Component ID (Stealth & 3000GT)
Courtesy of Mitsubishi Motor Sales of America.

SPEEDOMETER CABLE

NOTE: When routing speedometer cable, DO NOT bend cable sharply. Minimum bending radius is 6" (150 mm). Speedometer cable length varies with transmission type.

INSTRUMENT PANEL

Article Text (p. 27)

1992 Mitsubishi Mirage

For a a a a

Copyright © 1998 Mitchell Repair Information Company, LLC

Monday, April 01, 2002 09:58AM

Removal

Disconnect speedometer cable from transmission or transaxle. Remove instrument cluster from instrument panel. See INSTRUMENT CLUSTER. Disconnect speedometer cable from instrument cluster and/or adapter (if equipped). Remove speedometer cable from firewall grommet.

Installation

1) Install new cable. Insert cable until stopper seats properly in groove on rear of speedometer housing. Pull speedometer cable through firewall grommet until cable marking is visible from engine compartment.

NOTE: An improperly installed cable can cause fluctuating meter, noise or damaged harness inside instrument panel.

2) Install adapter onto speedometer cable (if equipped). Install instrument cluster. See INSTRUMENT CLUSTER. Install cable onto transmission or transaxle. Check for proper operation.

WIRING DIAGRAMS

See appropriate chassis wiring diagram in the WIRING DIAGRAMS Section.

END OF ARTICLE