

STARTER

Article Text

1992 Mitsubishi Mirage

For a a a a

Copyright © 1998 Mitchell Repair Information Company, LLC

Monday, April 01, 2002 10:03AM

ARTICLE BEGINNING

ELECTRICAL

Starters

Diamante, Eclipse, Expo/Expo LRV, Galant, Mirage, Montero, Pickup, Precis, 3000GT

DESCRIPTION

Starter is a conventional 12-volt, 4-pole brush-type motor, with direct or gear reduction drive. The starter-mounted solenoid shifts overrunning clutch and pinion into flywheel when starter is energized.

TROUBLE SHOOTING

NOTE: See the TROUBLE SHOOTING - BASIC PROCEDURES article in the GENERAL TROUBLE SHOOTING section.

NO LOAD TEST

CAUTION: Perform tests in less than 10 seconds to prevent coil damage.

1) Install starter in soft-jawed vise. Connect starter in series with a fully charged 12-volt battery. Connect a 100-amp ammeter and carbon pile rheostat in series with positive battery post and starter motor terminal. See Fig. 1.

2) Install voltmeter across starter motor. Adjust carbon pile rheostat to full resistance. Connect cable from starter motor body to negative battery terminal. Adjust carbon pile rheostat to proper test voltage. See STARTER NO LOAD SPECIFICATIONS table.

3) Note that maximum amperage is within specification and starter rotates smoothly. See STARTER NO LOAD SPECIFICATIONS table.

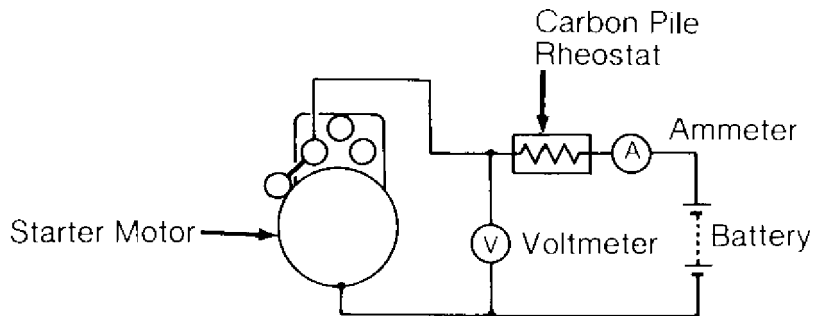

90108769

Fig. 1: Starter No Load Test Connections
Courtesy of Chrysler Motors.

STARTER NO LOAD SPECIFICATIONS

STARTER
Article Text (p. 2)
 1992 Mitsubishi Mirage
 For a a a a

Copyright © 1998 Mitchell Repair Information Company, LLC
 Monday, April 01, 2002 10:03AM

STARTER NO LOAD SPECIFICATIONS

Application	Starter Type (1)	Test Voltage	Maximum Amps @ Minimum RPM
Diamante	GR	11	90 @ 3000
Expo/Expo LRV			
1.8L	DD	11.5	53 @ 6000
1.8L	GR	11	90 @ 3000
2.4L	DD	11.5	60 @ 6600
2.4L	GR	11	90 @ 3000
Eclipse			
1.8L	DD	11.5	60 @ 6600
2.0L	GR	11	90 @ 3000
Galant			
A/T & M/T DOHC	GR	11	90 @ 3000
M/T SOHC	DD	11.5	60 @ 6600
Mirage			
1.5L			
A/T	DD	11.5	60 @ 6600
M/T	DD	11.5	60 @ 6500
1.6L	GR	11	90 @ 3000
Montero	GR	11	90 @ 3000
Pickup			
2.4L A/T & 3.0L	GR	11	90 @ 3000
2.4L M/T	DD	11.5	60 @ 6600
Precis			
A/T	DD	11.5	60 @ 6600
M/T	DD	11.5	60 @ 6500
3000GT	GR	11	90 @ 3000

(1) - The letters DD indicates direct drive and GR indicates gear reduction.

PULL-IN COIL TEST

CAUTION: Perform tests in less than 10 seconds to prevent coil damage.

1) Disconnect field coil wire from terminal "M" at starter solenoid. See Fig. 2. Connect jumper wire between positive battery terminal of 12-volt battery and terminal "S" of solenoid.

2) Connect a second jumper wire from negative battery terminal and touch terminal "M" of starter solenoid. See Fig. 2. If solenoid plunger moves inward, solenoid is good. If not, replace solenoid.

STARTER
Article Text (p. 3)
1992 Mitsubishi Mirage
For a a a a

Copyright © 1998 Mitchell Repair Information Company, LLC
Monday, April 01, 2002 10:03AM

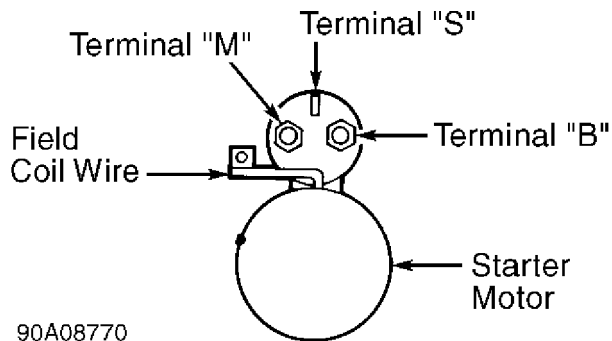

90A08770

Fig. 2: Starter Solenoid Terminal Identification
Courtesy of Chrysler Motors.

HOLD-IN COIL TEST

CAUTION: Perform tests in less than 10 seconds to prevent coil damage.

1) Disconnect field coil wire from terminal "M" at starter solenoid. See Fig. 2. Connect jumper wire between positive battery terminal of 12-volt battery and terminal "S" of starter solenoid.

2) Connect a second jumper wire from negative battery terminal and touch starter case. If solenoid plunger is pulled-in, hold-in coil is good. If not, replace solenoid.

RETURN TEST

CAUTION: Perform tests in less than 10 seconds to prevent coil damage.

1) Disconnect field coil wire from terminal "M" at starter solenoid. See Fig. 2. Connect jumper wire between positive battery terminal of 12-volt battery and terminal "M" of starter solenoid.

2) Connect a second jumper wire from negative battery terminal and touch starter case. Pull pinion outward and release it. Replace solenoid if pinion remains outward.

PINION GAP CHECK

1) Disconnect field coil wire from terminal "M" at starter solenoid. See Fig. 2. Connect jumper wire between positive battery terminal of 12-volt battery and terminal "S" of starter solenoid.

2) Connect a second jumper wire from negative battery terminal and touch terminal "M" of starter solenoid. See Fig. 2. Measure clearance between pinion and stopper. See Fig. 3.

3) Clearance should be within specification. See STARTER SPECIFICATIONS table. Adjust clearance by adding or removing gaskets between solenoid and front housing.

STARTER
Article Text (p. 4)
1992 Mitsubishi Mirage
For a a a a

Copyright © 1998 Mitchell Repair Information Company, LLC
Monday, April 01, 2002 10:03AM

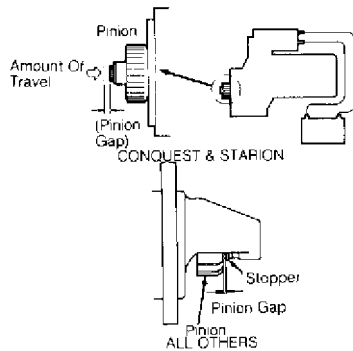

Fig. 3: Measuring Pinion Gap
Courtesy of Mitsubishi Motor Sales of America.

REMOVAL & INSTALLATION

Remove negative battery cable. If necessary, raise vehicle on hoist. Remove starter mounting bolts and starter. To install, reverse removal procedure.

NOTE: On Raider models with A/T, it may be necessary to disconnect transmission oil cooler line for starter removal.

OVERHAUL

Check commutator for out-of-round and proper amount of undercut. Replace or repair armature if not within specification. See STARTER SPECIFICATIONS table. Ensure brushes are not worn beyond wear line (outer line closest to commutator contact surface). Check pinion gap. See PINION GAP CHECK in this article.

DISASSEMBLY

NOTE: Procedures may vary slightly between conventional and reduction gear starters.

1) Loosen nut securing connecting plate-to-magnetic switch "M" terminal. Remove screws securing magnetic switch and remove switch (solenoid) assembly. Remove through bolts and brush cover assembly. Tap yoke assembly loose with wooden mallet. Remove yoke, armature assembly and pinion shift lever.

2) Remove pinion stop ring from end of armature shaft by pushing stop ring to clutch side. Remove snap ring and overrunning clutch assembly from armature shaft.

STARTER
Article Text (p. 5)
 1992 Mitsubishi Mirage
 For a a a a

Copyright © 1998 Mitchell Repair Information Company, LLC
 Monday, April 01, 2002 10:03AM

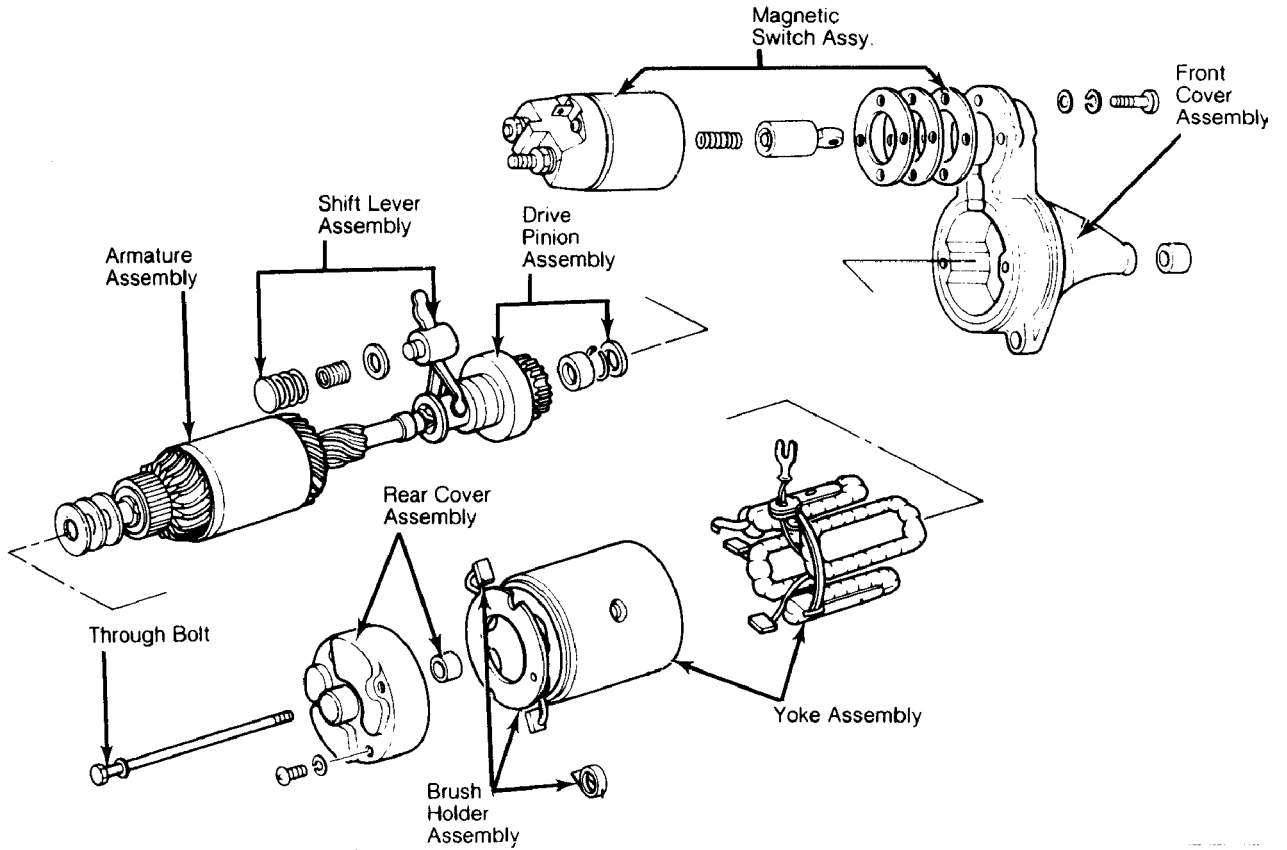

29420
 Fig. 4: Disassembled View of Typical Mitsubishi Starter

CLEANING & INSPECTION

Clean all parts. Do not use grease dissolving solvent on overrunning clutch, armature assembly, solenoid assembly or field coils due to possible damage. Inspect all parts for damage or wear and replace as required.

BENCH TESTS

Brushes & Springs

Check brush spring tension using a spring scale. Check brush contact surface condition and brush length. Check lead clip and wire connections and condition of brush holders. Replace as required. See Brush Spring Tension and Minimum Brush Length Charts.

BRUSH & SPRING SPECIFICATIONS

BRUSH SPRING TENSION

Application	Ozs. (g)
Chrysler Corp. Imports	46-59 (1302-1670)

STARTER
Article Text (p. 6)
1992 Mitsubishi Mirage
For a a a a

Copyright © 1998 Mitchell Repair Information Company, LLC
Monday, April 01, 2002 10:03AM

MINIMUM BRUSH LENGTH (1)

Application	In. (mm)
Chrysler Corp. Imports45 (11.5)

(1) - Minimum brush length should coincide with the brush wear mark.

Armature

Check external condition of armature for scoring or other damage. Measure shaft distortion with dial indicator. Replace armature if shaft distortion exceeds .004" (.10 mm).

Commutator

1) Inspect commutator for roughness, grooves, burns or pitting. Sand lightly with 500 grit sandpaper if necessary. Check commutator for out-of-round and mica insulators undercut to a depth of .020-.031" (.5-.8 mm).

2) If necessary, commutator may be turned less than .04" (1 mm) from original size and mica undercut. Replace if excessively worn.

Field Coil

1) Check field coil continuity by connecting test probe of circuit tester or an ohmmeter to the field coil positive terminal and brush holder. If circuit is open, replace field coil.

2) Check for grounding of field coils by placing one probe of circuit tester on starter housing and other probe to field coil positive terminal. If little or no resistance, field coil is grounded and must be replaced.

Overrunning Clutch Assembly

1) Inspect pinion assembly and sleeve. Sleeve should slide freely on armature shaft and spline. If damage or resistance is noted, replace assembly.

2) Check pinion and flywheel teeth for excessive rubbing or damaged teeth. Replace as required.

Pinion Gear Clearance

The clearance between the pinion gear and pinion stopper collar should be .02-.08" (.51-2.03 mm) on Mitsubishi starters, when solenoid is engaged. Adjust as necessary by changing shims between solenoid and starter yoke.

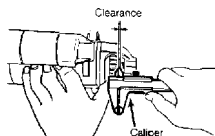

29418

Fig. 5: Measuring Pinion Gear-to-Pinion Stopper Clearance

STARTER

Article Text (p. 7)

1992 Mitsubishi Mirage

For a a a a

Copyright © 1998 Mitchell Repair Information Company, LLC

Monday, April 01, 2002 10:03AM

Pinion Case Bearing

Inspect bearing for wear and check side play. If clearance exceeds .008" (.2 mm), replace bearing. New bearing clearance should be .002-.004" (.05-.10 mm) for Mitsubishi starters.

NOTE: Ensure that bearing is installed so that end of bearing is flush with gear case end.

REASSEMBLY

To reassemble, reverse disassembly procedure. Fill gear case on reduction gear models with grease. Lightly oil pinion and all bearing surfaces.

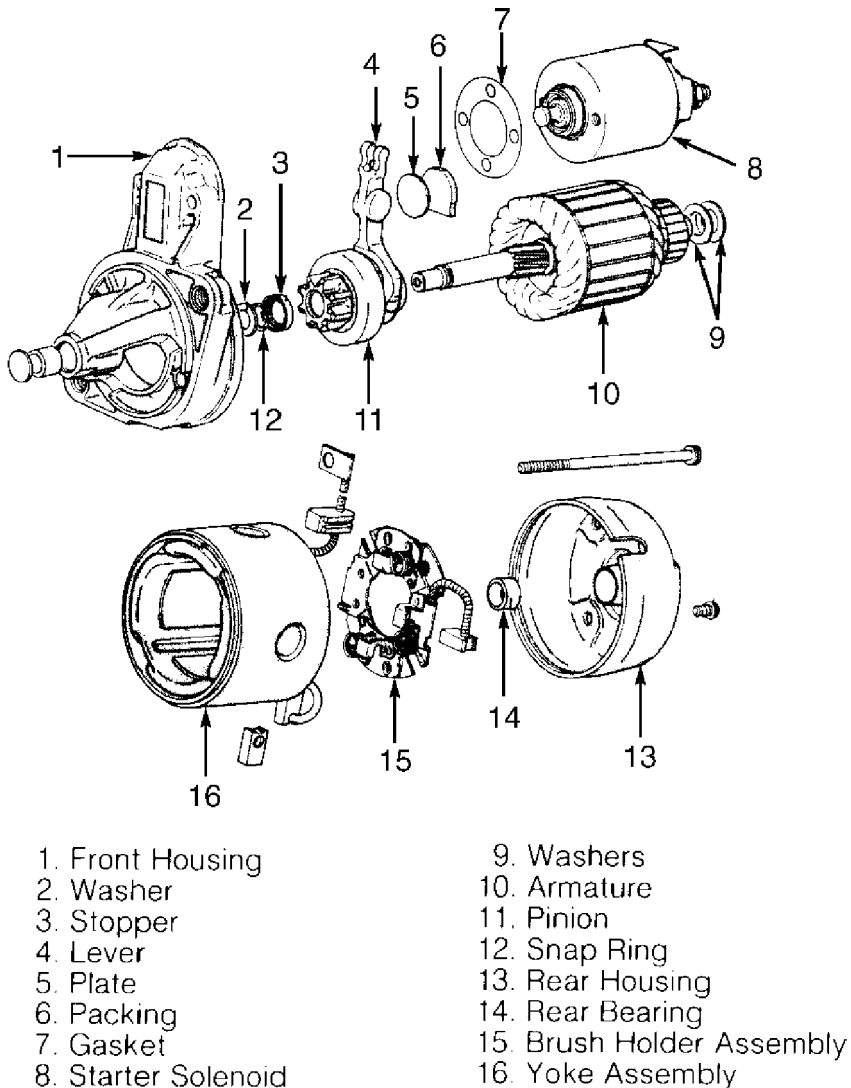

90E08772
Fig. 6: Exploded View of Direct Drive Starter
Courtesy of Mitsubishi Motor Sales of America.

STARTER

Article Text (p. 8)

1992 Mitsubishi Mirage

For a a a a

Copyright © 1998 Mitchell Repair Information Company, LLC
Monday, April 01, 2002 10:03AM

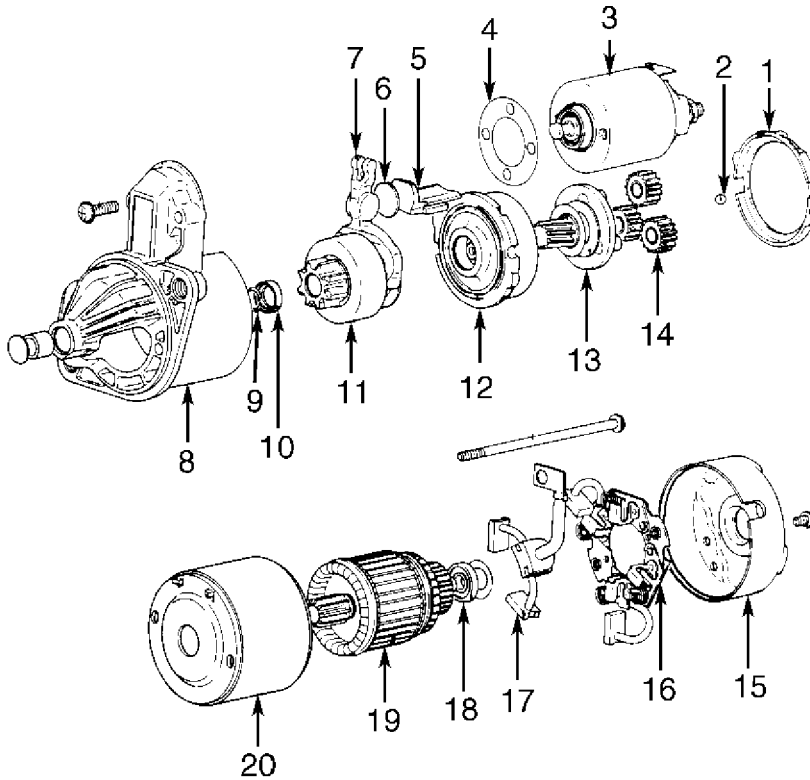

- | | |
|---------------------|---------------------------|
| 1. Packing | 11. Pinion |
| 2. Ball | 12. Internal Gear |
| 3. Starter Solenoid | 13. Planetary Gear Holder |
| 4. Gasket | 14. Planetary Gear |
| 5. Packing | 15. Rear Housing |
| 6. Plate | 16. Brush Holder |
| 7. Lever | 17. Brush |
| 8. Front Housing | 18. Rear Bearing |
| 9. Snap Ring | 19. Armature |
| 10. Stopper | 20. Yoke Assembly |

90108774

Fig. 7: Exploded View of Gear Reduction Starter
Courtesy of Chrysler Motors.

STARTER SPECIFICATIONS

STARTER SPECIFICATIONS

Application	In. (mm)
Commutator Maximum Runout (1)	.004 (.10)
Commutator Minimum Diameter (1)	
Diamante	1.118 (28.40)
Eclipse & Expo/Expo LRV	
1.8L	1.220 (30.99)
2.0L	1.118 (28.40)
Galant	
DOHC & SOHC A/T	1.118 (28.40)

STARTER
Article Text (p. 9)
1992 Mitsubishi Mirage
For a a a a

Copyright © 1998 Mitchell Repair Information Company, LLC
Monday, April 01, 2002 10:03AM

SOHC M/T	1.220	(30.99)
Mirage		
1.5L	1.220	(30.99)
1.6L	1.118	(28.40)
Montero	1.134	(28.80)
Pickup		
2.4L A/T & 3.0L	1.134	(28.80)
2.4L M/T	1.236	(31.39)
3000GT	1.118	(28.40)
Commutator Undercut Depth (1)020	(.51)
Pinion Gap	020-.079	(.51-2.01)

(1) - Information not available on Precis models.

END OF ARTICLE