

---

# CLUTCH

## CONTENTS

<b>1. SPECIFICATIONS</b> .....	<b>21A-1-1</b>
<b>SERVICE SPECIFICATIONS</b> .....	<b>21A-1-1</b>
<b>TORQUE SPECIFICATIONS</b> .....	<b>21A-1-1</b>
<b>LUBRICANTS</b> .....	<b>21A-1-1</b>
<b>2. SPECIAL TOOLS</b> .....	<b>21A-2-1</b>
<b>3. CLUTCH</b> .....	<b>21A-3-1</b>
<b>4. CLUTCH RELEASE CYLINDER</b> .....	<b>21A-4-1</b>
<b>5. CLUTCH DAMPER</b> .....	<b>21A-5-1</b>

## 1. SPECIFICATIONS

### SERVICE SPECIFICATIONS

mm (in.)

Limit

**Clutch disc**

Rivet sink ..... 0.3 (0.01)

**Clutch cover assembly**

Diaphragm spring end height difference ..... 0.5 (0.02)

### TORQUE SPECIFICATIONS

	Nm	Torque kgm	ft.lbs.
Clutch cover bolt .....	15 – 22	1.5 – 2.2	11 – 15
Release cylinder attaching bolt .....	15 – 22	1.5 – 2.2	11 – 15
Transmission attaching bolt .....	43 – 55	4.3 – 5.5	32 – 39
Release cylinder union bolt .....	2.0 – 5.0	0.2 – 0.5	1.5 – 3.6
(Except W5MG1, W6MG1)			
Release cylinder union bolt (W5MG1, W6MG1) .....	23	2.3	17
Release cylinder bleeder plug .....	9 – 13	0.9 – 1.3	6.6 – 9.4
Release fork fulcrum .....	30 – 42	3.0 – 4.2	21.7 – 30.3
Clutch damper bracket bolt .....	9.0	0.9	6.5
Clutch damper bolt .....	19	1.9	14
Clutch oil tube flare nut .....	15	1.5	11
Clutch oil line bracket bolt .....	19	1.9	14
3-way connector mounting bolt .....	19	1.9	14
Clutch damper air breather .....	9.0	0.9	6.5

### LUBRICANTS

	Specified lubricants	Quantity
Clutch release fork shaft .....	MITSUBISHI genuine grease .....	As required
bearing	Part No. 0101011 or equivalent	
Clutch release bearing inside .....	MITSUBISHI genuine grease .....	As required
	Part No. 0101011 or equivalent	
Clutch disc spline .....	MITSUBISHI genuine grease .....	As required
	Part No. 0101011 or equivalent	
Clevis pin .....	MITSUBISHI genuine grease .....	As required
	Part No. 0101011 or equivalent	
Release fork fulcrum .....	MITSUBISHI genuine grease .....	As required
	Part No. 0101011 or equivalent	
Clutch release bearing to .....	MITSUBISHI genuine grease .....	As required
release fork contact surface	Part No. 0101011 or equivalent	
Release cylinder I.D. ....	Brake fluid SAE J1703 (DOT3) .....	As required
Clutch damper O-ring .....	Brake fluid SAE J1703 (DOT3) .....	As required

**2. SPECIAL TOOLS**

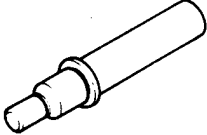
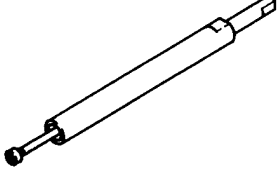
Tool	Number	Name	Use
 A cylindrical tool with a wider, flanged end and a narrower, tapered end.	MD998126	Clutch disc center guide	Aligning clutch disc center hole
 A long, thin, cylindrical tool with a small, rounded tip and a slightly wider section near the other end.	MD998807	Lock pin remover	Removal of spring pin

### 3. CLUTCH

#### CABLE CONTROL TYPE

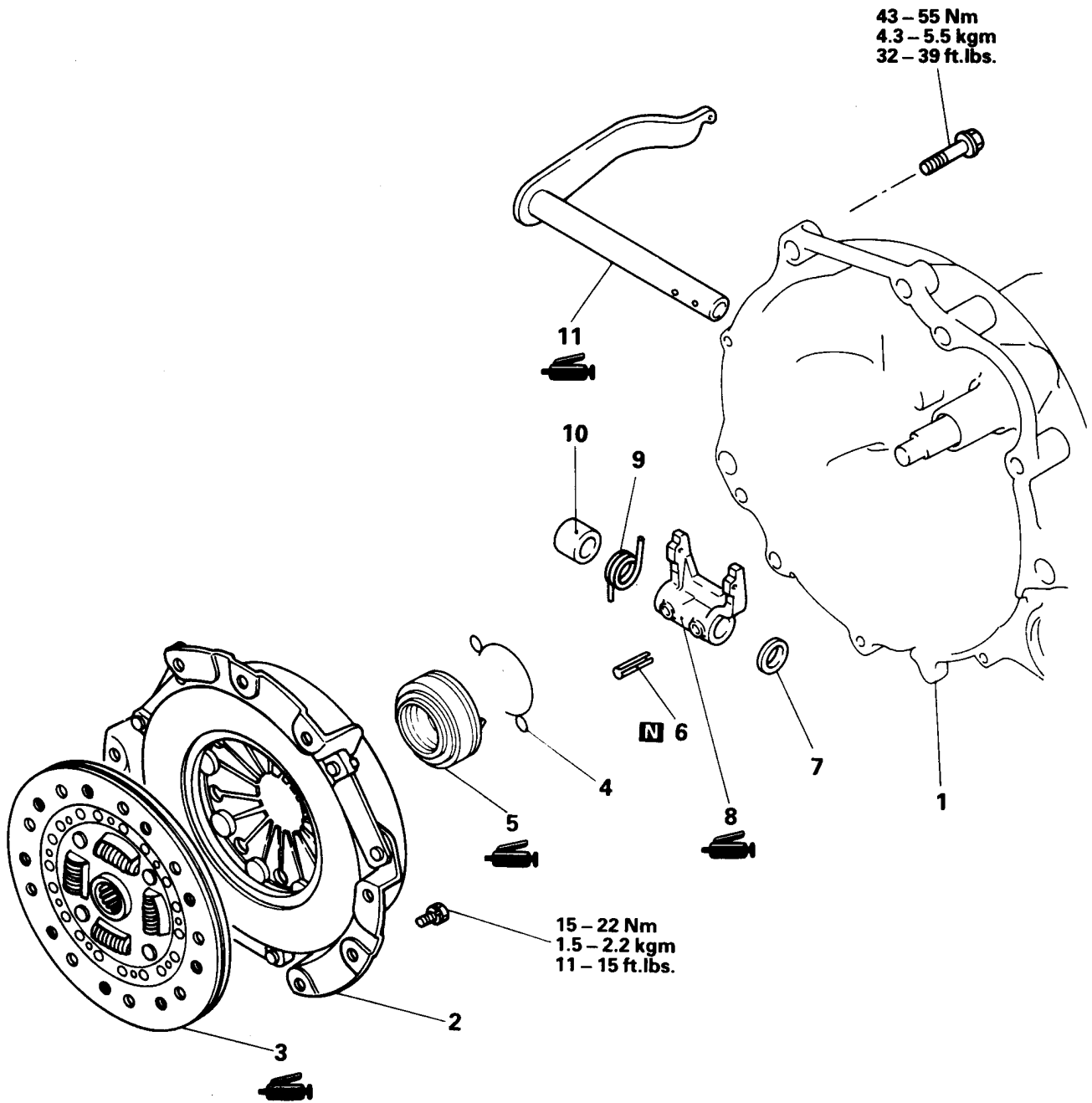

#### Removal steps

- F** 1. Transmission assembly
- E** 2. Clutch cover assembly
- D** 3. Clutch disc
- C** 4. Return clip
- B** 5. Clutch release bearing
- A** **C** 6. Spring pin
- B** 7. Packing
- B** 8. Release fork
- B** 9. Return spring
- 10. Packing
- A** 11. Release fork shaft

HYDRAULIC CONTROL TYPE

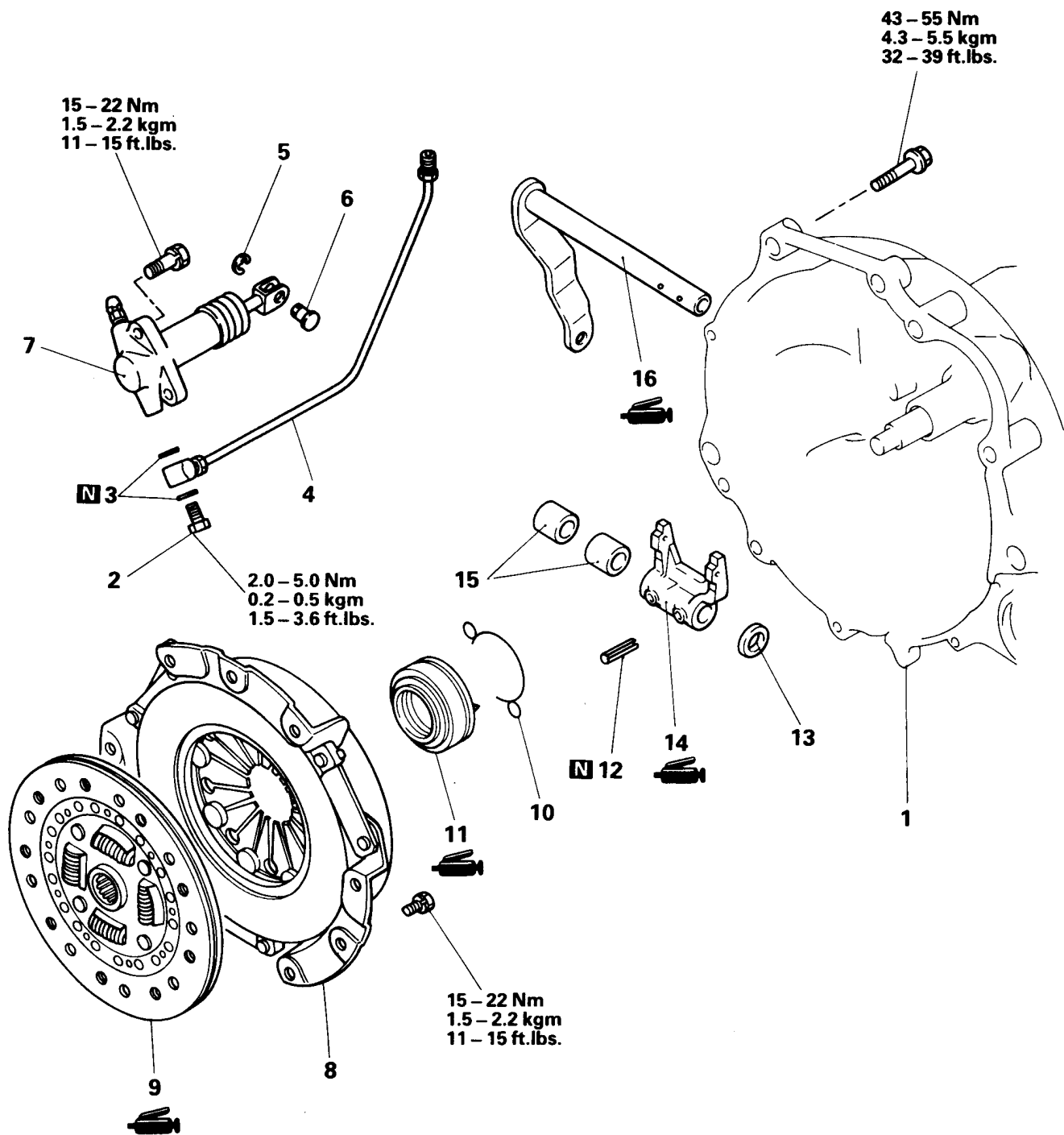

Removal steps

- F** 1. Transmission assembly
- 2. Union bolt
- 3. Gasket
- 4. Clutch oil tube
- 5. Snap pin
- 6. Clevis pin
- 7. Clutch release cylinder assembly
- 8. Clutch cover assembly

- E** 9. Clutch disc
- 10. Return clip
- D** **C** 11. Clutch release bearing
- A** **C** 12. Spring pin
- 13. Packing
- B** 14. Release fork
- 15. Packing
- A** 16. Release fork shaft

HYDRAULIC CONTROL TYPE

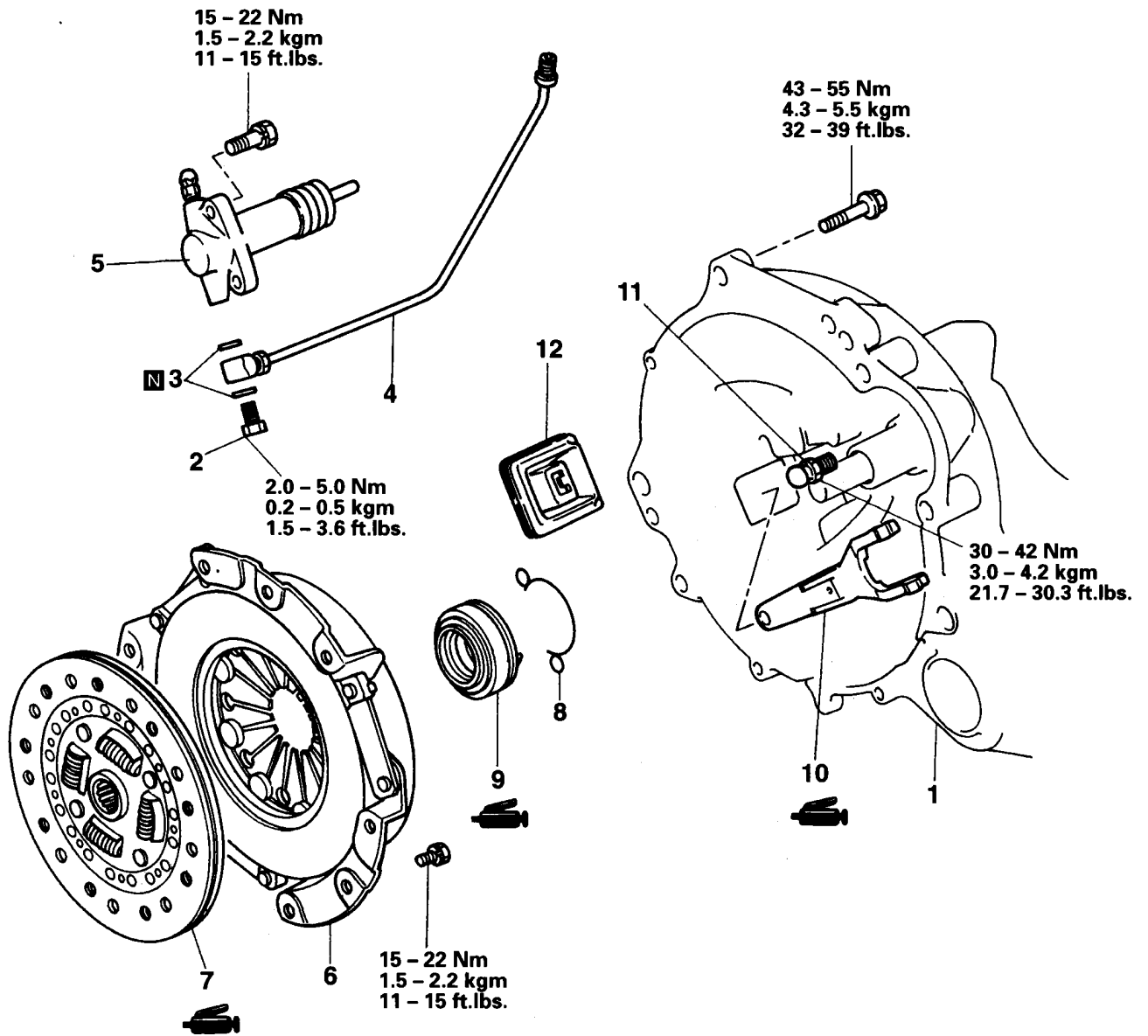

**Removal steps**

- Ⓕ 1. Transmission assembly
- 2. Union bolt
- 3. Gasket
- 4. Clutch oil tube
- 5. Clutch release cylinder assembly
- 6. Clutch cover assembly
- Ⓖ 7. Clutch disc
- 8. Return clip
- Ⓓ 9. Clutch release bearing
- Ⓑ Ⓔ 10. Release fork
- 11. Fulcrum
- 12. Release fork boot

HYDRAULIC CONTROL TYPE

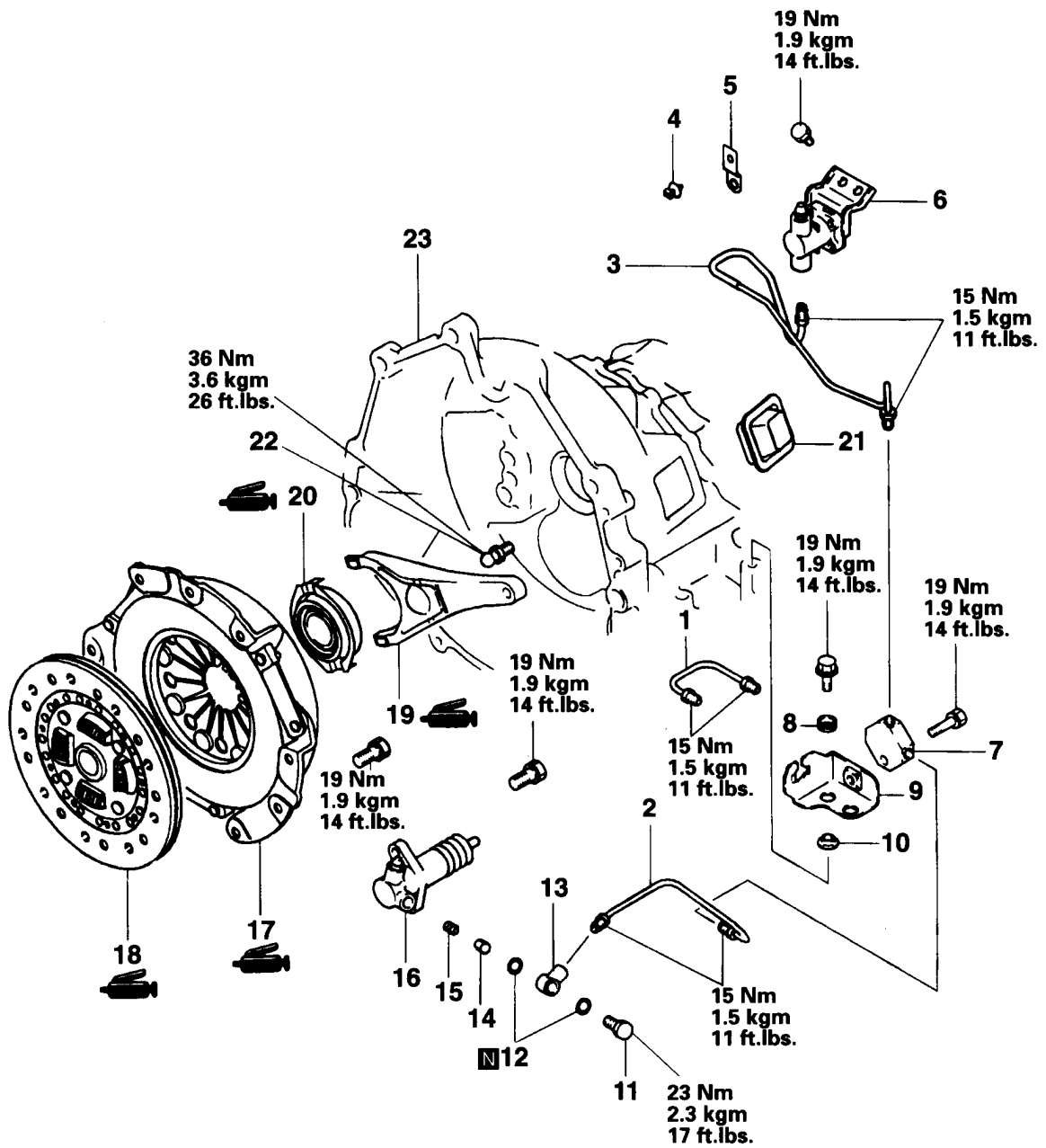

**Removal steps**

- |                            |                             |
|----------------------------|-----------------------------|
| 1. Clutch oil tube (A)     | 13. Union                   |
| 2. Clutch oil tube         | 14. Valve plate             |
| 3. Clutch damper oil tube  | 15. Valve plate spring      |
| 4. Clip                    | 16. Clutch release cylinder |
| 5. Bracket                 | 17. Clutch cover            |
| 6. Clutch damper           | 18. Clutch disc             |
| 7. 3-way connector         | 19. Release fork            |
| 8. Insulator               | 20. Clutch release bearing  |
| 9. Clutch oil line bracket | 21. Release fork boot       |
| 10. Washer                 | 22. Fulcrum                 |
| 11. Union bolt             | 23. Transmission            |
| 12. Gasket                 |                             |

E  
 E  
 G  
 D

Intentionally blank

**Caution**

- When servicing clutch assemblies or components, do NOT create dust by sanding or by cleaning clutch parts with a dry brush or with compressed air. (A water dampened cloth should be used). The clutch disc contains "Asbestos Fibers" which can become airborne if dust is created during service operations. Breathing dust containing "Asbestos Fibers" may cause serious bodily harm.

**NOTE**

Non-asbestos clutch disc has been used on vehicles for EC from the 1988 model.

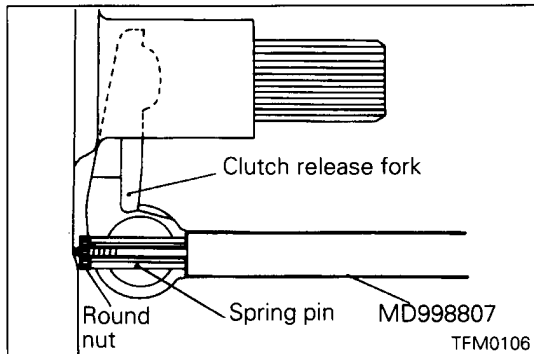
**SERVICE POINTS OF REMOVAL****Ⓐ REMOVAL OF SPRING PIN**

- (1) Insert the special tool in the spring pin, and attach the round nut to the end of the tool.

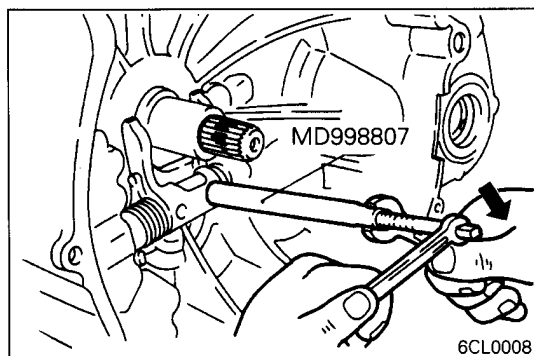

- (2) While holding the shaft of the special tool, rotate the sleeve to force out the spring pin.

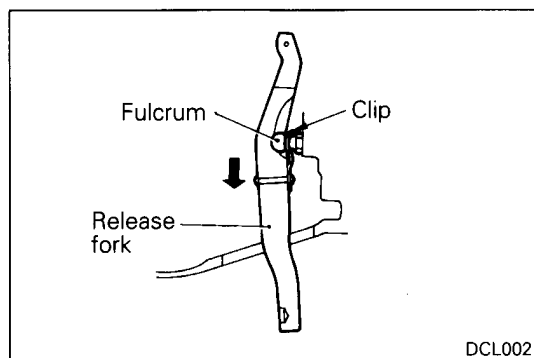
**Ⓑ REMOVAL OF RELEASE FORK**

- (1) Slide release fork in direction of arrow and disengage fulcrum from clip to remove release fork. Be careful not to cause damage to clip by pushing release fork in the direction other than that of arrow and removing it with force.

**INSPECTION****CLUTCH COVER ASSEMBLY**

- (1) Check the diaphragm spring end for wear and uneven height. Replace if wear is evident or height difference exceeds the limit.

**Limit: Max. 0.5 mm (0.02 in.)**

- (2) Check the pressure plate surface for wear, cracks and seizure.
- (3) Check the strap plate rivets for looseness and replace the clutch cover assembly if loose.

**CLUTCH DISC**

- (1) Check the facing for loose rivets, uneven contact, deterioration due to seizure, adhesion of oil or grease, and replace the clutch disc if defective.
- (2) Measure the rivet sink and replace the clutch disc if it is out of specification.

**Limit: Min. 0.3 mm (0.012 in.)**

- (3) Check for torsion spring play and damage and if defective, replace the clutch disc.
- (4) Combine the clutch disc with the input shaft and check sliding condition and play in the rotating direction. If it does not slide smoothly or the play is excessive, check after cleaning and reassembling. If the play is excessive, replace the clutch disc and/or the input shaft.

**CLUTCH RELEASE BEARING****Caution**

- **Release bearing is packed with grease. Therefore, do not wash it in cleaning solvent or the like.**

- (1) Check bearing for seizure, damage, noise, or improper rotation. Check also diaphragm spring contact surface for wear.
- (2) Replace bearing if its release fork contact surface is abnormally worn.

**SERVICE POINTS OF INSTALLATION****Caution**

- **When clutch is installed, apply grease to each greasing part but do not grease it more than necessary. Application of excessive grease will cause clutch to slip or judder.**

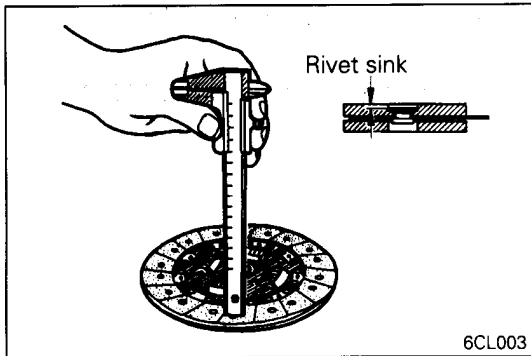

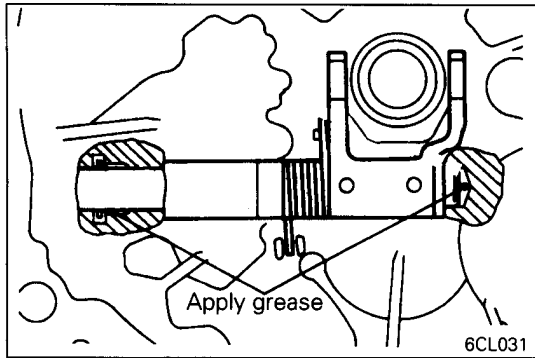

- A APPLICATION OF GREASE TO RELEASE FORK SHAFT**  
**Specified grease:**  
**MITSUBISHI genuine grease Part No. 0101011 or equivalent**

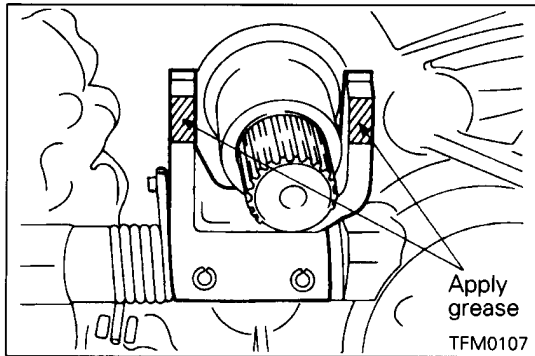

- B APPLICATION OF GREASE TO RELEASE FORK**  
**Specified grease:**  
**Mitsubishi genuine grease Part No. 0101011 or equivalent**

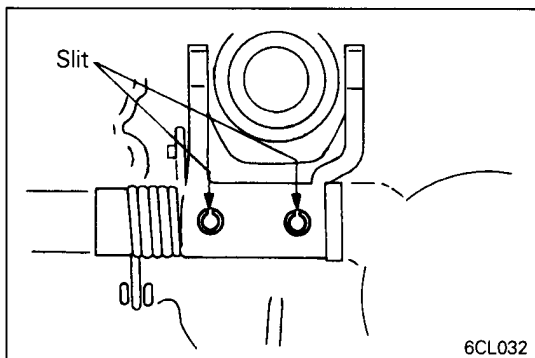

- C INSTALLATION OF SPRING PIN**  
 (1) Drive the spring pin with its slit located as shown in the illustration.  
**Caution**  
 • Do not reuse the spring pins.

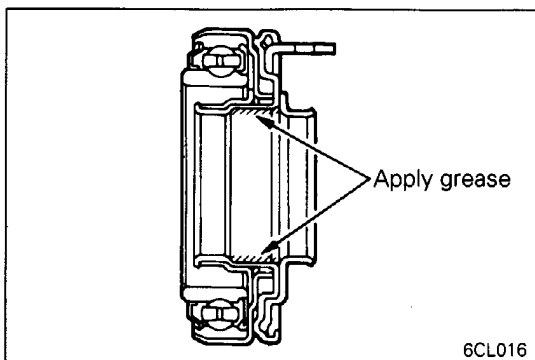

- D APPLICATION OF GREASE TO CLUTCH RELEASE BEARING**  
**Specified grease:**  
**Mitsubishi genuine grease Part No. 0101011 or equivalent**  
**Caution**  
 • Do not apply grease to the resin bearing.

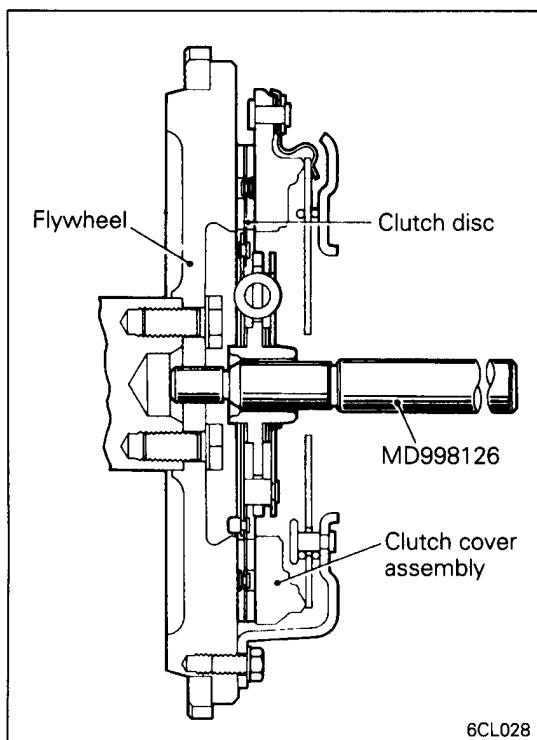
**E INSTALLATION OF CLUTCH DISC**

- (1) Apply specified grease to clutch disc splines and squeeze it in place with a brush.

**Specified grease:**

**Mitsubishi genuine grease Part No. 0101011 or equivalent**

- (2) Use special tool to position clutch disc on flywheel.

**F APPLICATION OF GREASE TO TRANSMISSION INPUT SHAFT SPLINES**

- (1) Apply specified grease to input shaft splines and squeeze it in place with a brush.

**Specified grease:**

**Mitsubishi genuine grease Part No. 0101011 or equivalent**

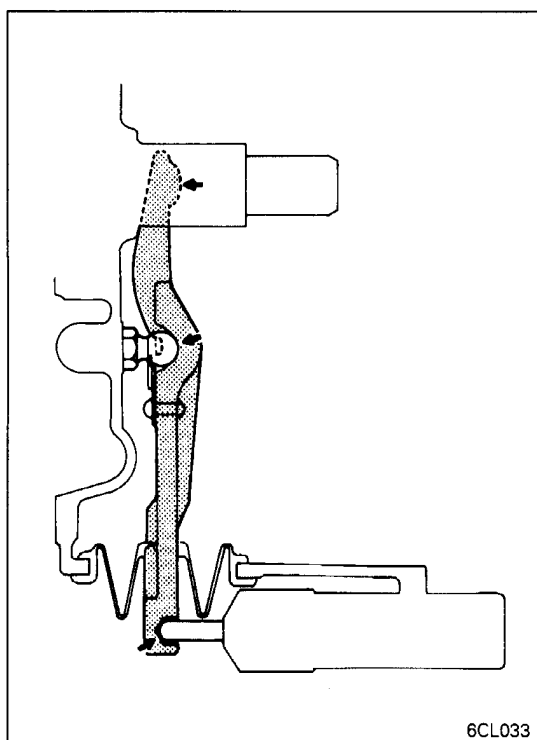
**G APPLICATION OF GREASE TO RELEASE FORK****Specified grease:**

**Mitsubishi genuine grease Part No. 0101011 or equivalent**

4. CLUTCH RELEASE CYLINDER

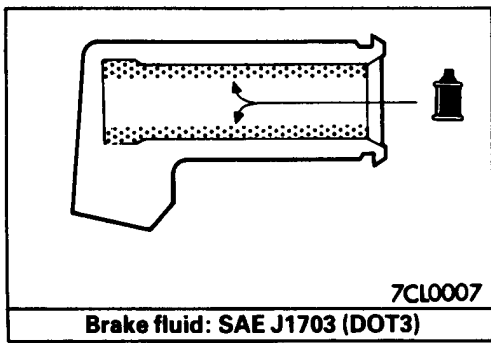

Brake fluid: SAE J1703 (DOT3)

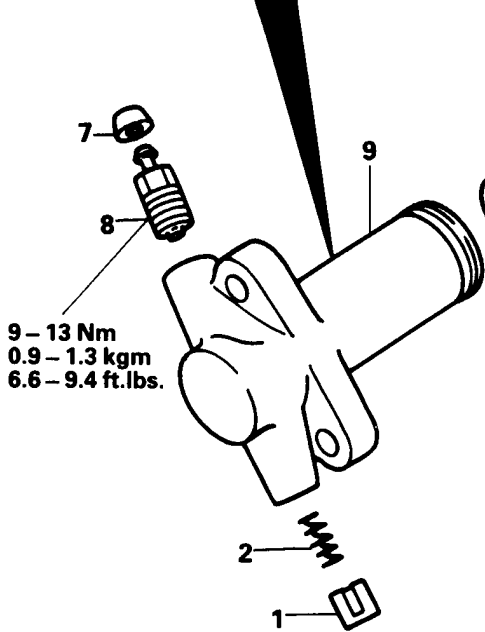

9 – 13 Nm  
0.9 – 1.3 kgm  
6.6 – 9.4 ft.lbs.

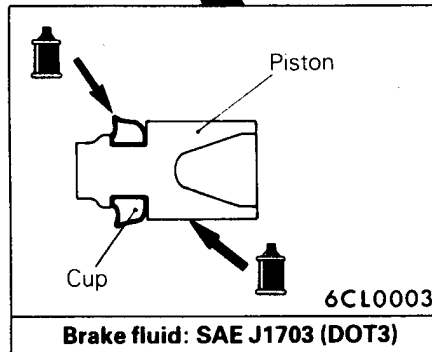
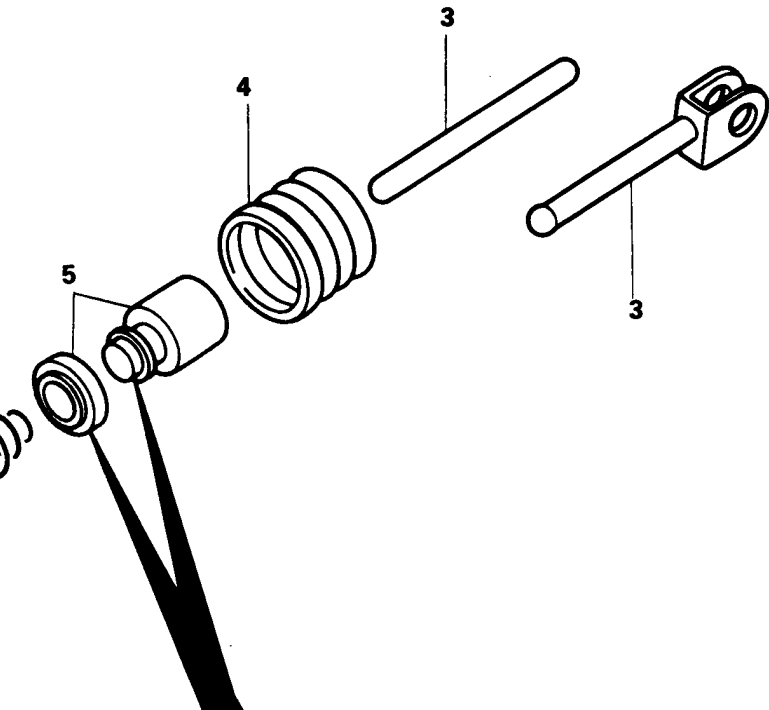

Brake fluid: SAE J1703 (DOT3)

Disassembly steps

1. Valve plate
2. Spring
3. Push rod
4. Boot
5. Piston and cup
6. Conical spring
7. Cap
8. Bleeder plug
9. Release cylinder



6CL034

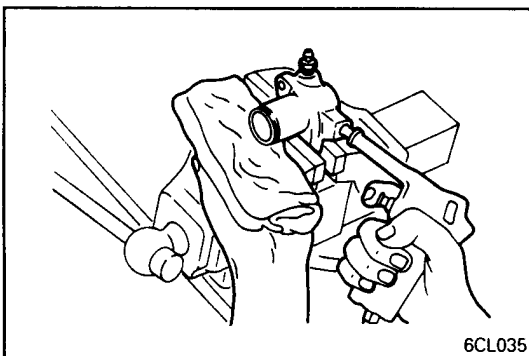

6CL035

SERVICE POINT OF DISASSEMBLY

Ⓐ REMOVAL OF PISTON AND CUP

- (1) Cover with rags to prevent the piston from popping out and remove the piston from the release cylinder using compressed air.

Caution

- Apply compressed air slowly to prevent brake fluid from splashing.

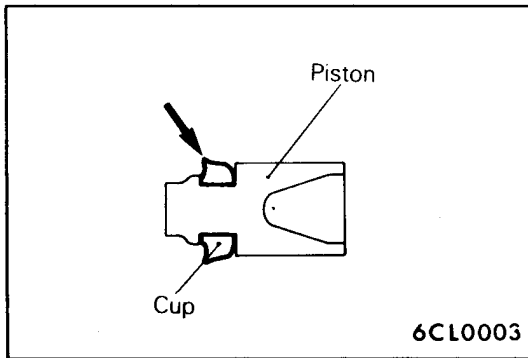
**INSPECTION**

- Check the inside of the release cylinder for scratches and uneven wear.
- Check the piston cup. If its outside circumference is damaged or has deteriorated, or if its lip indicated in the illustration is excessively worn, replace the piston cup.

### 5. CLUTCH DAMPER

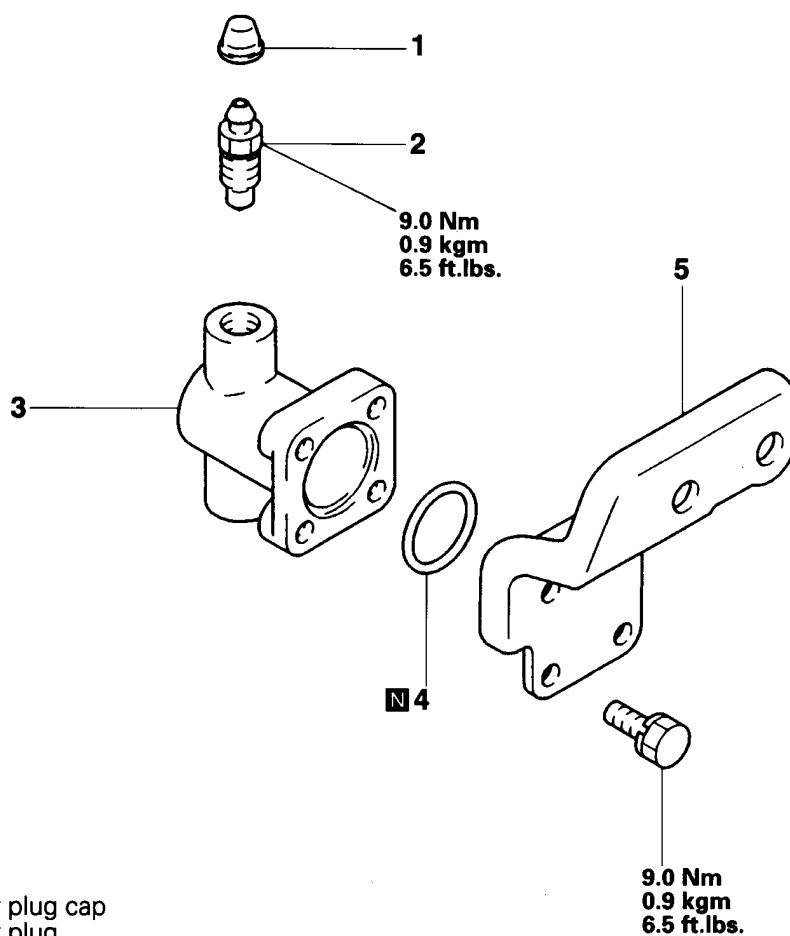

**Disassembly steps**

1. Breather plug cap
2. Breather plug
3. Clutch damper
- A 4. O-ring
5. Clutch damper bracket

TFM0392

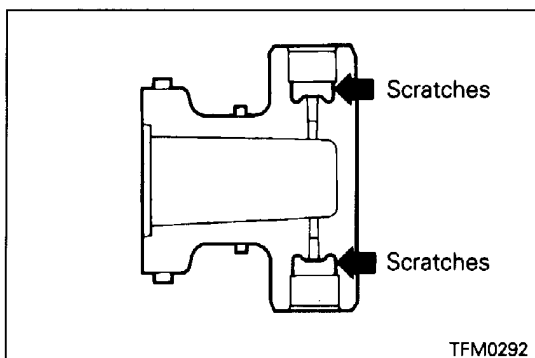

**INSPECTION**

**Clutch damper**

- (1) Check that there are no scratches at the positions shown in the illustration.
- (2) Clean the inside of the clutch damper thoroughly and make sure that there is no foreign materials left in the damper.

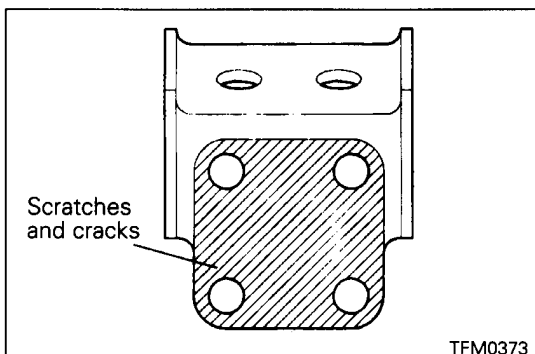

**Clutch damper bracket**

- (1) Check that there are no scratches and cracks at the position shown in the illustration.

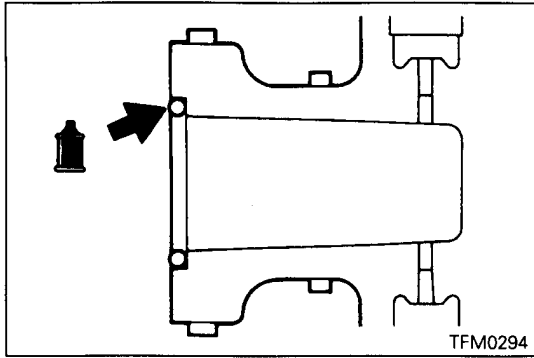
**SERVICE POINT OF REASSEMBLY****A O-RING INSTALLATION**

- (1) Apply specified brake fluid to the O-ring and install it in the clutch damper as shown in the illustration.

**Specified brake fluid:****Brake fluid SAE J1703 (DOT3)**