

MITSUBISHI

FRONT WHEEL DRIVE

MANUAL TRANSMISSION

WORKSHOP MANUAL

FOREWORD

This Workshop Manual contains procedures for removal, disassembly, inspection, adjustment, reassembly and installation, etc. for service mechanics.

All information, illustrations and product descriptions contained in this manual are current as at the time of publication. We, however, reserve the right to make changes at any time without prior notice or obligation.

FILING INSTRUCTION

Please keep these manual pages in the binder No. BN890001.

File these pages according to the signs "Added", "Revised" and "Deleted" on the "List of effective pages" which are interpreted below.

Added: File the pages with this sign additionally in your manual.

Revised. Deleted: Replace the existing pages with the corresponding pages with this sign.

Missing sheets will be supplied upon request.

Clutch **21A**

Manual Transmission **22A**
Model F4M21, F5M21, F5M22,
F5M31, F5M33, W5M31 and W5M33

Manual Transmission **22B**
Model KM182

Manual Transmission **22C**
Model W5MG1, W6MG1

FSMCI

228



INTRODUCTION

EXPLANATION OF MANUAL CONTENTS

Maintenance and Servicing Procedures

- (1) A diagram of the component parts is provided near the front of each section in order to give the reader a better understanding of the installed condition of component parts.
- (2) The numbers provided within the diagram indicate the sequence for maintenance and servicing procedures; the symbol **N** indicates a non-reusable part; the tightening torque is provided where applicable.

- Removal steps:
The part designation number corresponds to the number in the illustration to indicate removal steps.
- Disassembly steps:
The part designation number corresponds to the number in the illustration to indicate disassembly steps.
- Installation steps:
Specified in case installation is impossible in reverse order of removal steps. Omitted if installation is possible in reverse order of removal steps.
- Reassembly steps:
Specified in case reassembly is impossible in reverse order of disassembly steps. Omitted if reassembly is possible in reverse order of disassembly steps.





Classification of Major Maintenance/Service Points

When there are major points relative to maintenance and servicing procedures (such as essential maintenance and service points, maintenance and service standard values, information regarding the use of special tools, etc.), these are arranged together as major maintenance and service points and explained in detail.

- ◁A▷: Indicates that there are essential points for removal or disassembly.
- ◆A◆: Indicates that there are essential points for installation or reassembly.

Symbols for Lubrication, Sealants and Adhesives

Information concerning the locations for lubrication and for application of sealants and adhesives is provided, by using symbols, in the diagram of component parts, or on the page following the component parts page, and explained.

-  Grease
(multipurpose grease unless there is a brand or type specified)
-  Sealant or adhesive
-  Brake fluid, automatic transmission fluid or air conditioner compressor oil
-  Engine oil or gear oil

INTRODUCTION

Indicates the group title.

Indicates the section title.

Indicates the group number.

Indicates the section number.

Indicates the page number.

F4A3, W4A3 - Differential

23B-11-1

11. DIFFERENTIAL DISASSEMBLY AND REASSEMBLY

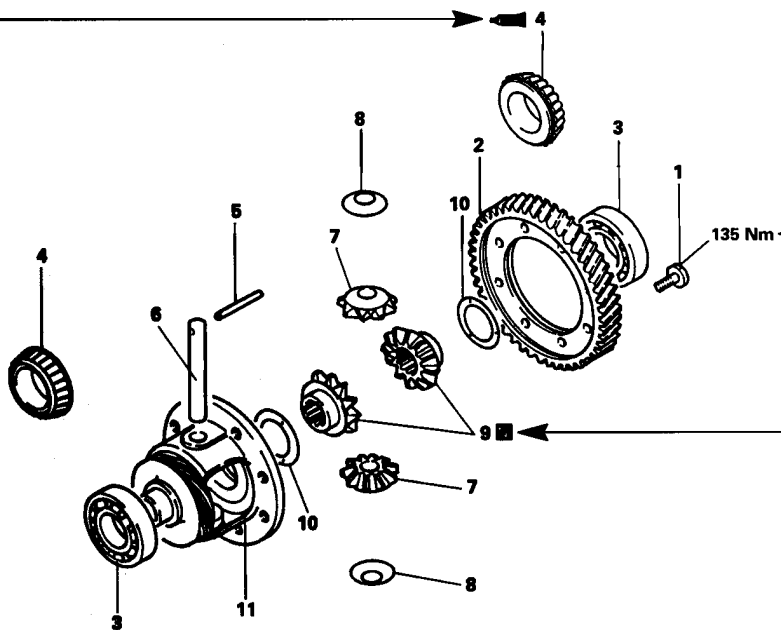

Denotes tightening torque

NOTE:
Torque may also be shown in rectangles in the order of units (Nm, kgm and ft-lbs. from left) as follows:

135 13.5 98

Denotes non-reusable part.

This number corresponds to the number appearing in "Removal steps", "Disassembly steps", "Installation steps" or "Reassembly steps".

Disassembly steps

- 1. Bolt
- 2. Differential drive gear
- 3. Ball bearing (W4A32, W4A33)
- 4. Taper roller bearing (F4A33)
- 5. Lock pin
- 6. Pinion shaft
- 7. Pinion
- 8. Washer
- 9. Side gear
- 10. Spacer
- 11. Differential case

TFA0263

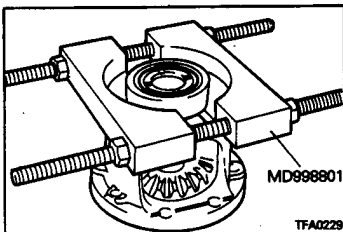

SERVICE POINTS OF DISASSEMBLY

REMOVAL OF BALL BEARING

- (1) Use the special tool to remove the ball bearing.

Operating procedures, cautions, etc. on removal, installation, disassembly and reassembly are described.

© Mitsubishi Motors Corporation Aug. 1991

PWE8000-C

Revised

Issue date

Publication number-Revision code

List of Effective Pages

Page	Revision code	Date	Remarks	Page	Revision code	Date	Remarks
21A-0-1	C	Feb. 1995		22A-3-17 to 22A-3-19		Nov. 1989	
21A-1-1	C	Feb. 1995		22A-3-20 and 22A-3-21	C	Feb. 1995	
21A-2-1		Nov. 1989		22A-3-22 to 22A-3-24		Nov. 1989	
21A-3-1 to 21A-3-3		Nov. 1989		22A-3-25	A	July 1990	
21A-3-3a and 21A-3-3b	C	Feb. 1995		22A-3-26		Nov. 1989	
21A-3-4 and 21A-3-5		Nov. 1989		22A-4-1 to 22A-4-3		Nov. 1989	
21A-3-6 and 21A-3-7	C	Feb. 1995		22A-5-1		Nov. 1989	
21A-4-1 and 21A-4-2		Nov. 1989		22A-5-2		July 1990	
21A-5-1 and 21A-5-2	C	Feb. 1995		22A-5-2a	C	Feb. 1995	
				22A-5-2b	A	July 1990	
22A-0-1	C	Feb. 1995		22A-5-3 to 22A-5-5		Nov. 1989	
22A-0-3 to 22A-0-6		Nov. 1989		22A-5-6 to 22A-5-8	A	July 1990	
22A-0-6a and 22A-0-6b	C	Feb. 1995		22A-5-9 to 22A-5-11	C	Feb. 1995	
22A-0-7 and 22A-0-8		Nov. 1989		22A-5-12	A	July 1990	
22A-0-9	A	July 1990		22A-6-1	C	Feb. 1995	
22A-0-10	A	July 1990		22A-6-2		Nov. 1989	
22A-1-1 and 22A-1-2	A	July 1990		22A-6-3 to 22A-6-6	A	July 1990	
22A-1-3		Nov. 1989		22A-6-7 and 22A-6-8	C	Feb. 1995	
22A-1-4	A	July 1990		22A-6-9	A	July 1990	
22A-1-5 and 22A-1-6	C	Feb. 1995		22A-6-10	C	Feb. 1995	
22A-1-6a to 22A-1-6h	C	Feb. 1995		22A-7-1	C	Feb. 1995	
22A-1-6i and 22A-1-6j	D	Oct. 1995	Added	22A-7-2 and 22A-7-3		Nov. 1989	
22A-1-7 and 22A-1-8	C	Feb. 1995		22A-8-1 and 22A-8-2		Nov. 1989	
22A-1-9	A	July 1990		22A-9-1	C	Feb. 1995	
22A-1-10 to 22A-1-15	C	Feb. 1995		22A-9-2		Nov. 1989	
22A-1-16 to 22A-1-19	A	July 1990		22A-9-3	C	Feb. 1995	
22A-1-20	C	Feb. 1995		22A-10-1 to 22A-10-4	A	July 1990	
22A-2-1 to 22A-2-4		Nov. 1989		22A-11-1 and 22A-11-2		Nov. 1989	
22A-3-1 to 22A-3-3		Nov. 1989		22A-12-1 to 22A-12-3		Nov. 1989	
22A-3-4	C	Feb. 1995		22A-12-4	C	Feb. 1995	
22A-3-5 and 22A-3-6		Nov. 1989		22A-13-1		Nov. 1989	
22A-3-7	C	Feb. 1995		22A-14-1 to 22A-14-3		Nov. 1989	
22A-3-8 and 22A-3-9		Nov. 1989		22A-15-1	A	July 1990	
22A-3-9a to 22A-3-9d	C	Feb. 1995		22A-15-2 to 22A-15-4		Nov. 1989	
22A-3-10	C	Feb. 1995		22A-15-5	A	July 1990	
22A-3-11 to 22A-3-13		Nov. 1989		22A-16-1		Nov. 1989	
22A-3-13a	C	Feb. 1995		22A-17-1 and 22A-17-2		Nov. 1989	
22A-3-13b to 22A-3-13d	A	July 1990		22A-18-1 to 22A-18-3		Nov. 1989	
22A-3-14 and 22A-3-15		Nov. 1989		22A-19-1 and 22A-19-2		Nov. 1989	
22A-3-16	A	July 1990		22A-20-1		Nov. 1989	

Missing sheets will be supplied upon request.

PWEE8902-D

Page	Revision code	Date	Remarks
22B-0-1	A	July 1990	
22B-0-3	A	July 1990	
22B-1-1 to 22B-1-5	A	July 1990	
22B-2-1 to 22B-2-3	A	July 1990	
22B-3-1 to 22B-3-8	A	July 1990	
22B-4-1 to 22B-4-4	A	July 1990	
22B-5-1	A	July 1990	
22B-6-1 to 22B-6-3	A	July 1990	
22B-7-1 and 22B-7-2	A	July 1990	
22B-8-1	A	July 1990	
22B-9-1 and 22B-9-2	A	July 1990	
22C-0-1 to 22C-0-3	C	Feb. 1995	
22C-0-4	C	Feb. 1995	
22C-1-1	D	Oct. 1995	Revised

Page	Revision code	Date	Remarks
22C-1-2 and 22C-1-3	C	Feb. 1995	
22C-2-1	C	Feb. 1995	
22C-2-2 to 22C-2-5	C	Feb. 1995	
22C-3-1 to 22C-3-3	C	Feb. 1995	
22C-3-4 to 22C-3-21	C	Feb. 1995	
22C-4-1 to 22C-4-6	C	Feb. 1995	
22C-5-1 to 22C-5-10	C	Feb. 1995	
22C-6-1	C	Feb. 1995	
22C-7-1	C	Feb. 1995	
22C-8-1 to 22C-8-3	C	Feb. 1995	
22C-9-1 and 22C-9-2	C	Feb. 1995	
22C-10-1 to 22C-10-5	C	Feb. 1995	
22C-11-1 and 22C-11-2	C	Feb. 1995	
22C-12-1	C	Feb. 1995	
22C-13-1	C	Feb. 1995	

Missing sheets will be supplied upon request.

PWEE8902-D

mitsubishi

FRONT WHEEL DRIVE MANUAL TRANSMISSION

WORKSHOP MANUAL

FOREWORD

This Workshop Manual contains procedures for removal, disassembly, inspection, adjustment, reassembly and installation, etc. for service mechanics.

All information, illustrations and product descriptions contained in this manual are current as at the time of publication. We, however, reserve the right to make changes at any time without prior notice or obligation.

FILING INSTRUCTION

Please keep these manual pages in the binder No. BN890001.

File these pages according to the signs "Added", "Revised" and "Deleted" on the "List of effective pages" which are interpreted below.

Added: File the pages with this sign additionally in your manual.

Revised. Deleted: Replace the existing pages with the corresponding pages with this sign.

Missing sheets will be supplied upon request.

Clutch **21A**

Manual Transmission **22A**
Model F4M21, F5M21, F5M22,
F5M31, W5M31 and W5M33

Manual Transmission **22B**
Model KM182

Manual Transmission **22C**
Model W5MG1

Manual Transmission **22D**
Model F5MC1



INTRODUCTION

EXPLANATION OF MANUAL CONTENTS

Maintenance and Servicing Procedures

- (1) A diagram of the component parts is provided near the front of each section in order to give the reader a better understanding of the installed condition of component parts.
- (2) The numbers provided within the diagram indicate the sequence for maintenance and servicing procedures; the symbol **N** indicates a non-reusable part; the tightening torque is provided where applicable.

- Removal steps:
The part designation number corresponds to the number in the illustration to indicate removal steps.
- Disassembly steps:
The part designation number corresponds to the number in the illustration to indicate disassembly steps.
- Installation steps:
Specified in case installation is impossible in reverse order of removal steps. Omitted if installation is possible in reverse order of removal steps.
- Reassembly steps:
Specified in case reassembly is impossible in reverse order of disassembly steps. Omitted if reassembly is possible in reverse order of disassembly steps.





Classification of Major Maintenance/Service Points

When there are major points relative to maintenance and servicing procedures (such as essential maintenance and service points, maintenance and service standard values, information regarding the use of special tools, etc.), these are arranged together as major maintenance and service points and explained in detail.

- ◀A▶: Indicates that there are essential points for removal or disassembly.
▶A▶: Indicates that there are essential points for installation or reassembly.

Symbols for Lubrication, Sealants and Adhesives

Information concerning the locations for lubrication and for application of sealants and adhesives is provided, by using symbols, in the diagram of component parts, or on the page following the component parts page, and explained.

- Grease
(multipurpose grease unless there is a brand or type specified)
- Sealant or adhesive
- Brake fluid, automatic transmission fluid
or air conditioner compressor oil
- Engine oil or gear oil

INTRODUCTION

Indicates the group title.

Indicates the section title.

Indicates the group number.

Indicates the section number.

Indicates the page number.

F4A3, W4A3 – Differential

23B-11-1

11. DIFFERENTIAL

DISASSEMBLY AND REASSEMBLY

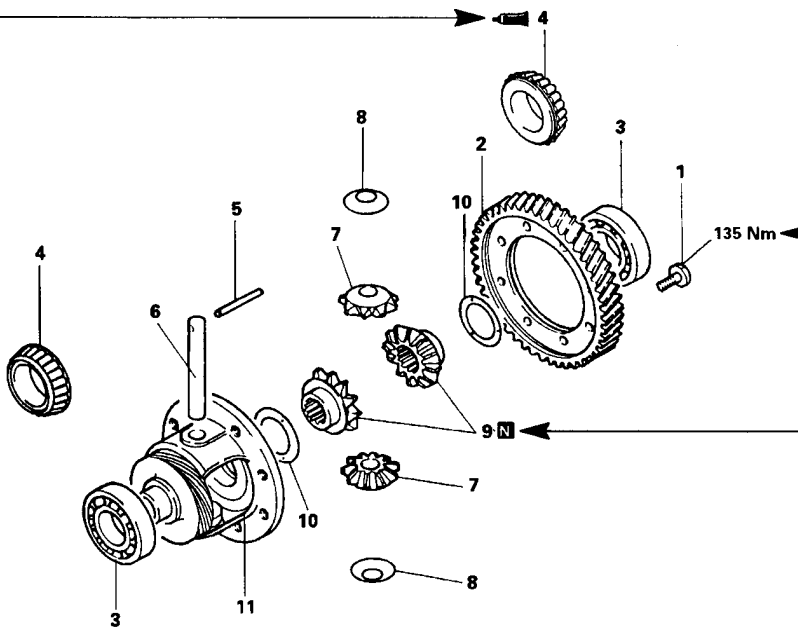

Denotes tightening torque.

Denotes non-reusable part.

This number corresponds to the number appearing in "Removal steps", "Disassembly steps", "Installation steps" or "Reassembly steps".

Disassembly steps

- ⚡E⚡ 1. Bolt
- ⚡A⚡ ⚡D⚡ 2. Differential drive gear
- ⚡B⚡ ⚡C⚡ 3. Ball bearing (W4A32, W4A33)
- ⚡C⚡ ⚡B⚡ 4. Taper roller bearing (F4A33)
- ⚡A⚡ ⚡B⚡ 5. Lock pin
- ⚡A⚡ 6. Pinion shaft
- ⚡A⚡ 7. Pinion
- ⚡A⚡ 8. Washer
- ⚡A⚡ 9. Side gear
- ⚡A⚡ 10. Spacer
- 11. Differential case

TFA0263

SERVICE POINTS OF DISASSEMBLY

⚡A⚡ REMOVAL OF BALL BEARING

- (1) Use the special tool to remove the ball bearing.

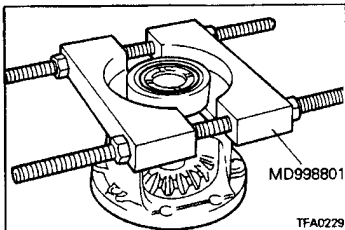

MD998801

TFA0229

Operating procedures, cautions, etc. on removal, installation, disassembly and reassembly are described.

© Mitsubishi Motors Corporation Aug. 1991

PWEE806-C

Revised

Issue date

Publication number-Revision code

List of Effective Pages

Page	Revision code	Date	Remarks	Page	Revision code	Date	Remarks
21A-0-1		Nov. 1989		22A-10-1 to 22A-10-4	A	July 1990	
21A-1-1		Nov. 1989		22A-11-1 and 22A-11-2		Nov. 1989	
21A-2-1		Nov. 1989		22A-12-1 to 22A-11-4		Nov. 1989	
21A-3-1 to 21A-3-7		Nov. 1989		22A-13-1		Nov. 1989	
21A-4-1 and 21A-4-2		Nov. 1989		22A-14-1 to 22A-14-3		Nov. 1989	
22A-0-1	A	July 1990		22A-15-1	A	July 1990	
22A-0-3 to 22A-0-8		Nov. 1989		22A-15-2 to 22A-11-4		Nov. 1989	
22A-0-9	A	July 1990		22A-15-5	A	July 1990	
22A-0-10	A	July 1990		22A-16-1		Nov. 1989	
22A-1-1 and 22A-1-2	A	July 1990		22A-17-1 and 22A-17-2		Nov. 1989	
22A-1-3		Nov. 1990		22A-18-1 to 22A-18-3		Nov. 1989	
22A-1-4 to 22A-1-16	A	July 1990		22A-19-1 and 22A-9-2		Nov. 1989	
22A-1-17 to 22A-1-20	A	July 1990		22A-20-1		Nov. 1989	
22A-2-1 to 22A-2-4		Nov. 1989		22B-0-1	A	July 1990	
22A-3-1 to 22A-3-3		Nov. 1989		22B-0-3	A	July 1990	
22A-3-4	A	July 1990		22B-1-1 to 22B-1-5	A	July 1990	
22A-3-5 and 22A-3-6		Nov. 1989		22B-2-1 to 22B-2-3	A	July 1990	
22A-3-7	A	July 1990		22B-3-1 to 22B-3-8	A	July 1990	
22A-3-8 and 22A-3-9		Nov. 1989		22B-4-1 to 22B-4-4	A	July 1990	
22A-3-10	A	July 1990		22B-5-1	A	July 1990	
22A-3-11 to 22A-3-13		Nov. 1989		22B-6-1 to 22B-6-3	A	July 1990	
22A-3-13a to 22A-3-13d	A	July 1990		22B-7-1 and 22B-7-2	A	July 1990	
22A-3-14 and 22A-3-15		Nov. 1989		22B-8-1	A	July 1990	
22A-3-16	A	July 1990		22B-9-1 and 22B-9-2	A	July 1990	
22A-3-17 to 22A-3-24		Nov. 1989		22C-0-1	B	June 1992	
22A-3-25	A	July 1990		22C-0-3	B	June 1992	
22A-3-26		Nov. 1989		22C-1-1	B	June 1992	
22A-4-1 to 22A-4-3		Nov. 1989		22C-2-1	B	June 1992	
22A-5-1		Nov. 1989		22C-3-1 to 22C-3-3	B	June 1992	
22A-5-2	A	July 1990		22D-0-1	C	May 1994	Added
22A-5-2a and 22A-5-2b	A	July 1990		22D-1-1	C	May 1994	Added
22A-5-3 to 22A-5-5		Nov. 1989		22D-2-1 to 22D-2-3	C	May 1994	Added
22A-5-6 to 22A-5-12	A	July 1990		22D-3-1 to 22D-3-4	C	May 1994	Added
22A-6-1	A	July 1990		22D-4-1 to 22D-4-3	C	May 1994	Added
22A-6-2		Nov. 1989		23B-5-1	C	May 1994	Added
22A-6-3 to 22A-6-10	A	July 1990		23B-6-1	C	May 1994	Added
22A-7-1 to 22A-7-3		Nov. 1989		23B-7-1 to 22D-7-3	C	May 1994	Added
22A-8-1 and 22A-8-2		Nov. 1989					
22A-9-1 to 22A-9-3		Nov. 1989					

Missing sheets will be supplied upon request.

Page	Revision code	Date	Remarks
23B-8-1 to 22D-8-2	C	May 1994	Added
22D-9-1	C	May 1994	Added
22D-10-1 to 22D-10-6	C	May 1994	Added

Page	Revision code	Date	Remarks
22D-11-1 to 22D-11-3	C	May 1994	Added
22D-12-1 to 22D-12-4	C	May 1994	Added
22D-13-1	C	May 1994	Added

Missing sheets will be supplied upon request.

PWEE8902-C